

# KINZE VISION® PLANTER CONTROL SYSTEM DISPLAY

## OPERATOR MANUAL

M0214

Rev. 6/08

This manual is applicable to: KINZE Vision® Planter Control System Display  
Firmware Version: 5.0

Record the serial numbers of your planter control system display and switch console, and the purchase date:

Display Serial Number \_\_\_\_\_

Switch Console Serial Number \_\_\_\_\_

Date Purchased \_\_\_\_\_

### SERIAL NUMBER

The serial number plates are located on the back side of the display. It is suggested that your serial number and purchase date also be recorded above.

The serial number provides important information about your display and may be required to obtain the correct replacement part. Always provide the model number and serial number to your KINZE® Dealer when ordering parts or anytime correspondence is made with KINZE Manufacturing, Inc.

D0129081000



*KINZE®, the KINZE® logo, Twin-Line®, Interplant®, EdgeVac® and KINZE Vision® are trademarks owned by KINZE Manufacturing, Inc.*

*Ag Leader Technology®, Insight™, SeedCommand™, AutoSwath™, DirectCommand™, Smart Report™ and SMS™ are trademarks of Ag Leader Technology, Inc.*

*OmniSTAR® is a trademark of Fugro N.V.*

*Trimble®, AutoSeed™ and AgGPS® are trademarks of Trimble Navigation Limited*

*RAM® is a trademark of National Products Inc.*

*Rawson®, Accu-Rate™ and Accu-Plant™ are trademarks of Rawson Control Systems, Inc.*

*Flexi-Coil® and Flex-Control® are trademarks of CNH Canada Ltd.*

*Adobe®, Acrobat® and Reader® are trademarks of Adobe Systems Incorporated.*

**This page intentionally left blank.**

# TABLE OF CONTENTS

---

TO THE OWNER .....	1-1
WARRANTY .....	1-2
INTRODUCTION .....	2-1
SPECIFICATIONS.....	3-1
<b>SYSTEM OVERVIEW</b>	
<b>General Information</b> .....	<b>4-1</b>
KINZE Vision® System .....	4-1
KINZE® Planter Control System Wiring Diagram .....	4-2
KINZE Vision® Installation Instructions.....	4-3
KINZE Vision® System Power Up.....	4-4
System Navigation Buttons.....	4-6
Run Screen Command Buttons .....	4-7
Run Screen Display Area.....	4-8
Display Items And Area Count.....	4-9
Getting Started.....	4-10
Setup Tips .....	4-11
<b>General Setup</b> .....	<b>4-12</b>
General Setup Overview .....	4-12
On Screen Help .....	4-12
<b>Management Data Setup</b> .....	<b>4-13</b>
Field Operation Data Storage .....	4-13
Grower Setup Screen .....	4-14
<b>Season Setup</b> .....	<b>4-15</b>
Season Setup Screen.....	4-15
<b>Grower Setup</b> .....	<b>4-16</b>
Adding A New Grower.....	4-19
Adding or Editing Grower Personal Information.....	4-17
Importing A Management Setup File .....	4-18
<b>Field Setup</b> .....	<b>4-20</b>
Field Setup Screen .....	4-20
Adding a New Field.....	4-22
Importing/Exporting Boundaries .....	4-23
<b>Operator Setup</b> .....	<b>4-24</b>
Operator Setup Screen .....	4-24
Adding A New Operator .....	4-25
Adding or Editing Operator Personal Information .....	4-26
<b>Field Notes</b> .....	<b>4-27</b>
Field Notes Setup Screen.....	4-27
Creating a New Marker .....	4-28
Editing A Marker Name .....	4-29
Changing A Marker Icon .....	4-30
<b>Application Reports</b> .....	<b>4-31</b>
Application Operation Report Settings .....	4-31
Product Application Smart Report™ .....	4-32

# TABLE OF CONTENTS

---

<b>Console Setup</b> .....	<b>4-35</b>
General Console Setup Tab .....	4-35
Touch Screen Calibration .....	4-36
Display Owner Setup .....	4-37
Console Setup Memory Tab .....	4-39
Console Features .....	4-40
Advanced .....	4-40
<b>GPS Setup</b> .....	<b>4-41</b>
GPS Setup Pages .....	4-41
Further GPS References .....	4-41
<b>GPS Tabs</b> .....	<b>4-42</b>
GPS General Setup Tab .....	4-42
<b>GPS Serial Port</b> .....	<b>4-44</b>
Serial Port Settings .....	4-44
Satellite Differential Setup .....	4-46
OmniSTAR® Contact Information .....	4-47
Beacon Differential Setup .....	4-48
<b>GPS Guidance Tab</b> .....	<b>4-49</b>
<b>Operations Setup</b> .....	<b>4-50</b>
Operations Setup Basics .....	4-50
Planting And Seeding Setup .....	4-51
Tillage Operation Setup .....	4-52
Application Setup .....	4-53
Grain Harvest Yield Monitoring Setup .....	4-54
Cotton Harvest Yield Monitoring Setup .....	4-55
<b>DGPS Button</b> .....	<b>4-56</b>
GPS General Tab .....	4-56
GPS Advanced Tab .....	4-57
TSIP Receiver Tab .....	4-59
OmniSTAR® Tab .....	4-60
System Diagnostic Button .....	4-61
<b>Run Screen General Tabs</b> .....	<b>4-62</b>
Field Notes Tab .....	4-62
Using Field Notes .....	4-62
<b>Map Tab</b> .....	<b>4-64</b>
Map Tab Basics .....	4-64
Map Zoom Detail .....	4-66
Field Boundary Creation .....	4-67
 <b>CONFIGURATION</b>	
<b>Planting Setup Tabs</b> .....	<b>5-1</b>
Configuration .....	5-1
Configuration Tab Buttons .....	5-2
<b>Creating A New Configuration</b> .....	<b>5-4</b>
Configuration Basics .....	5-4
Adding A New Area Logging (Site Verification) Configuration .....	5-5
Adding A New Rate Control/Logging Configuration .....	5-8
Adding a Multi-Variety Planting Configuration .....	5-11
Adding an Additional Equipment Configuration .....	5-17
Configuration Settings .....	5-19
Automatic Swath Control Settings .....	5-20

# TABLE OF CONTENTS

---

<b>Creating A New Configuration (Continued)</b>	
Clutch Control Look-Ahead Numbers .....	5-21
Checking AutoSwath™ Performance for Clutch Control .....	5-22
Calibrate Distance.....	5-23
Auxiliary Input Settings (Switch Mapping).....	5-25
<b>Vehicle Tab .....</b>	<b>5-27</b>
Vehicle Tab Settings .....	5-27
Adding A New Vehicle .....	5-28
<b>Vehicle Tab - Advanced Settings .....</b>	<b>5-29</b>
GPS Offsets .....	5-29
<b>Implement Tab .....</b>	<b>5-30</b>
Implement Tab Settings.....	5-30
Adding A New Implement .....	5-32
<b>Implement Tab - Offsets .....</b>	<b>5-35</b>
Swath Section Offsets.....	5-35
<b>KINZE Planter Monitor .....</b>	<b>5-36</b>
KINZE® Planter Monitor Setup .....	5-37
KINZE® Planter Configuration .....	5-38
KINZE® Planter Sensor Configuration .....	5-41
Muxbus Sensor Detection (for KINZE® Planter Monitor).....	5-43
Sensor Information (for KINZE® Planter Monitor).....	5-46
KINZE® Seed Monitor Alarms .....	5-47
KINZE® Magnetic Coil Speed Sensor Calibration .....	5-48
KINZE® EdgeVac® Calibration.....	5-50
<b>Controller Tab .....</b>	<b>5-51</b>
Controller Tab Settings.....	5-51
Controller Settings for KINZE® Hydraulic Drive .....	5-52
Adding A New Controller .....	5-53
<b>Product Tab .....</b>	<b>5-55</b>
Product Tab Settings .....	5-55
Adding A New Product.....	5-56
Import Product .....	5-57
Edit Legend and Edit Info.....	5-59
<b>SeedCommand.....</b>	<b>5-60</b>
SeedCommand™ KINZE® Planter Monitor Configuration .....	5-60
SeedCommand™ Clutch Control Configuration .....	5-66
KINZE® Hydraulic Drive Configuration .....	5-73

## OPERATION

<b>Run Screen Operation .....</b>	<b>6-1</b>
Run Screen Buttons.....	6-1
<b>Run Screen Main Tabs .....</b>	<b>6-2</b>
Seed Tab (for KINZE® Planter Monitor) .....	6-2
Planting Tab (for Site Verification) .....	6-2
Planting Tab (for Clutch Control) .....	6-3
Planting Tab (for KINZE® Hydraulic Drive) .....	6-3
Field Notes Tab .....	6-3
Map Tab .....	6-3

# TABLE OF CONTENTS

---

<b>Area And Rate Logging/Control</b> .....	<b>6-4</b>
Planting Tab - Site Verification.....	6-4
Planting Flow Meter (Shaft Speed Sensor).....	6-4
Serial Controlled Planting .....	6-4
Multiple Implement Configurations.....	6-4
Target Rate .....	6-4
<b>Field Button While Not Logging</b> .....	<b>6-5</b>
<b>Region Button</b> .....	<b>6-6</b>
<b>Field Button While Logging</b> .....	<b>6-7</b>
<b>Site Verification Display Items</b> .....	<b>6-8</b>
<b>Rate Control/Logging Display Items</b> .....	<b>6-9</b>
<b>Viewable Maps</b> .....	<b>6-10</b>
<b>Map Legend</b> .....	<b>6-11</b>
<b>Clutch Control</b> .....	<b>6-12</b>
<b>KINZE® Planter Monitor</b> .....	<b>6-13</b>
KINZE® Planter Monitor Options .....	6-15
KINZE® Planter Control .....	6-16
KINZE® Hydraulic Drive Seed Meter Calibration .....	6-17
KINZE® Seed Meter Prime (Hydraulic Drive feature) .....	6-20
<b>System Diagnostic Button</b> .....	<b>6-21</b>
<b>Troubleshooting</b> .....	<b>6-23</b>
 <b>APPENDIX</b>	
KINZE Vision® Display General Menu Tree .....	7-1
KINZE® Planter Monitor Run Screen .....	7-2
SeedCommand™ Menu Tree .....	7-3
GPS/Guidance Menu Tree .....	7-4
<b>KINZE Vision® File Formats</b> .....	<b>7-5</b>
<b>Module LED Diagnostic States</b> .....	<b>7-6</b>
 <b>KINZE VISION® PLANTER CONTROL SYSTEM QUICK REFERENCE GUIDE</b>	
<b>General Setup</b> .....	<b>8-1</b>
<b>Planting Configuration Procedure</b> .....	<b>8-2</b>
<b>Implement Options</b> .....	<b>8-4</b>
KINZE® Planter Monitor Setup .....	8-4
Configure Clutch Module .....	8-4
<b>Controller Settings</b> .....	<b>8-5</b>
Channel Tabs .....	8-5
Auxiliary Tab.....	8-5
<b>Run Screen</b> .....	<b>8-6</b>
<b>Functionality and Display Items</b> .....	<b>8-6</b>
<b>3600V Wiring Diagram</b> .....	<b>8-8</b>

# TO THE OWNER

---

KINZE Manufacturing, Inc. would like to thank you for your patronage. We appreciate your confidence in KINZE® farm machinery. Your KINZE Vision® Planter Control System equipped planter has been carefully designed to provide dependable operation in return for your investment.

**This manual has been prepared to aid you in the operation of your planter control system display. It should be considered a permanent part of the machine and remain with the machine when you sell it.**

It is the responsibility of the user to read and understand this Operator Manual with regard to safety, operation and maintenance before operation of this system. It is the user's responsibility to inspect and service the control system routinely as directed in the Operator Manual. We have attempted to cover all areas of safety, operation, and maintenance; however, there may be times when special care must be taken to fit your conditions.

As related to the planter control system display, the use of "**NOTE**" and "**IMPORTANT**" are defined below and are used to call attention to information related to system operation and proper operating practices to prevent accidental data loss. If doubting the results of performing an action or deleting an item from the system, back up all system files to the external storage card before proceeding with the action.

**NOTE:** Indicates information that will assist with system setup, calibration, and operation.

**IMPORTANT:** Indicates specific settings, calibrations, and procedures that must be followed for proper system performance and operation, and for preventing the accidental loss of data and/or system configuration settings.

Throughout this manual the symbol  and/or the words **CAUTION**, **WARNING** or **DANGER** are used to call your attention to important information. The definition of each of these terms follows:



**CAUTION:** Indicates a potentially hazardous situation which, if not avoided, may result in minor or moderate personal injury.



**WARNING:** Indicates a potentially hazardous situation which, if not avoided, could result in death or serious personal injury.



**DANGER:** Indicates an imminently hazardous situation which, if not avoided, will result in death or serious personal injury.



**WARNING:** Some photos in this manual may show safety covers, shields or lockup devices removed for visual clarity. **NEVER OPERATE** the machine without all safety covers, shields and lockups in place.

**NOTE:** Some photos in this manual may have been taken of prototype machines. Production machines may vary in appearance.

# WARRANTY

---

The KINZE® Limited Warranty for your new machine is stated on the back of the retail purchaser's copy of the Warranty And Delivery Report form. Additional copies of the Limited Warranty can be obtained through your KINZE® Dealer.

Warranty, within the warranty period, is provided as part of KINZE's support program for registered KINZE® products which have been operated and maintained as described in this manual. Evidence of equipment abuse or modification beyond original factory specifications will void the warranty. Normal maintenance, service and repair is not covered by KINZE® warranty.

To register your KINZE® product for warranty, a Warranty And Delivery Report form must be completed by the KINZE® Dealer and signed by the retail purchaser, with copies to the Dealer, to the retail purchaser and to KINZE Manufacturing, Inc. Registration must be completed and sent to KINZE Manufacturing, Inc. within 30 days of delivery of the KINZE® product to the retail purchaser. KINZE Manufacturing, Inc. reserves the right to refuse warranty on serial numbered products which have not been properly registered.

If service or replacement of failed parts which are covered by the Limited Warranty are required, it is the user's responsibility to deliver the machine along with the retail purchaser's copy of the Warranty And Delivery Report to the KINZE® Dealer for service. KINZE® warranty does not include cost of travel time, mileage, hauling or labor. Any prior arrangement made between the Dealer and the retail purchaser in which the Dealer agrees to absorb all or part of this expense should be considered a courtesy to the retail purchaser.

*KINZE® warranty does not include cost of travel time, mileage, hauling or labor.*

# INTRODUCTION

The KINZE Vision® Planter Control System Display is a GPS-compatible universal monitor/controller for use in crop production and protection. It can easily be transferred between multiple vehicles throughout the growing season to maximize your return on investment.

The KINZE Vision® display has its own internal memory for recording GPS and logging all information collected during various field activities.

The KINZE Vision® display has been built to withstand the harsh environment associated with today's agricultural industry. The weathertight enclosure is designed to seal out any dirt and moisture that is encountered during normal operating conditions.

## GENERAL INFORMATION

The information used in this manual was current at the time of printing. However, due to KINZE's continual attempts to improve its product, production changes may cause your planter control system display to appear or operate slightly different in detail. KINZE Manufacturing, Inc. reserves the right to change specifications or design without notice and without incurring obligation to install the same on machines previously manufactured.

Right hand (R.H.) and left hand (L.H.), as used throughout this manual, are determined by facing in the direction the machine will travel when in use, unless otherwise stated.

D012908205



# INTRODUCTION

---

**This page intentionally left blank.**

# SPECIFICATIONS

## KINZE VISION® PLANTER CONTROL SYSTEM DISPLAY

Absolute Voltage Range . . . . .	0 to 60v
Audio . . . . .	Integral Speaker With Volume Control
Card Slot. . . . .	(1) Type 1 Compact Flash Slot
Connector. . . . .	(1) 28-Pin AMP
Display Features. . . . .	sunlight readable; backlight intensity control
Display Size . . . . .	10.4" Diagonal Color LCD; 640 x 480 Resolution
Enclosure . . . . .	High Impact Polycarbonate - Chemical And UV Resistant
Environmental Operating Temperature. . . . .	14° to 149°F
Full Function Voltage Range. . . . .	8 to 18v
Input/Output . . . . .	CAN, Serial Port (RS232)
Maximum Current Draw . . . . .	2A
Mount Dimensions . . . . .	1½" Diameter Balls And 5" Arm Length
Mounting System . . . . .	Ram® Mount
Operating Voltage Range . . . . .	6 to 19v
Outside Dimensions . . . . .	11.6" x 8.9" x 2.4"
Power Loss Protection for Shutdown . . . . .	Yes
Power Override Button . . . . .	Yes
Reverse Voltage Protection . . . . .	Yes
Storage Temperature . . . . .	-22° to 158°F
Touch Screen Area . . . . .	11.2" Diagonal; Chemical Resistant
Weight. . . . .	4.8 lbs.

D012908205

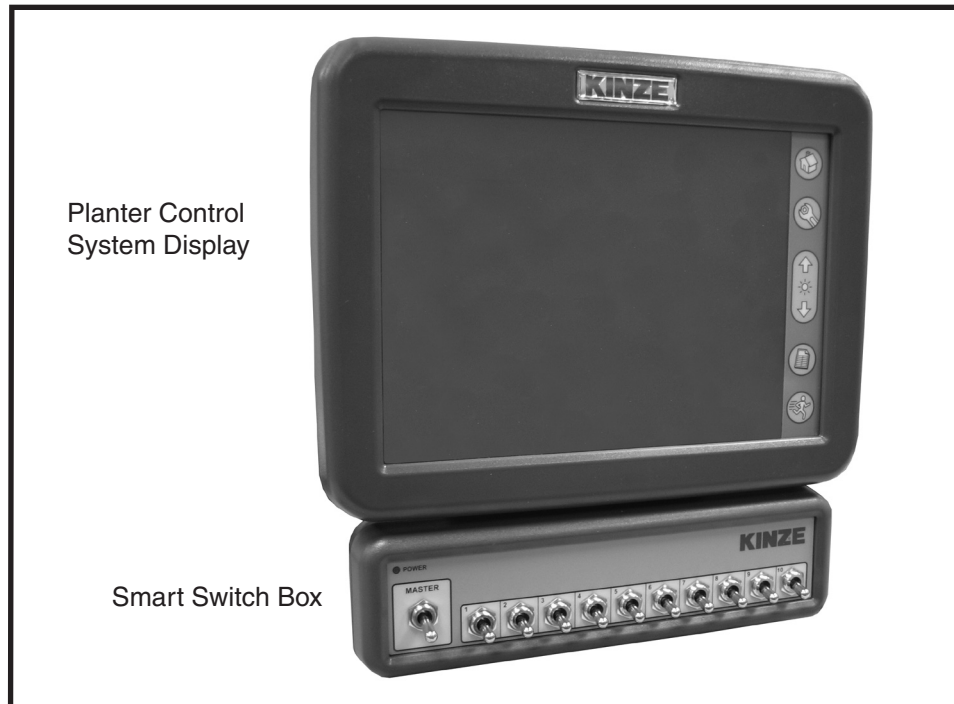

Planter Control System Display

Smart Switch Box

## SMART SWITCH BOX

Enclosure . . . . .	High Impact Polycarbonate/ABS - Chemical And UV Resistant
Outside Dimensions . . . . .	10.4" x 2.9" x 2.1"
Weight. . . . .	1.8 lbs.

# SPECIFICATIONS

---

**This page intentionally left blank.**

## KINZE VISION® SYSTEM

The KINZE Vision display is a GPS-compatible universal monitor/controller for use in crop production and protection. It can easily be transferred between multiple vehicles through out the growing season to maximize your return on investment.

The KINZE Vision display has its own internal memory for recording GPS and logging all information collected during various field activities.

The KINZE Vision display has been built to withstand the harsh environment associated with today's agricultural industry. The weathertight enclosure is designed to seal out any dirt and moisture encountered during normal operating conditions.

**NOTE: The card door slot must be fully closed for the KINZE Vision display to remain weathertight.**

### System Use

- Grain Yield Monitoring
- Hybrid Variety Tracking
- Liquid Spray System Control
- AutoSwath Boom Section Control
- NH<sub>3</sub> Application Control
- Granular And Liquid Fertilizer Application
- Multiple Product Application
- Mapping Tillage Operations
- Mapping And Logging Product Application
- Mapping Of All Field Boundaries, Sub-boundaries, Waterways And Terraces
- Split Planter Data Mapping And Recording

**NOTE: For a complete description of all supported file types and their uses, see "KINZE Vision® File Formats" on page 7-5.**

### System Features

- Large 10.4-inch Display
- Sunlight-Readable Screen
- Large Internal Memory
- Rugged Sealed Enclosure
- On-screen Help With Detailed Operating And Configuration Information
- Compatible With Most NMEA GPS Receivers
- Direct Access Keys Give You One-touch Access To Home, Setup, Summary/report, And Run Screens
- DirectCommand™ Product Control Using Industry-standard Can-bus Interface
- Adjustable Volume Control
- Backed By A 2-year Warranty

## Data Card Usage

The KINZE Vision uses a Compact Flash Card for transferring data in and out of the display. The system is compatible with all current card sizes; 64 MB is the minimum recommended size for use with the system.

## Color Touch Screen

The KINZE Vision display features a 10.4 inch color touch screen display. The touch screen allows easy and intuitive navigation through the screens on the display without the need for any external keypad or mouse devices. Here are a few key things to remember if you are new to using a touch screen device.:

Do not use any sharp objects for running the touch screen device, this could result in damage to the display. Using the tip of a finger is the recommended.

Do not use any harsh chemicals to clean the touch screen. Using a damp soft cloth or an anti-static wipe made specifically for cleaning computer displays is the correct way to clean the screen and enclosure.

The touch screen requires only a gentle touch of about ½ second in duration to operate correctly.

A common mistake new users make is to try to navigate too quickly through the system using firm taps instead of gentle presses on the display screen.

## CAN-bus Technology

The KINZE Vision system uses Controller Area Network (CAN) technology. CAN systems are comprised of individual modules, each with their own high speed processor, connected through a high-speed communications cable. CAN has many benefits including greater ability to configure and expand the system, compatibility, simpler installs with less wiring and increased system dependability.

## System Upgrades

KINZE will periodically provide operating program updates to improve system performance. Required software updates will be available free of charge for download from [www.kinze.com](http://www.kinze.com). On occasion, major releases will be made available that have significant product feature additions or enhancements. These optional software updates may have an additional fee associated with them.

## Cross-References

Throughout this manual, numerous cross-references are provided to other pages or sections. These cross-references are always shown in italic text; and list the title and page number as in the following example:

## KINZE® PLANTER CONTROL SYSTEM WIRING DIAGRAM

VI22

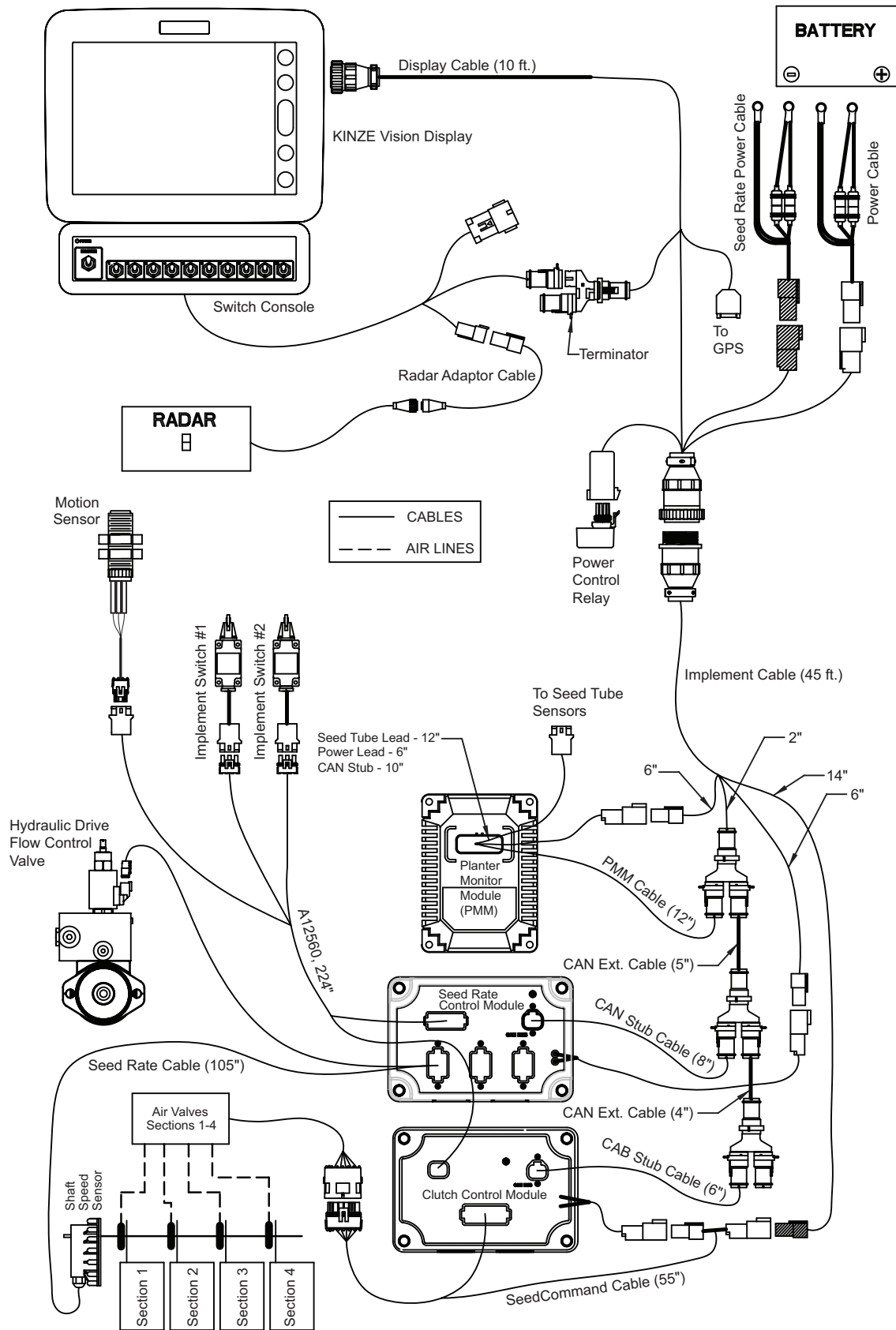

---

## KINZE VISION® PLANTER CONTROL SYSTEM INSTALLATION INSTRUCTIONS

All machine installation and mounting kits are shipped with instructions specific to that kit. Instructions include special details relating to mounting, wiring and display configuration.

### Mounting The KINZE Vision® Display

Mount the display to a secure support inside the vehicle cab. The following must be considered when choosing a mounting location.

- The display must be readily accessible to the machine operator.
- The display must not obstruct the machine operator's normal driving view.
- The display must not interfere with or limit access to any of the existing machine controls.
- Route and secure the KINZE Vision system cabling without interfering with other machine controls.

**IMPORTANT: If drilling holes is required during the mounting process, care must be taken to ensure that damage is not done to existing vehicle wiring, mechanicals, or cab structure. Refer to vehicle manufacturer documentation for specific details on your equipment. Follow all OEM instructions, cautions, and warnings when working around equipment.**

## Display Hardware

D012908100

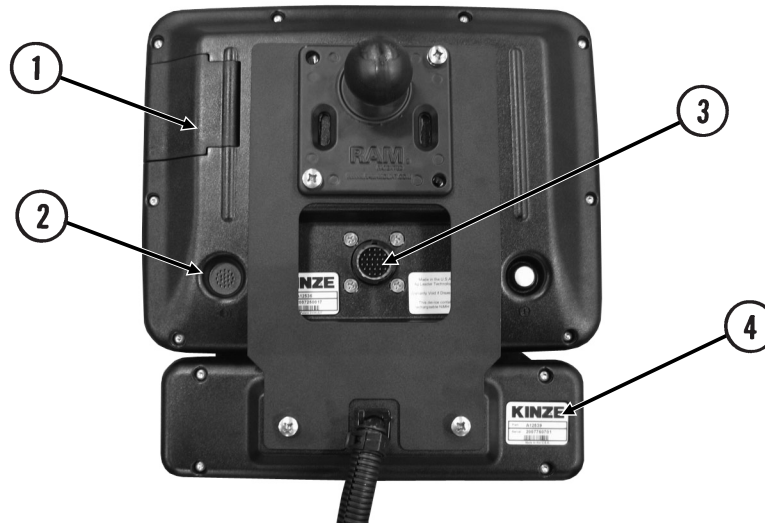

Rear View - KINZE Vision® Display

Item	Description
<b>1) Compact Flash Card Slot</b>	The compact flash card slot has a sensor that allows the display to know when the door is open or closed. If the door is opened when a card is in the display, an on-screen warning will appear indicating when the card can safely be removed. The KINZE Vision display comes with a compact flash card. The compact flash card will be required to transfer files from the KINZE Vision to a desktop computer.
<b>2) Speaker</b>	The built-in speaker is used for audible warnings. The speaker volume can be adjusted using the console setup routine.
<b>3) 28-Pin Connector</b>	The 28-Pin round connector contains CAN, RS-232 serial, and system power and ground connections.
<b>4) Power/Reset Switch</b>	The Power/Reset switch is used for turning the KINZE Vision display on and off in installations where the system is connected to a continuous power supply. If the KINZE Vision display ever stops responding, the manual power switch may be held in for five seconds to restart the system. Only do this as a last resort, data loss could occur during times of improper shutdown.

## KINZE VISION® SYSTEM POWER UP



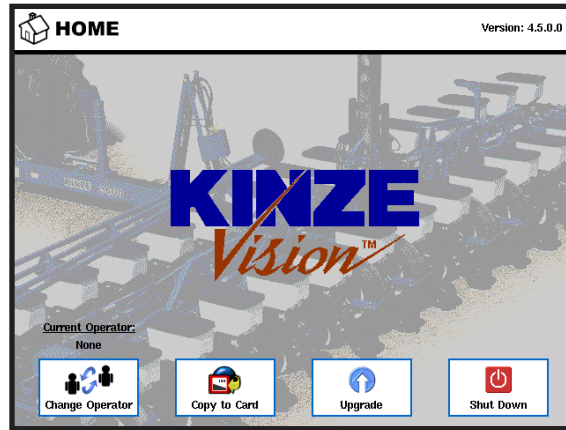

The KINZE Vision display comes with an AC power supply. Using the AC power supply, familiarize yourself with the system features. We suggest taking the time to step through the initial configuration process with the aid of this user guide prior to installing any of the KINZE Vision system hardware in your equipment.

## Home Screen

The Home Screen will be shown each time the KINZE Vision display is started. The table below describes the functionality of each of the buttons present on the Home screen.



**KINZE Vision® Home Screen**

Button	Description
 <p>Change Operator</p>	<p>Press to select a machine operator from the drop down list. Machine operator information will be logged with all field operations.</p>
 <p>Copy to Card</p>	<p>Press to copy all logged data files to the external storage card and remove from the internal memory of the display.</p>
 <p>Upgrade</p>	<p>Press to load program upgrade files from the external storage card.</p>
 <p>Shut Down</p>	<p>Press to shut down the KINZE Vision system.</p>



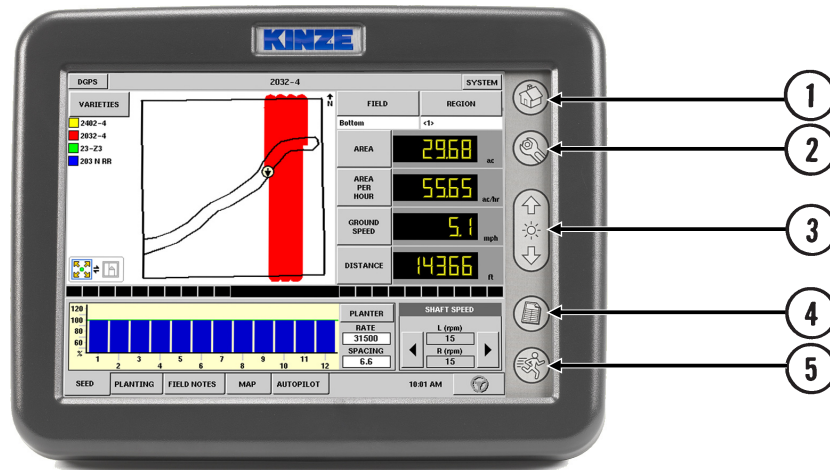

## SYSTEM NAVIGATION BUTTONS

The system navigation buttons on the right side of the KINZE Vision display are used to move between the different areas within the system. The Navigation button functionality is consistent throughout all modes of operation.

For more information on the System Navigation buttons, see “KINZE Vision® Display General Menu Tree” on page 7-1.



**System Navigation Buttons**

Navigation Buttons	Description
1)  <b>Home</b>	Press to access the Home screen on the KINZE Vision display. Options available at the Home screen are Copy to Card, Upgrade System, User Guide, Change Operator and Shut Down.
2)  <b>Setup</b>	Press to access the menus and wizards used for system configuration. General setup item groups include, Grower-Field Management, Field Notes, Console, and GPS configurations. Use specific setup item groups include Planting, Product Application, Tillage, and Harvest configurations.
3)  <b>Brightness</b>	Press the Brightness Control to set display back light intensity to fit current operating conditions.
4)  <b>Summary</b>	Press to display a summary screen showing totals for the current field operation you are performing.
5)  <b>Run</b>	Press to launch the Run Screen. The Run Screen provides control of all field operations and the data logging associated with Harvest, Planting, Tillage, and Product Application.

## RUN SCREEN COMMAND BUTTONS

Regardless of the current mode of operation, these common buttons and the associated functionality is always present at the run screen. For more information on the Run screen command buttons, see “KINZE® Planter Monitor Run Screen” on page 7-2.

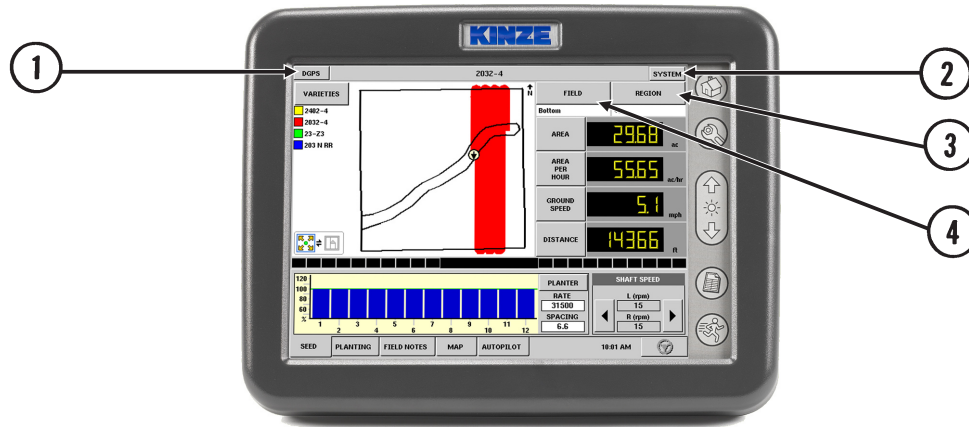

Run Screen - Planting Mode

Run Screen Buttons	Description
1) <b>DGPS</b>	Displays the quality of GPS signal in use by the system. If both differential and GPS signals are available, this button will display <b>DGPS</b> . If GPS is available without differential correction, the button will display <b>GPS</b> . If neither GPS or differential signal is available, two dashed lines (--) will be displayed on the button. Press the <b>DGPS</b> button to display detailed GPS and differential correction information. For more information, see “GPS General Tab” on page 4-56.
2) <b>SYSTEM</b>	Press to launch information screens that include various tabbed pages for display of system operating status. These pages include statistics on memory usage, diagnostics, and readings from various sensors and system components connected to the KINZE Vision display. For more information, see “System Diagnostic Button” on page 4-61.
3) <b>REGION</b>	A region is used to subdivide a field into smaller sections. The region that is currently being logged to is shown below the <b>REGION</b> button. A new region can be created at any time as you are performing a field operation. To change between or add a new region to a field, press the <b>REGION</b> button and follow the on screen instructions.  <b>NOTE: Regions and Fields are created in the Run Screen’s Grower/Field Management Setup. Both are discussed in greater detail within each Operation section of this manual (such as Planting, Tillage, etc.).</b>
4) <b>FIELD</b>	The field that is currently being logged to is shown below the <b>FIELD</b> button. To change Fields, press the <b>FIELD</b> button and select the desired field. The Operating Configuration and Product are also selected during this process.

## RUN SCREEN DISPLAY AREA

The following tables describe the main features and functionality of the Run screen. These features remain constant between the different modes of operation.

For more information on this Run screen display area, see “KINZE® Planter Monitor Run Screen” on page 7-2.

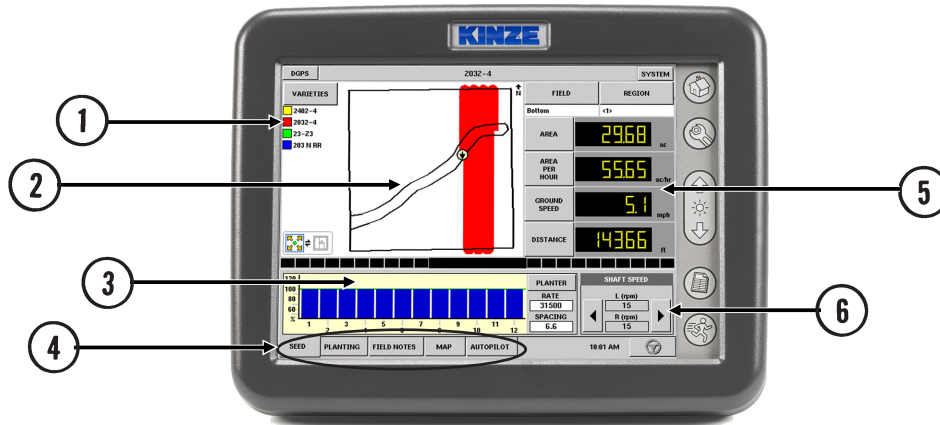

**Run Screen - Planting Mode**

Item	Description
<b>1) Legend</b>	This area displays a choice of several legends appropriate to the type of field operation taking place. By pressing the legend, a dialog is displayed that allows creating and saving custom legends.
<b>2) Map Area</b>	This area of the screen is dedicated to displaying the many different map objects available in the KINZE Vision system. Depending upon the selected field operation, one or more of the following different maps are made available. <ul style="list-style-type: none"> <li>• Field Boundaries</li> <li>• Crop Yield And Moisture</li> <li>• Planter Variety</li> <li>• Field Notes Marks</li> <li>• Prescription Maps</li> <li>• Applied Rate Maps</li> <li>• Product Coverage Maps</li> <li>• Reference Map</li> </ul>
<b>3) Swath Bar</b>	This area of the Run screen displays the current swath of operation being performed in the field.
<b>4) Control Tabs</b>	Each Control tab contains content specific to the current mode of operation. Examples of the various tabs functionality include using the Field Notes feature, viewing and setting product control parameters.

## DISPLAY ITEMS AND AREA COUNT

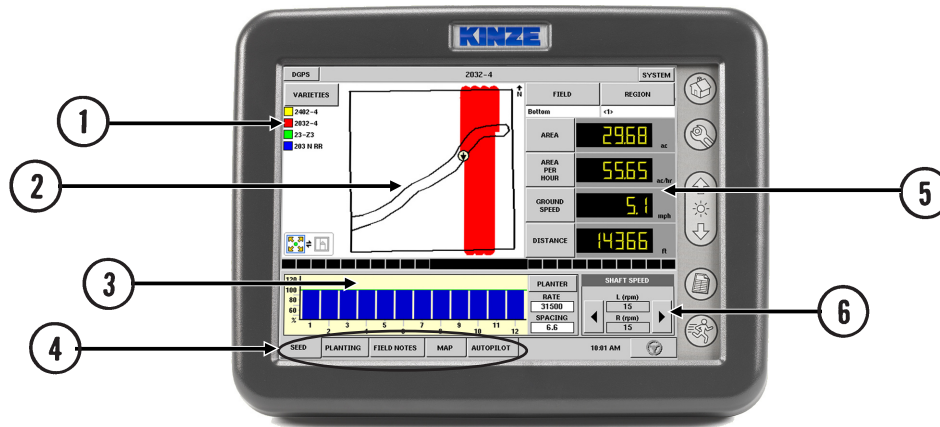

**Run Screen - Planting Mode**

Display Areas	Description
<p><b>5) Run Screen Display Items</b></p>	<p>This area of the screen displays four different data items. The type of field operation being performed determines what items are available. The selection and order of the four display items can be changed by pressing on that item and choosing a different data item from a pop-up list. In planting mode, the following display items are available:</p> <ul style="list-style-type: none"> <li>• Area</li> <li>• Area Per Hour</li> <li>• Ground Speed</li> <li>• Distance</li> </ul>
<p><b>6) Area Count Status</b></p>	<p>This button is present when appropriate during harvest, planting or tillage operations and any other time data is being logged to the system without controlling application rate. The button functions as a master area count on/off switch. Area count can be turned on/off manually by pressing the button or will turn on/off automatically when a header or implement switch is being used with the current operating configuration.</p>

## GETTING STARTED

### Entering Data Into The KINZE Vision® Display

The following control buttons are made available for entering names and calibration values into the system.

Function Button	Data Entry Screen
<div data-bbox="181 596 331 697" data-label="Image"> </div> <p data-bbox="181 705 537 926">An on-screen <b>Keyboard</b> is made available when appropriate for use during all setup processes. Press the keyboard button to access the on-screen text entry screen shown at right.</p>	<div data-bbox="743 569 1300 984" data-label="Image"> </div>
<div data-bbox="181 1243 280 1350" data-label="Image"> </div> <p data-bbox="181 1356 545 1608">An on-screen <b>Numeric Keypad</b> is made available for changing configuration settings and calibration numbers. Press the keypad button to access the on-screen numeric entry screen shown at right.</p>	<div data-bbox="743 1276 1300 1692" data-label="Image"> </div>

## SETUP TIPS

### Setup Wizard Use

Most configuration of the KINZE Vision system is accomplished by using setup wizards. Setup wizards are a series of on-screen dialogs that move the user through the configuration process in a simple to follow step-by-step manner.

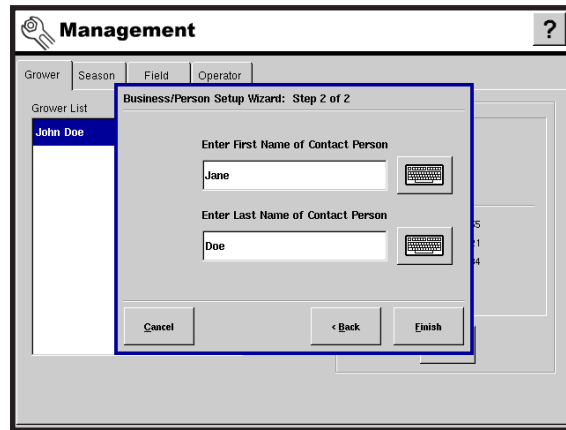

Setup Wizard Dialog Example

### System Functionality

Much of the functionality of the KINZE Vision system is not available at the Run screen until the basic setup process is completed. Prior to initial setup the Run screen will look like the following figure. Other than the information available under the **DGPS** (--) and **SYSTEM** buttons no functionality will be present.

Required initial system configuration steps include the following:

- Grower/Field Management Setup
- Equipment Operating Configuration Setup
- Product Setup





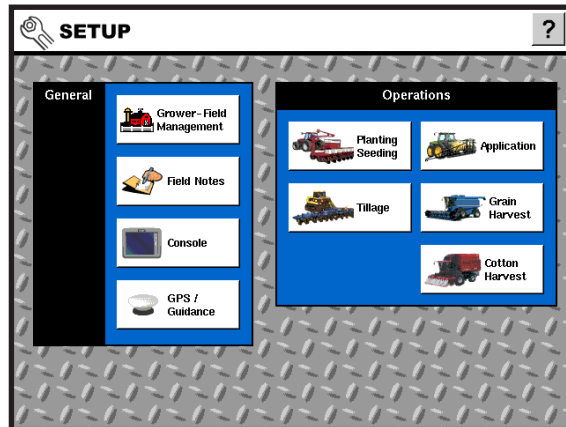

Run Screen Prior to System Setup

## GENERAL SETUP OVERVIEW



**Main Setup Screen**

This section of the KINZE Vision User Guide covers the setup items and processes that are common to all operations within the KINZE Vision system. All setup screens and wizards are made available by pressing on each of the buttons on the General Setup section of the KINZE Vision display. Below is a description of the basic functionality of each of the main control buttons, with cross references to more descriptive information.

Setup Button	Description
	Press to access the Management screen where Grower, Season, Field, and Machine Operator are set up and edited. For more information, see <i>“Management Data Setup”</i> on page 4-13.
	Press to access the Field Notes function setup. Field Notes are tools that allow marking points and logging data to those points while performing any field operations while in the run screen. Settings related to automating product application reporting are also contained in Field Notes setup. For more information, see <i>“Field Setup”</i> on page 4-20; as well as <i>“Field Notes Setup Screen”</i> on page 4-27 and <i>“Using Field Notes”</i> on page 4-63.
	Provides access to setting date/time, unit of measure settings, display owner information setup, unlocking any optional features purchased with the system, as well as some basic memory and storage card maintenance functionality. For more information, see <i>“Console Setup”</i> on page 4-35.
	Press to configure TSIP GPS receiver systems. For detailed information, see <i>“GPS General Setup Tab”</i> on page 4-42.

## ON SCREEN HELP

	On screen help is made available by pressing the Help button in the upper right corner of the KINZE Vision screen.
---	--

## FIELD OPERATION DATA STORAGE

All data is stored in a hierarchical data structure for use within the KINZE Vision system and desktop GIS software packages. As needed, the on-screen keyboard is made available for typing when performing actions like naming Growers and Fields.

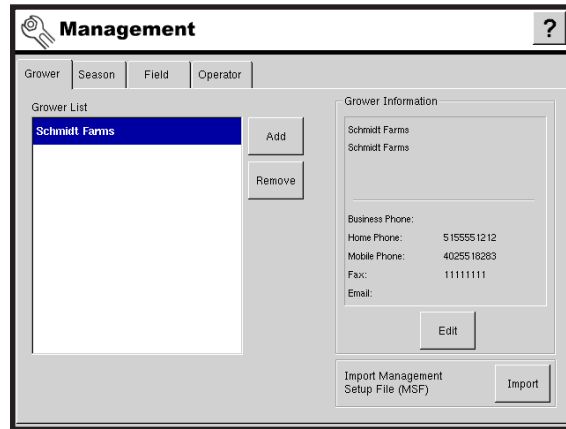

Setup Tab	Description
<b>Grower</b>	The <b>Grower Tab</b> is used to set up the businesses or people that own one or more farms. For more information, see <i>“Grower Setup Screen” on page 4-14.</i>
<b>Season</b>	The <b>Season Tab</b> is used to set up the crop season. The season is defined as the calendar year that the crop, relating to the current field operation, will be planted. For more information, see <i>“Season Setup Screen” on page 4-15.</i>
<b>Field</b>	The <b>Field Tab</b> is used to set up fields and all descriptive information relating to them. For more information, see <i>“Field Setup Screen” on page 4-20.</i>
<b>Operator</b>	The <b>Operator Tab</b> is used to set up machine operator and Certified Custom Applicator license information. For more information, see <i>“Operator Setup Screen” on page 4-24.</i>



## GROWER SETUP SCREEN

The Grower is a global setting that refers to the business or person that the system is in operation for.

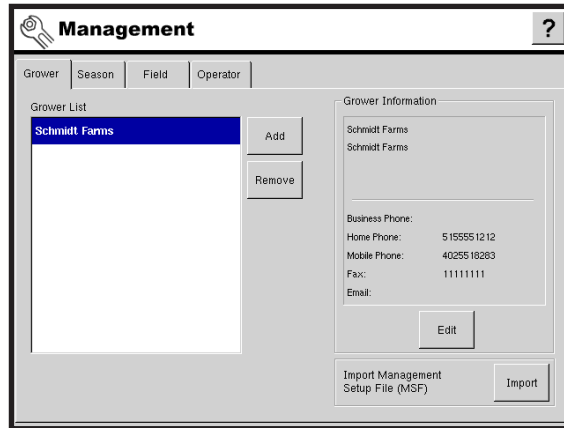
Contact information can also be entered for each grower. The Grower information will be passed into mapping software for automatic Grower setup within desktop software.

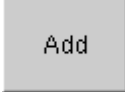
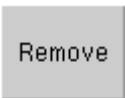

**Grower Management Screen**



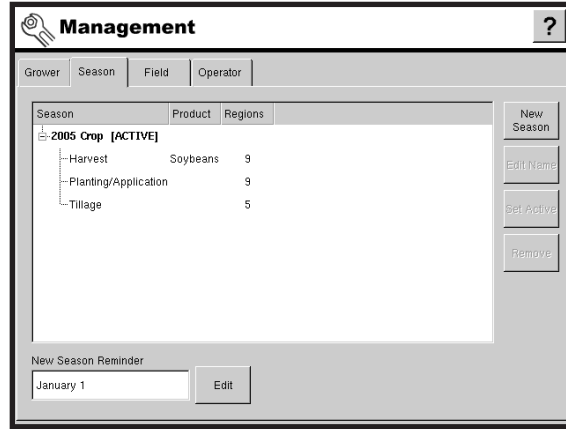

Item	Description
<b>Grower List</b>	Displays all Growers configured within the KINZE Vision system.
	Press to launch the software wizard used to create a new grower. For more information, see <i>“Adding A New Grower” on page 4-16.</i>
	Press to remove a selected entry in the Grower list. When the Remove button is pressed the following warning will be presented allowing the user to cancel the remove process if desired.  <b>IMPORTANT: When deleting a grower, all fields and regions relating to that grower are also deleted.</b>
<b>Grower Information</b>	This region of the screen displays all the optional information that is stored for a specific Grower.
	Press to access a data entry screen for adding or editing the optional Grower information. For more information, see <i>“Adding or Editing Grower Personal Information” on page 4-17.</i>
<b>Management Setup File (MSF)</b>	Displays the Import button used for .MSF files.
	Press to import a Management Setup File (.MSF) of Grower, Farm and Field information exported from desktop software and stored on your Compact Flash Card. For more information, see <i>“Importing A Management Setup File” on page 4-18.</i>

## SEASON SETUP SCREEN

A season is defined as the calendar year that the crop will be planted. Creating a season and setting it to active is required prior to the system logging any data.



Season Setup Screen

Item	Description
<b>Summary List Box</b>	Displays a list of all seasons setup in the KINZE Vision display.
	Press to create a new season. When a new season is created, it is set to active by default. No data will be logged to any inactive seasons that are present in the KINZE Vision display.
	Press to edit the name of the season currently selected in the summary list box.
	Press to set the season selected in the Summary list box to the active season. <b>NOTE: All data is logged to the active season.</b>
	Press to remove the season that is currently selected in the Summary list box. <b>IMPORTANT: All operations, regions, and maps for a season will be deleted when the season is removed.</b>
<b>New Season Reminder</b>	Press to set the date that the system will prompt the user to create a new season.

## ADDING A NEW GROWER

The following screen shots represent the steps involved with setting up a new Grower.

### STEP 1 Select Grower

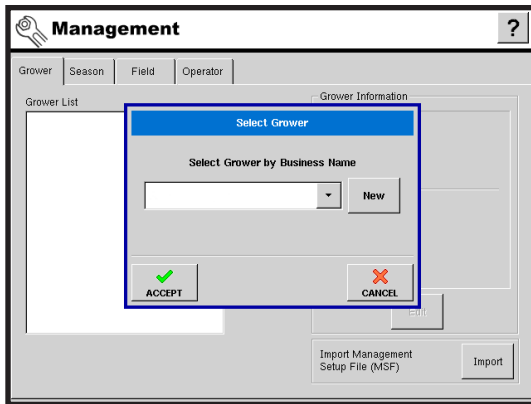

After pressing the **Add** button on the Grower screen, the Select Grower dialog is shown. The drop down list box displays all businesses within the system and makes them available for selection as a Grower. If the Grower is not present in the system as a business contact or machine operator, press the **New** button to start the process of adding new grower information.

### STEP 2 Business/Person Setup

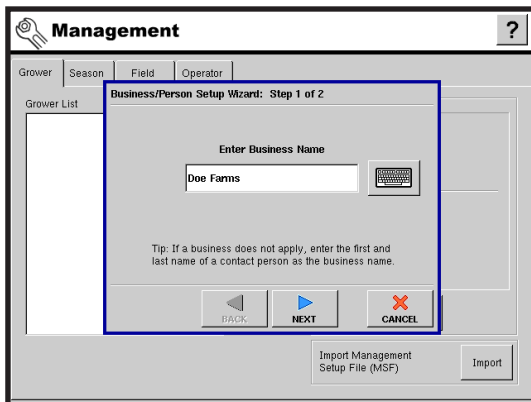

Because in most cases Growers are Business or Farm owners, the first step of the setup process asks that a Business Name be entered into the system. On the rare occasion that the grower is neither a business or farm owner, it is recommended that the person's first and last name be entered as a Business Name.

**NOTE: If you are using desktop software, it is recommended that you use the same names as in the software.**

After entering the Business Name into the system, press **Next** to proceed to the final step in the setup process.

### STEP 3 Business/Person Setup

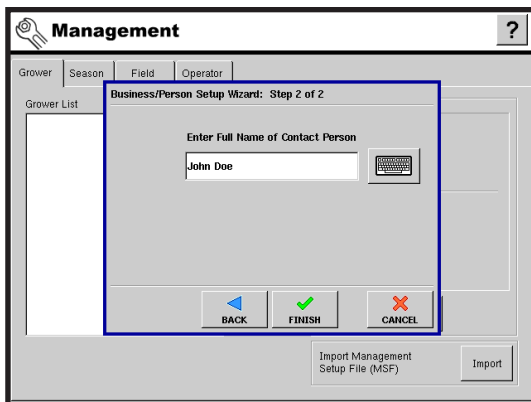

Enter the first and last name to be used as a contact for the Grower information then press **Finish** to complete the new Grower setup process.

## ADDING OR EDITING GROWER PERSONAL INFORMATION

### STEP 1 Accessing the Edit Screen

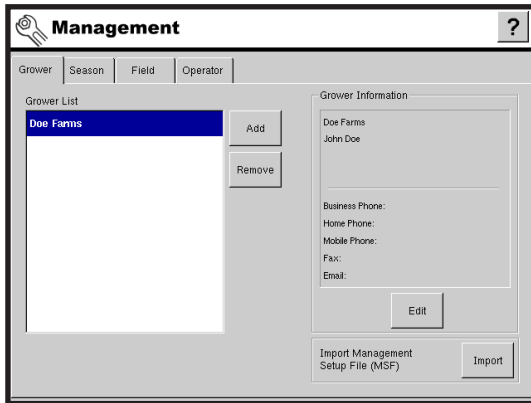

Select a Grower from the Grower List and press the **Edit** button to enter or edit any of the data displayed in the Grower Information frame.

### STEP 2 Personal Information Data Entry

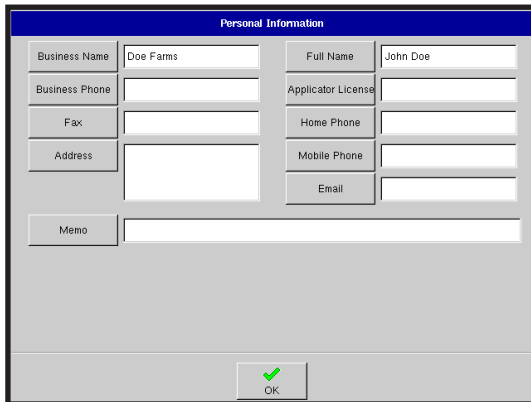

After pressing the desired control button, the on-screen keyboard or numeric keypad will show to allow data entry into the system. Press OK to complete the process.

**NOTE:** Information on the screen can be added or edited at any time.

## IMPORTING A MANAGEMENT SETUP FILE

A Management Setup File (.MSF) is a file format that allows the KINZE Vision display to import Grower and Field information from desktop software via a Compact Flash Card. Follow the process outlined below to import desktop software information from your Compact Flash Card.

### STEP 1 Press The Import button

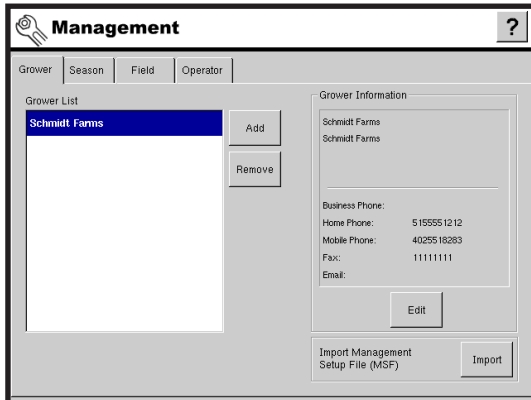

Press the **Import** button on the Grower tab of the Management screen. (Be sure that your Compact Flash Card is already inserted in the KINZE Vision display).

### STEP 2 Locate Your File On The Compact Flash Card

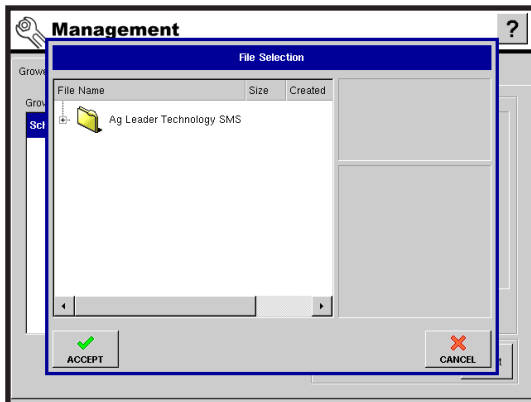

The File Selection Screen appears. The folder titled "Ag Leader Technology SMS" contains your .MSF files. Open this folder by pressing the **Plus** (+) sign to the left of the folder.

### STEP 3 Accept The .MSF File

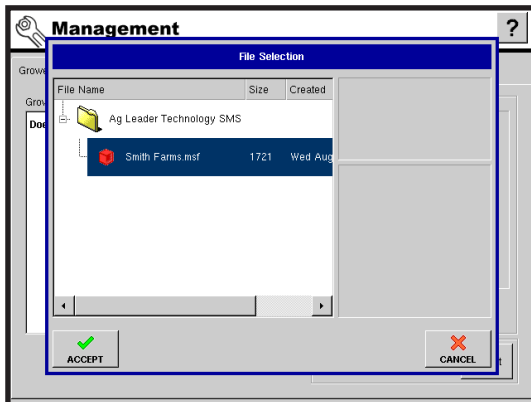

Press the .MSF file to highlight it. A blue bar highlights your selected .MSF file, as shown at left. Press the **Accept** button to import this file.

## IMPORTING A MANAGEMENT SETUP FILE (CONTINUED)

### STEP 4 KINZE Vision® Displays Information From .MSF

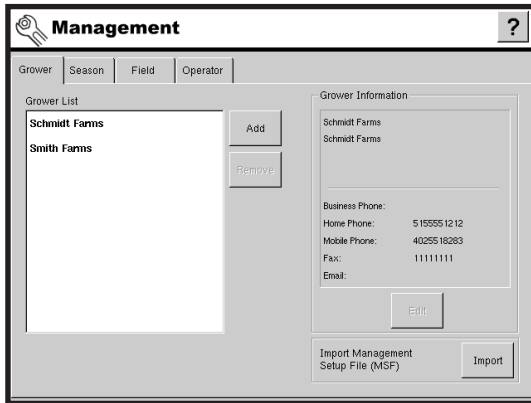



The Grower information now appears in the Grower tab of the Management screen. In the example at left, information for Smith Farms now appears on the Management screen.

## FIELD SETUP SCREEN

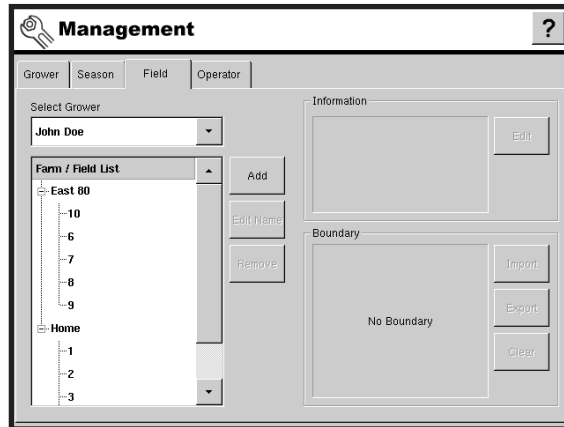
A field consists of one or more outer boundaries. Each outer boundary can contain one or more inner boundaries used to define any combination of roadways, waterways, building sites, or bodies of water. If the display will be used for multiple Growers, enter each Grower business name and associate the field names with the correct grower when the fields are setup within the system.





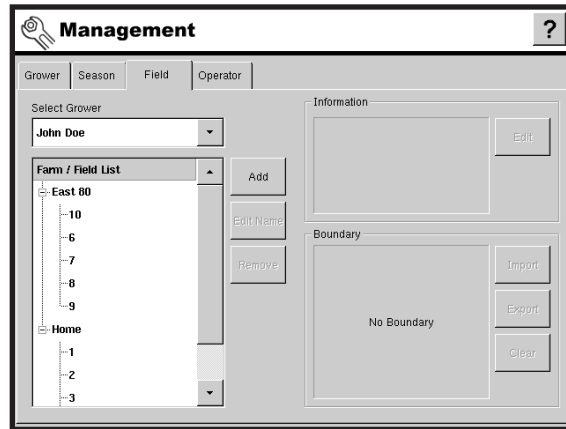

Field Setup Screen

Display Areas and Buttons	Description
<b>Select Grower</b>	Used to select which grower's fields to display in the Farm/Field list.
<b>Farm/Field List</b>	Displays a list of all farms and fields associated with the selected grower.
	Press to launch the new field creation wizard. For more information, see <i>"Adding A New Field"</i> on page 4-22.
	Press to edit the name of the item selected in the Farm/Field list.
	Press to remove the item selected in the Farm/Field list. <b>IMPORTANT: When a farm is removed, all fields and the accompanying data will be deleted. When a field is removed, all data for that field will be deleted.</b>

FIELD SETUP SCREEN (Continued)



Field Setup Screen

Display Areas And Buttons	Description
<b>Information Frame</b>	When a farm is selected in the Farm/Field list, the grower name is displayed in this frame. When a field is selected in the Farm/Field list, all descriptive text for legal description and field geographic location is displayed in this frame.
	Press to add or edit any of the information stored for the field selected in the Farm/Field list.
<b>Boundary Frame</b>	When a field is selected in the Farm/Field list any collected boundaries and total area will be displayed in this frame. For more information on creating field boundaries, see <i>“Field Boundary Creation”</i> on page 4-67.
	Press to import a field boundary from the external storage card. For more information, see <i>“Importing/Exporting Boundaries”</i> on page 4-23.
	Press to export a selected field boundary to the external storage card. For more information, see <i>“Importing/Exporting Boundaries”</i> on page 4-23.
	Press to delete a field boundary from the system. <b>IMPORTANT: All inner and outer boundaries associated with a field will be deleted from the system when clearing a boundary.</b>

## ADDING A NEW FIELD

### STEP 1 Select Farm

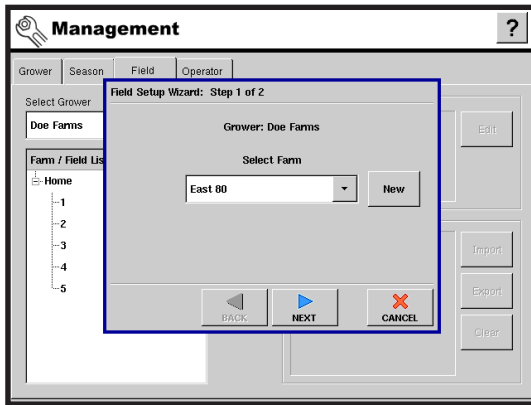

Use the drop down list to choose the correct Farm. To enter a new Farm name press the **New** button and use the on-screen keyboard to enter in a name.

Press **NEXT** to continue.

### STEP 2 Add Field Name

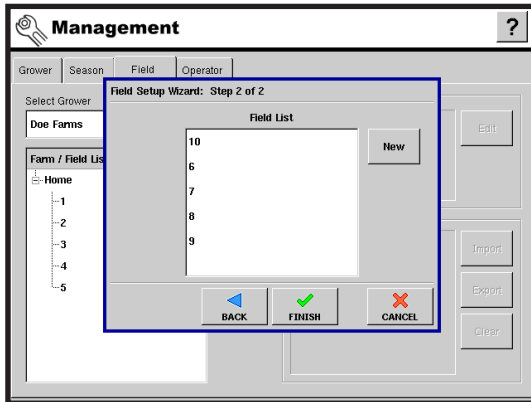

Use the **New** button to enter the new Field name. More than one field can be created at this time.

Press **FINISH** to complete the setup process.

## IMPORTING/EXPORTING BOUNDARIES

### Field Boundaries

Boundaries can be created with the KINZE Vision display or imported from desktop GIS software. Any boundary files present in the KINZE Vision display can also be exported for use in desktop mapping software.

#### Boundary Import

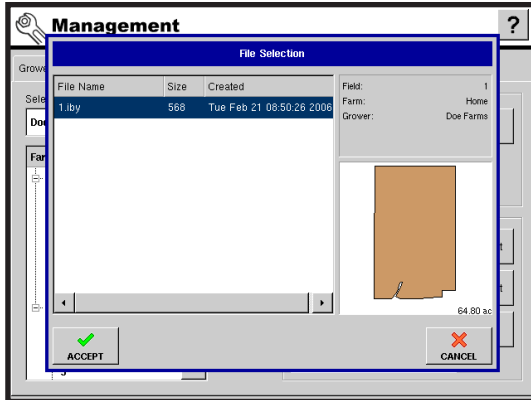

To import a boundary from the external data card, highlight the correct field in the Farm/Field list.

Press **Import**, select the desired file.

Press **Accept** to complete the import process.

#### Boundary Export

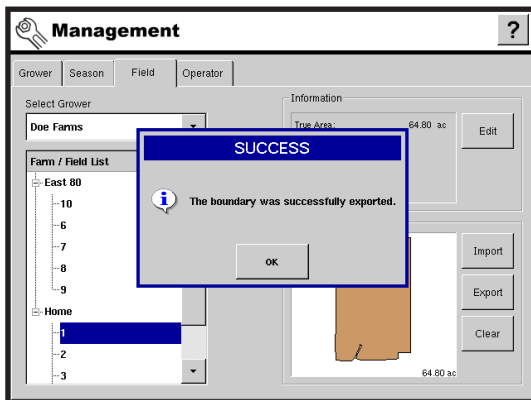

If you would like to export a boundary to the external data card highlight the correct field in the Farm/Field list. Then press the export button. A window will appear telling you that the boundary was exported successfully.

Press **OK** to return to the field setup screen.

## OPERATOR SETUP SCREEN

A machine operator must be selected at initial startup of the KINZE Vision display and can be changed as needed from the Home screen.

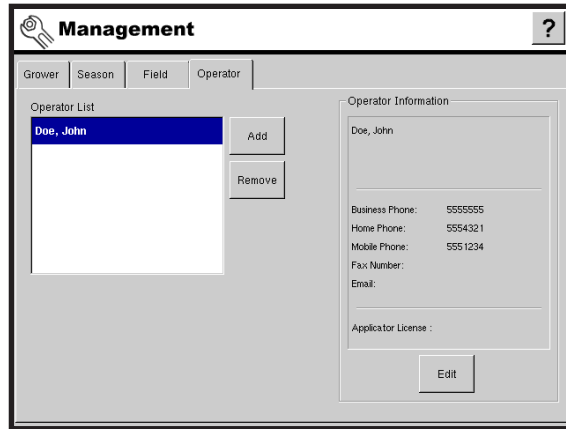

**Operator Setup Screen**

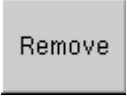
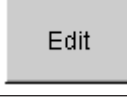
Item	Description
<b>Operator List</b>	Displays a list of all machine operators configured within the KINZE Vision display.
	Press to add a new machine operator. The first and last name of any people entered into the system as contact information for a business or grower will be made available for selection from a list. New people can be added to the system by following the setup wizard steps. For more information, see <i>“Adding A New Operator ” on page 4-25.</i>
	Press to remove the selected entry from the Operator List.
<b>Operator Information Frame</b>	Displays all information stored within the system for the selected entry in the Operator List.
	Press to edit any information stored for a selected operator. For more information, see <i>“Adding Or Editing Operator Personal Information ” on page 4-26.</i>

## ADDING A NEW OPERATOR

New Operators are added to the system by following the process outlined below.

### STEP 1 Business/Person Setup

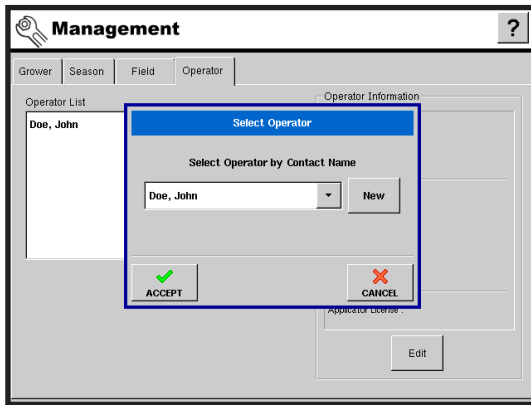

After pressing the **Add** button on the Operator screen, the Select Operator dialog is shown. The drop down list box displays all people setup within the system and makes them available for selection as an Operator.

If the Operator is not present in the system as a business or farm contact, press the **New** button to start the process of adding Operator information.

### STEP 2 Business/Person Setup

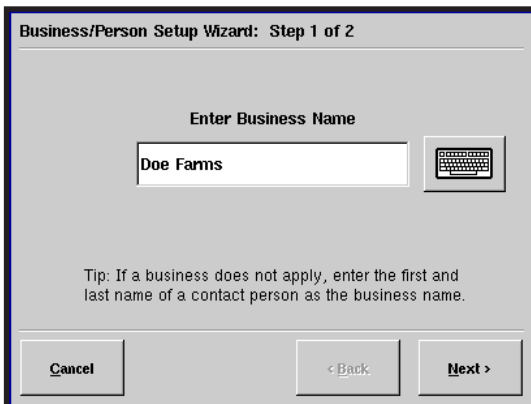

Because Operators are directly related to a Business or Farm owner, the first step of the setup process asks that a Business Name be entered into the system.

**NOTE: For situations where the Operator is not the primary owner of an existing business or farm, it is recommended that the person's first and last name be entered as a Business Name.**

After entering the Business Name into the system, press **Next** to proceed to the final step in the setup process.

### STEP 3 Business/Person Setup

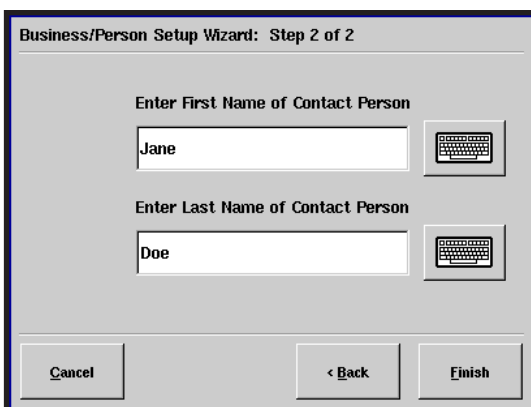

Enter the first and last name for the Operator and press **Finish** to complete the new Operator setup process.

## ADDING OR EDITING OPERATOR PERSONAL INFORMATION

### STEP 1 Accessing the Edit Screen

The screenshot shows a software interface titled "Management" with a help icon and a question mark. Below the title are tabs for "Grower", "Season", "Field", and "Operator". The "Operator" tab is selected. On the left, the "Operator List" contains one entry: "Doe, John", which is highlighted in blue. To the right of the list are "Add" and "Remove" buttons. On the right side of the screen is the "Operator Information" form, which displays the details for "Doe, John": Business Phone: 5555555, Home Phone: 5554321, Mobile Phone: 5551234, Fax Number: (blank), Email: (blank), and Applicator License: (blank). An "Edit" button is located at the bottom of this form.

Select an Operator from the Operator List and press the **Edit** button to enter or edit any of the data displayed in the Operator Information frame.

### STEP 2 Personal Information Data Entry

The screenshot shows a "Personal Information" form with a blue header. The form is divided into two columns of input fields. The left column contains: Business Name (John Doe), Business Phone (5555555), Fax (blank), Address (Any where), City (Any town), State/Province (Any state), Postal Code (blank), Country (blank), and Memo (blank). The right column contains: First Name (John), Last Name (Doe), Applicator License (blank), Home Phone (5554321), Mobile Phone (5551234), and Email (blank). At the bottom center of the form is a green checkmark icon with the text "OK" below it.

After pressing the desired control button, the on-screen keyboard or numeric keypad will be shown to allow data entry into the system. Press **OK** to complete the edit process.



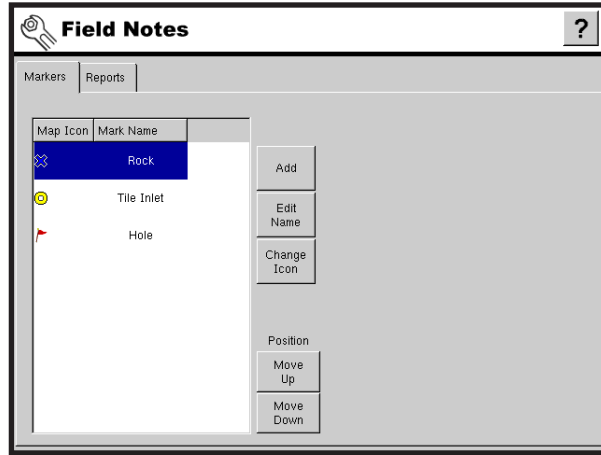

**NOTE: Information on the screen can be added or edited at any time.**

## FIELD NOTES SETUP SCREEN

Markers are a collection of point objects that are available on the Field Notes tab of the run screen. As the name suggests, markers allow mapping points on-the-go to identify specific features within a field.

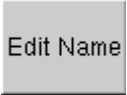

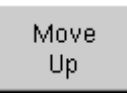
**Markers Setup Screen**

Item	Description
<b>Markers List</b>	Displays all Markers and the icon in use for each Marker.
	Press to display the keyboard screen to create and name a new marker. For more information, see <i>“Creating a New Marker ” on page 4-28.</i>
	Press to display the keyboard screen to edit the name of any selected marker. For more information, see <i>“Editing A Marker Name ” on page 4-29.</i>
	Press to change the icon of any selected marker. For more information, see <i>“Changing A Marker Icon ” on page 4-30.</i>
	Press to move a selected marker up one position in the markers list. This also changes the order in which the Markers are displayed on the Run screen.
	Press to move a selected marker down one position in the markers list. This also changes the order in which the Markers are displayed on the Run screen.

## CREATING A NEW MARKER

The steps below outline the process of setting up Markers within the KINZE Vision display.

### No Markers

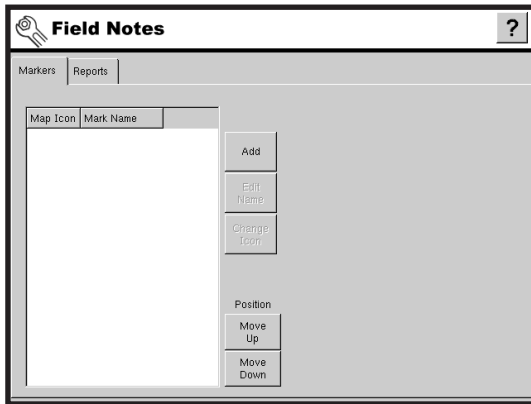

Field Notes screen prior to any markers being configured.

### Adding A Marker

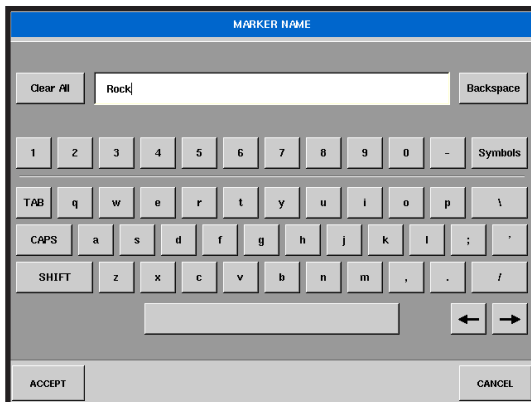

Press the **ADD** button on the Field Notes setup screen to launch the on-screen keyboard. Enter any combination of letters, numbers, and symbols up to 10 characters long to be used as the name for the new Marker. Press the **ACCEPT** button to finish adding the Marker to the system.

### New Marker Added

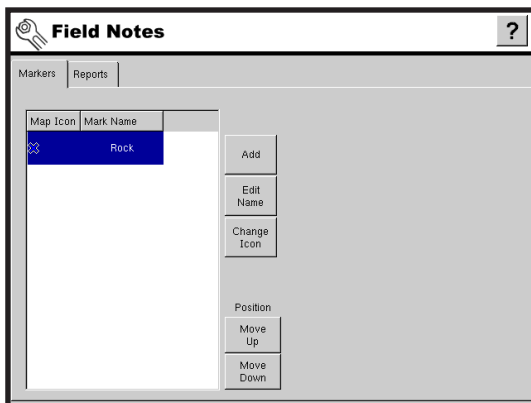

Field Notes setup screen after adding a Marker named "Rock".

## EDITING A MARKER NAME

The process of renaming a Field Notes Marker is outlined in the steps below.

### Existing Marker Name

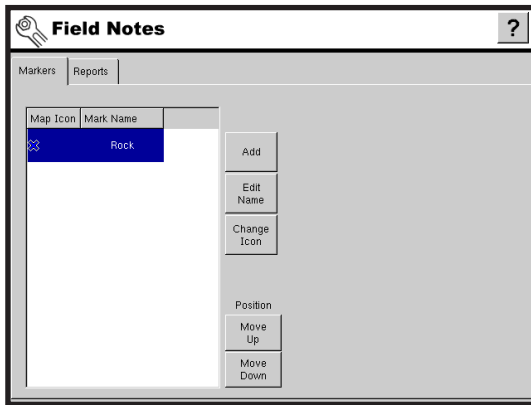

Field Notes screen with an existing Marker named “Rock”. Select “Rock” from the list box and press the **EDIT NAME** button to rename the Marker.

### Edit Marker Name

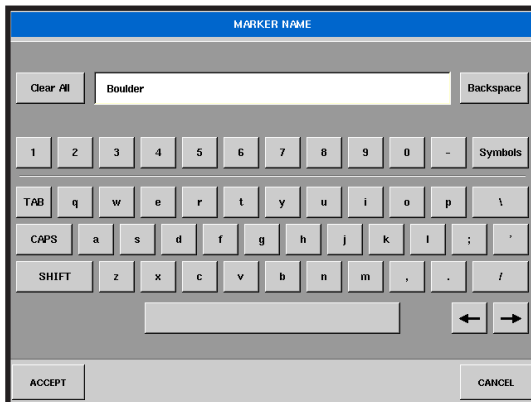

Enter the new name for the existing Marker, press **ACCEPT** to save the change.

### New Marker Name

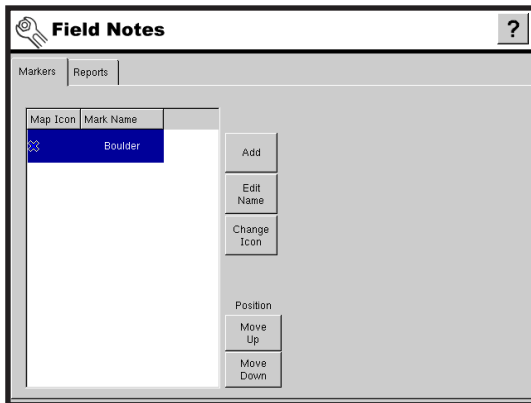

Field Notes screen with Marker renamed to “Boulder”.

## CHANGING A MARKER ICON

**X** is the default icon assigned by the system for all new Markers. A different icon can be assigned to a Marker by following the steps outlined below.

### Select Marker To Edit

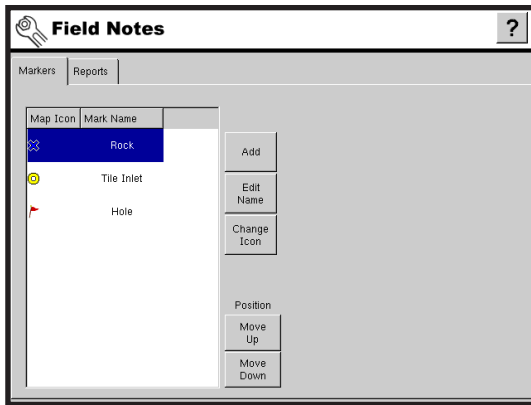

To change the icon for a Marker, select the desired Marker from the list and press the **CHANGE ICON** button.

### Select New Icon

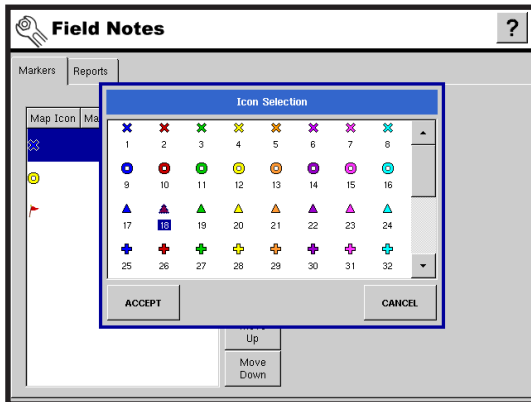

Select the desired icon from the list and press **ACCEPT** to save the change.

### Setup Screen With New Marker

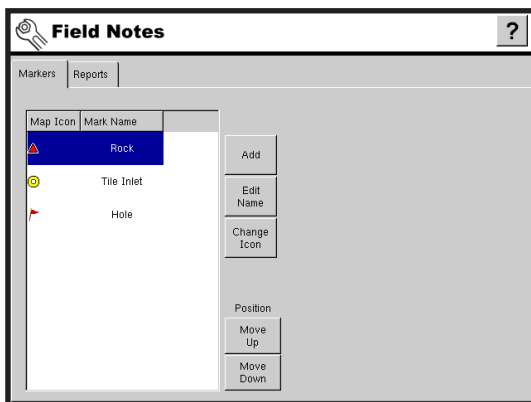

Field Notes setup after changing the rock icon.

## APPLICATION OPERATION REPORT SETTINGS

The settings and options contained on the Reports tab of the Field Notes configuration settings determine the behavior of the KINZE Vision display at the Run Screen during the process of creating application reports. Brief descriptions of these settings are outlined in the following table.

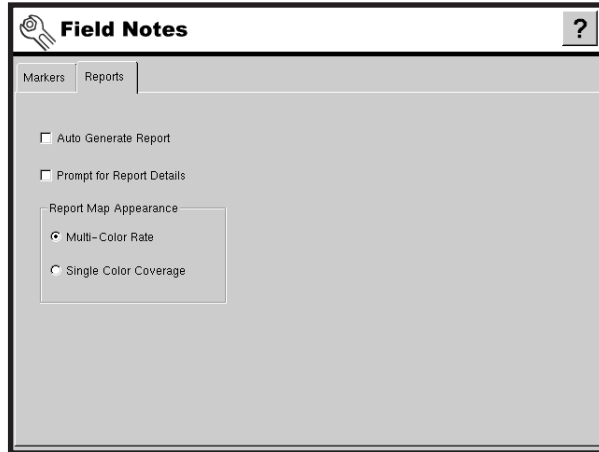

**Application Report Settings And Options**

Report Option Setting	Description
<b>Auto Generate Report</b>	Check this option to have the KINZE Vision display automatically generate an application report each time product application is completed and the <b>FIELD</b> button is selected.
<b>Prompt For Report Details</b>	Check this option to have the KINZE Vision display automatically launch the region summary data collection dialog each time a new region is created at the run screen during application rate control.
<b>Report Map Appearance</b>	<ul style="list-style-type: none"> <li>• <b>Multi-Color Rate</b> - Select this option to have application reports display the application maps using rate legend as displayed on the Run screen.</li> <li>• <b>Single Color Coverage</b> - Select this option to have the application reports display single color product coverage maps.</li> </ul>

## PRODUCT APPLICATION SMART REPORT™

The KINZE Vision Smart Report™ provides the user with a simple method to create printed documentation of all in-field product application events. Content of each Smart Report is appropriate to the product and equipment used during that specific application event.

### Smart Report File Format

Product application reports are created in Adobe Acrobat® PDF file format. The Adobe Reader® software required to view and print application reports comes pre-installed on most computers. If Adobe Reader® is not installed on your computer, the program is available for download at no charge.

### Smart Report File Storage

Product application reports are automatically stored on the external data card at the time of report creation. Reports are named using the following information provided in the KINZE Vision display:

- Serial Number
- Grower
- Farm
- Field Name
- Configuration Name
- Unique ID #
- Date Of Most Recent Product Application

### Viewing Reports: Setup / Console / Memory

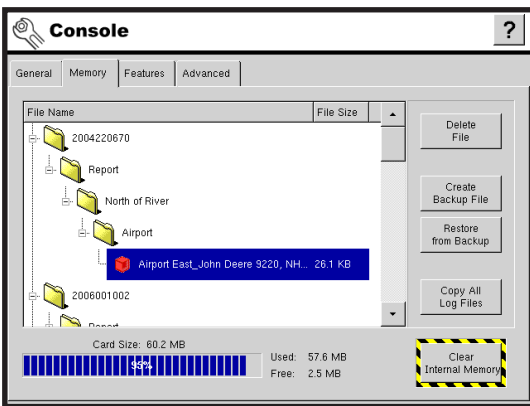

A file browser is located on the Memory tab of Console Setup. Folders and files can be deleted from the storage card by using the **Delete File** function at this screen.

**IMPORTANT: Appropriate warnings are given by the system prior to the files being deleted from the storage card. Deleted data cannot be recovered from the card.**

All application reports are stored in a common folder named **Report** on the root of the external storage card.

Sub-folders are automatically created as needed for each grower and field as reports are created.

## Control Channel Report Content

The content of all KINZE Vision product application reports is divided into two distinct groups. The first page(s) of the report represent field and product control channel specific information. In cases of multiple product application, multiple pages will be generated, one for each channel of product control.

## Control Channel Content



**Any Business**  
Any Town, Any State, 55555  
(555) 555-5555

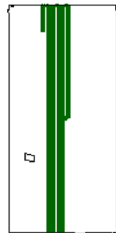

**KINZE**  
APPLICATION REPORT

<b>Grower</b>		<b>Field</b>			
Any Business Any Town, Any State, 55555 (555) 555-5555		Name: South 91      Description: SE corner of section County: Any County Township: Any Township Range: Any Range Section: Any Section			
<b>Equipment Configuration</b>		<b>Application</b>			
Vehicle: Generic Sprayer Implement: Generic Sprayer Boom Height: Not Observed		Timing: Not Observed Placement: Not Observed Nozzle PN: Not Observed Boom Pressure: Not Observed			
		<b>Application Date/Time</b>			
		Start Time: 01/12/2008 3:40 PM End Time: 01/12/2008 4:08 PM			
<b>Product: Brand A</b>					
Applied Area: 8.35 ac					
<div style="display: flex;"> <div style="flex: 1;"> <p>Rate (fl oz):</p> <ul style="list-style-type: none"> <li><span style="display: inline-block; width: 10px; height: 10px; background-color: #008000; margin-right: 5px;"></span> 205 +</li> <li><span style="display: inline-block; width: 10px; height: 10px; background-color: #008000; margin-right: 5px;"></span> 185 - 205</li> <li><span style="display: inline-block; width: 10px; height: 10px; background-color: #008000; margin-right: 5px;"></span> 165 - 185</li> <li><span style="display: inline-block; width: 10px; height: 10px; background-color: #008000; margin-right: 5px;"></span> 145 - 165</li> <li><span style="display: inline-block; width: 10px; height: 10px; background-color: #008000; margin-right: 5px;"></span> 0 - 145</li> </ul> </div> <div style="flex: 2; text-align: center;">  </div> </div>					
Total Field Area: 75.33 ac					
<b>Crop</b>		<b>Restrictions</b>			
Crop: Not Observed Growth Stage: Not Observed		Crop Rotation Restrictions: Not Observed Restricted Entry Interval (REI): Not Observed			
		<b>Target Pests</b>			
		Not Observed      Not Observed Not Observed      Not Observed			
<b>Product Summary</b>					
<b>Name</b>	<b>Manufacturer</b>	<b>EPA #</b>	<b>RUP</b>	<b>Amount</b>	<b>Average Rate</b>
Brand A		9788900	No	36238.47 fl oz	4339.33 fl oz/ac
<b>Operator/Supervisor Information</b>					
Operator: Jim Smith      License:				Signature	
Operator:      License:					
Supervisor:      License:					

South 91\_Generic Sprayer, DirectLiquid\_00000227\_080112.pdf Page 1 of 2

- Service Provider Information
- Grower Information
- Field Information
- Equipment Configuration Information
- Application Information
- Date/Time Information
- Crop Information
- Crop Rotation Restrictions
- Restricted Entry Interval (REI)
- Multiple Target Pests
- Applied Product Information
- Operator and Supervisor Information

## Regional Summary Report Content

The last pages of the application report contain field region summary data. Multiple regions can be created as needed in each field. Each region can document changes in weather and other critical information. The user has the ability to log changes in temperature, weather and machine operators simply by creating a new field region. Additional regional summary pages are created as needed if more than two field regions are created for an individual field.

### Regional Summary Information

REGION SUMMARY		
Item	Region 1	Region 2
Region Name	<1>	<2>
Operator Name	Jim Smith	Jim Smith
<b>Application Details</b>		
Area	70.63 ac	24.06 ac
Harness 10 GPA Amount	706.64 gal	240.95 gal
Application Start Time	03/03/2008 1:18 PM	03/03/2008 2:26 PM
Application End Time	03/03/2008 2:26 PM	03/03/2008 2:53 PM
<b>Soil Conditions</b>		
Soil Temperature	60 ° F	60 ° F
Soil Moisture Level	Dry	Dry
Soil Condition	Medium	Medium
Crop Residue Level	High	High
Tillage Type	No Till	No Till
<b>Environmental</b>		
Air Temperature	68 ° F	56 ° F
Wind Speed	10 mph	12 mph
Wind Direction (From)	E	N
Sky Condition	Partly Cloudy	Cloudy
Humidity	35 %	35 %
<b>Additional Information</b>		
Memo		Cold front and rain moving in from the north.

Filename: South 91\_Post Sprayer, DirectLiquid\_0000178c\_060303.pdf Page 2 of 2

- Region Name
- Machine Operator By Region
- Applied Area
- Applied Volume
- Application Start/Stop Time and Date
- Soil Condition Information
- Environmental Information
- Region Text Memo

## GENERAL CONSOLE SETUP TAB

The General Tab contains settings related to time, date, and KINZE Vision display owner information.

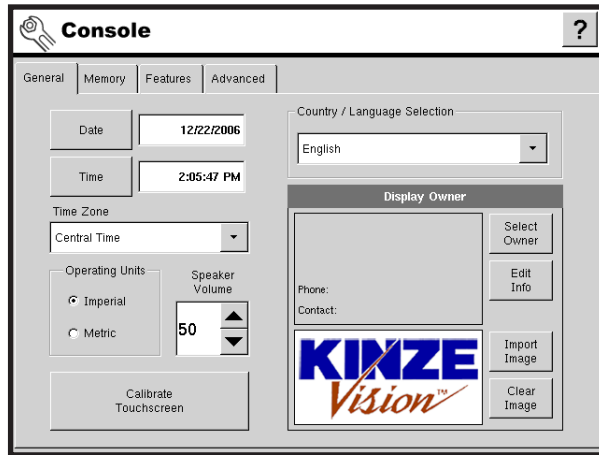

**Console Setup Screen**

Date	Press to set current date.
Time	Press to set current time.
<b>Time Zone</b>	Select the correct time zone for your area from the drop down list box.
<b>Operating Units</b>	Select between using Imperial or Metric units for calibration and control units.
<b>Speaker Volume</b>	Press the arrows to set the volume of on-board speaker.
Calibrate Touchscreen	Press to launch the touch screen calibration wizard. For more information on calibrating the touch screen, see <i>"TouchScreen Calibration"</i> on page 4-36.
<b>Display Owner</b>	This area of the display contains functionality for setting up a Display Owner and making any needed edits to the owner personal information. The Display Owner information is used in the product application report feature of application rate control. An image for the Display Owner can be imported for inclusion on product application reports. For more information on the Display Owner Setup, see <i>"Display Owner Setup"</i> on page 4-37.

## TOUCHSCREEN CALIBRATION

Do not use any sharp objects to operate the touch screen or the display may be damaged.

### Confirm Touchscreen Calibration

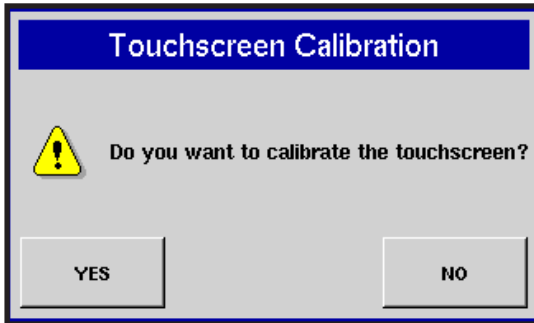

Press **YES** to confirm the start of the touchscreen calibration process.

### Calibration Wizard

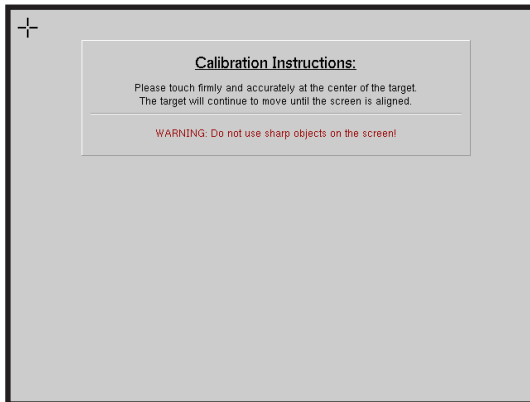





Calibrate the touchscreen following the on-screen instructions.

DISPLAY OWNER SETUP

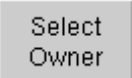

Display Owner Setup

Item	Description
	Press to display a list of all farm and business contacts set up in the system. The on-screen dialog that is displayed will give options to select an existing person/business or create a new one to be used as the Display Owner.
	Press this button to edit or add the personal information for the Display Owner.
	Press to import the image file that is displayed with the Display Owner information on any application reports that are created. The system currently supports .BMP and .PNG file formats. Size is limited to a maximum of 200 pixels wide x 100 pixels tall. For more information, see <i>"Display Owner Image Import"</i> on page 4-38.
	Press to delete the Business Owner image.

## Display Owner Image Import

Follow the steps outlined below to import a Display Owner image.

### Before Image Import

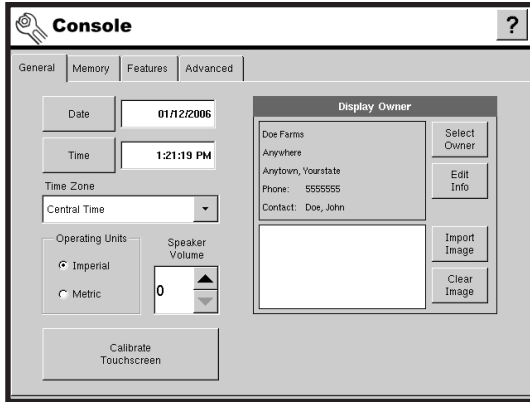

Console General setup screen prior to a Display Owner image being imported.

### Image File Selection

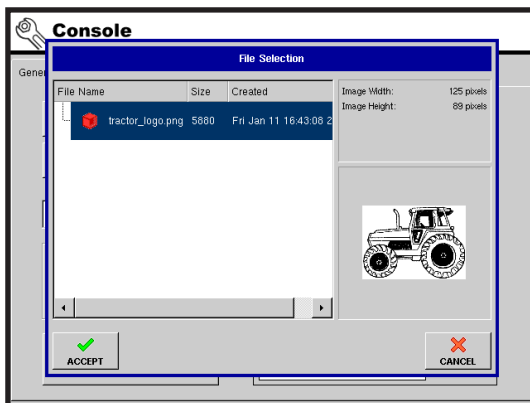

After pressing the **Import Image** button the dialog at the left is displayed to allow the selection of a file to import. Press the **ACCEPT** button to import the selected file.

### After Image Import

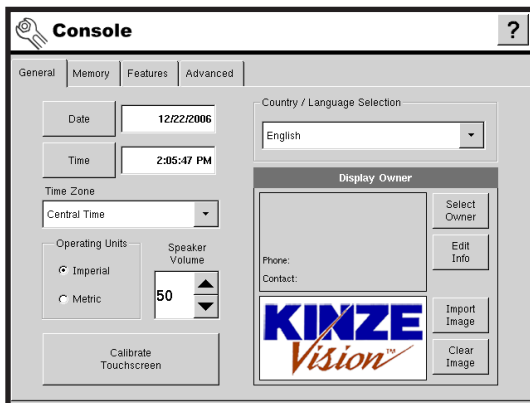



Console General setup screen after importing a Display Owner image.

## CONSOLE SETUP MEMORY TAB

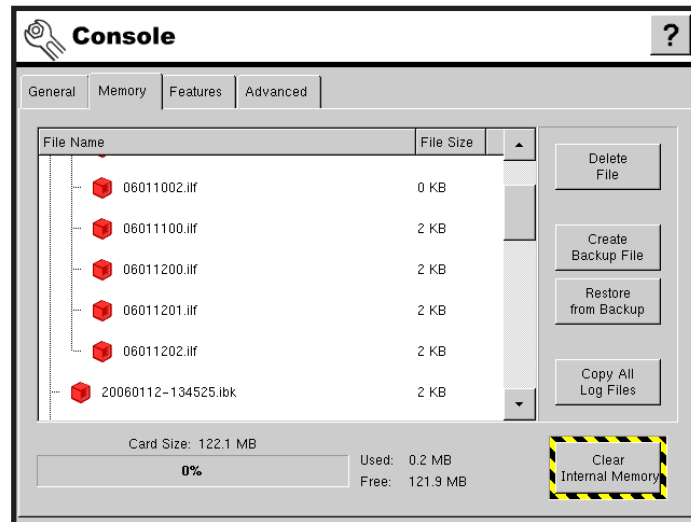
### Card Management Features

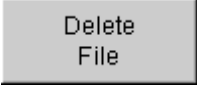
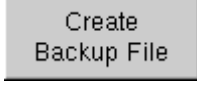
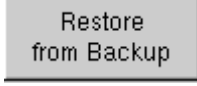
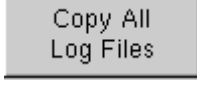

**Memory Card Management Window**

Setting	Description
	Press to delete a selected file from the external memory card.
	Press to create a backup file of all configuration settings, products, and Grower-Field Management data structure on the external memory card. Backup files are stored using the <b>.ibk</b> file format.
	Press to restore a backup file from the external data card to the internal memory of the KINZE Vision display.
	Press to copy all logged data to the external memory card. Log files are stored using the <b>.ilf</b> file format.
	Press this button to clear the internal memory of the display. The system will present a warning dialog box and ask if you would like to create a backup file prior to clearing the memory.  <b>IMPORTANT: The KINZE Vision display will be returned to “new out of box” unconfigured state when the memory is cleared.</b>

## CONSOLE FEATURES

### Enabling Console Features

#### Unlocking Features

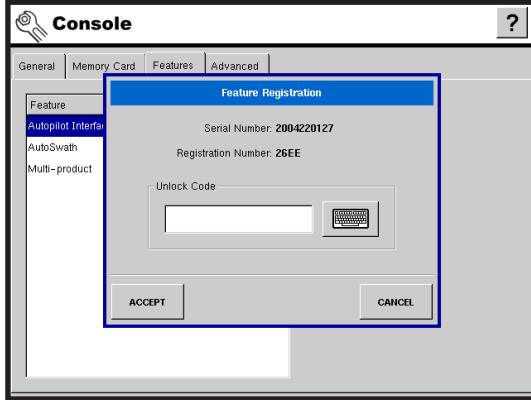

**NOTE:** Unlock codes are unique to the serial number of each KINZE Vision display and the feature registration number.

## ADVANCED

### Advanced Console Settings

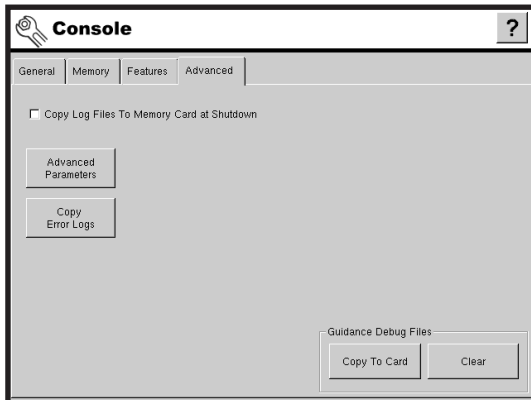

**IMPORTANT:** All functionality on the Advanced tab is reserved for use by KINZE Engineering. **DO NOT** change any setting on this page without specific instruction from KINZE.

## GPSOT SETUP PAGES

The GPS settings only apply to KINZE Vision displays connected to one of the approved TSIP receiver/lightbar combinations.

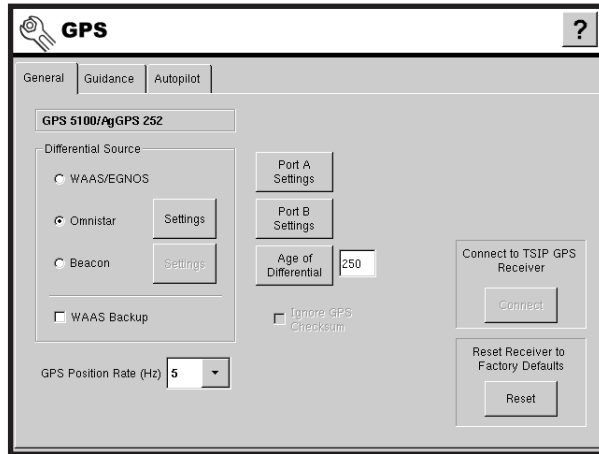

**GPS General, Guidance Configuration Tabs**

## FURTHER GPS REFERENCES

For detailed information, see the following:

- *“GPS General Setup Tab ” on page 4-42*
- *“GPS Serial Port” on page 4-44*
- *“Satellite Differential Setup ” on page 4-46*
- *“Beacon Differential Setup ” on page 4-48*
- *“GPS Guidance Tab ” on page 4-49*
- *“GPS General Tab ” on page 4-56*
- *“GPS Advanced Tab ” on page 4-57*
- *“TSIP Receiver Tab ” on page 4-59*
- *“Omnistar® Tab ” on page 4-60*

## GPS GENERAL SETUP TAB

General GPS settings relate to choosing differential source and NMEA messages output by the TSIP receiver. Details are explained below.

- For more information on other tabs which may appear on the GPS screen next to the **General** tab, see “*GPS General Tab*” on page 4-56.
- For a GPS/Guidance Menu, see “*GPS/Guidance Menu Tree*” on page 7-4.

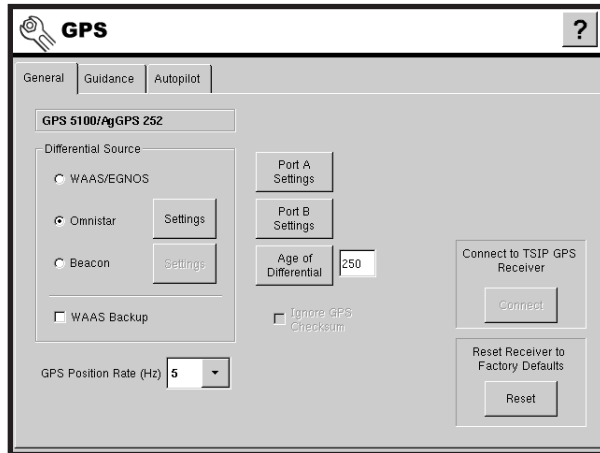

**GPS General Setup Tab**

Setting	Description
<b>GPS Receiver Box</b>	Displays the name of your GPS Receiver on the upper L.H. side of the GPS window. GPS receivers that could be used include the KINZE GPS 1500, Ag Leader GPS 5100 or Trimble AgGPS 252.
<b>Differential Source</b>	Select choice of WAAS/EGNOS, Satellite (OmniSTAR®) or Beacon (Coast Guard) differential sources.
<b>WAAS Backup</b>	Check the <b>WAAS Backup</b> selection if using Satellite or Beacon differential and you want the receiver to automatically switch to WAAS in case of signal loss from the primary differential source.
<b>GPS Position Rate (Hz)</b>	The GPS Position Rate drop down menu represents the cycles per second that the display receives guidance information from viewable satellites. You can select <b>1 Hz, 2 Hz, 4 Hz, 5 Hz</b> or <b>10 Hz</b> from the drop-down menu.  <b>NOTE: A minimum selection of 5 Hz is required for row clutch control.</b>
<div data-bbox="167 1549 383 1667" style="border: 1px solid gray; padding: 5px; margin-bottom: 10px; text-align: center;">Port A Settings</div> <div data-bbox="167 1703 383 1820" style="border: 1px solid gray; padding: 5px; text-align: center;">Port B Settings</div>	These represent two physical, parallel ports that are located on the receiver. Both of these ports can individually configured to serve a variety of different functions. For more information, see “ <i>GPS Serial Port</i> ” on page 4-44.

## GPS GENERAL SETUP TAB (Continued)

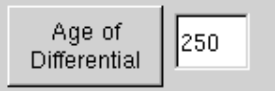
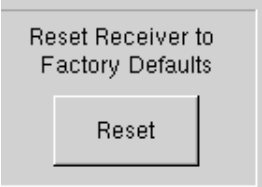
Setting	Description
	<p>Displays the elapsed time since reception of last differential correction signal.</p> <p><b>NOTE: The Age of Differential button is only functional when GPS is connected.</b></p>
<p><b>Ignore GPS Checksum</b></p>	<p>Check this to ignore intermittent GPS message errors.</p>
<p><b>Connect to TSIP GPS Receiver</b></p>	<p>Forcibly connects to TSIP GPS receiver. Pressing this button will force the port to TSIP communication.</p> <p><b>NOTE: This button is functional only if the TSIP GPS receiver is physically connected.</b></p>
	<p>Press the <b>Reset</b> button to restore TSIP receiver settings to the factory default. This will remove all custom TSIP settings.</p> <p><b>NOTE: Differential settings and NMEA messages will need to be configured for the system to function properly after resetting factory defaults.</b></p>

## SERIAL PORT SETTINGS

To view the Serial Port Settings window, go to the GPS screen and press the buttons labeled **Port A Settings** or **Port B Settings**.

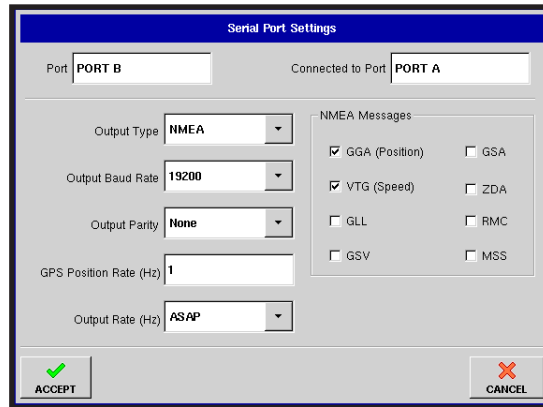

**Serial Port Settings Window**

Setting Description	Description
<b>Port</b>	Indicates the physical (secondary) port that you are configuring.
<b>Connected To Port</b>	Indicates the physical port to which you are connected.
<b>Output Type</b>	Displays what type of protocol the receiver is using. (NMEA, TSIP or Lightbar).
<b>Output Baud Rate</b>	Displays the speed at which the receiver communicates with the display. Some common Baud rates include: <b>4800</b> - Used by most yield monitors. <b>19200</b> and <b>38400</b> - Used by DirectCommand™. <b>NOTE: A selection of 19200 is required for row clutch control.</b>
<b>Output Parity</b>	Displays either <b>Odd</b> or <b>None</b> . If using TSIP, this setting should be <b>Odd</b> . If using NMEA, this setting should be <b>None</b> . <b>NOTE: Parity refers to a technique for checking data integrity after transmission.</b>
<b>GPS Position Rate (Hz)</b>	Represents the cycles per second (shown in Hz) that the display receives position information from viewable satellites. (This is the same number as shown on GPS Position Rate drop down list menu located on the <b>General</b> tab).
<b>Output Rate (Hz)</b>	Represents the cyclical rate (in Hz) at which the receiver sends information to the KINZE Vision display. This field shows a value of either <b>1</b> or <b>ASAP</b> . The default rate is <b>1 Hz</b> . <b>ASAP</b> represents a Hz value of more than 1.

## SERIAL PORT SETTINGS (Continued)

Setting	Description
<b>NMEA Messages</b>	<p>These check boxes represent various communication protocols or formats that have been set by the National Marine Electronics Association (NMEA) and used in information “strings” or sentences output by the GPS Receiver. At present, the KINZE Vision display only uses two NMEA Message formats: GGA and VTG.</p> <ul style="list-style-type: none"><li>• <b>GGA</b> - This NMEA message format is the data fix that establishes your position in longitude and latitude.</li><li>• <b>VTG</b> - This NMEA message format stands for ground speed (velocity) in area over distance</li><li>• <b>GLL, GSV, GSA, ZDA, RMC, MSS</b> - Leave these other NMEA message formats unchecked, unless you are connected to a third-party monitor and have been directed to do so.</li></ul>

## SATELLITE DIFFERENTIAL SETUP

The use of satellite differential requires purchase of a subscription from OmniSTAR®. Settings related to using satellite differential correction vary based upon your geographic location. Setup details are explained in the following table. More specific information can be obtained by contacting OmniSTAR.

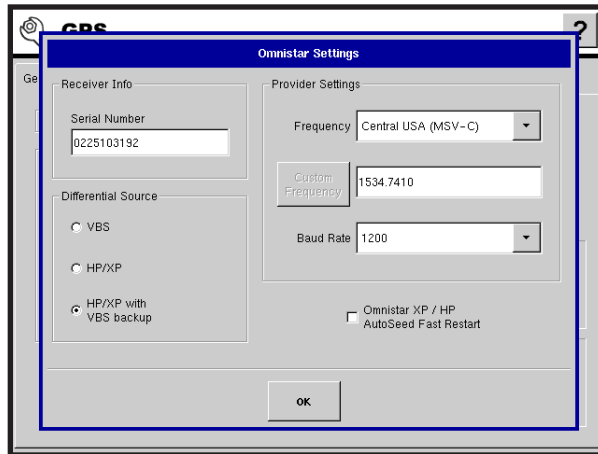

**OmniSTAR® Settings Window**

Setting	Description
<b>Receiver Serial Number</b>	This box shows the serial number of your receiver.  <b>NOTE: You will need to know this serial number when contacting OmniSTAR in order to set up the receiver.</b>
<b>Differential Source</b>	The choices include VBS, HP/XP, and HP/XP with VBS backup. These three options are described below:  <b>VBS</b> - OmniSTAR® <b>VBS</b> (Virtual Base Station) is a “sub-meter” level of service.  <b>XP</b> - The OmniSTAR® <b>XP</b> service is more accurate than VBS, but slightly less accurate than HP. It provides short-term accuracy of a few inches and long term repeatability of better than 20 centimeters.  <b>HP/XP</b> - The OmniSTAR® <b>HP</b> (High Performance) service is the most accurate of the three options.  <b>HP/XP with VBS backup</b> - If this option is chosen, and you lose your HP/XP signal, your receiver will automatically switch to VBS.
<b>Frequency</b>	In the <b>Frequency</b> drop down list box, select the geographic region where you are located. In the example above, the Central USA has been selected. If you wish to enter a Custom Frequency, select Custom, located at the bottom of this drop down list box.

## SATELLITE DIFFERENTIAL SETUP (Continued)

Setting	Description
<b>Custom Frequency</b>	<p>If you wish to enter a Custom Frequency, select Custom from the <b>Frequency</b> drop down list box. Then enter the frequency number in the text box below.</p> <p><b>NOTE: KINZE does not provide custom frequency numbers. Enter a number only if directed to by OmniSTAR®.</b></p>
<b>Baud Rate</b>	<p>The baud rate represents the speed at which your receiver obtains information from the satellite.</p> <p><b>NOTE: Although three different baud rates are shown in this list, you should always keep the baud rate set at 1200.</b></p>
<b>OmniSTAR® XP/HP AutoSeed™ Fast Restart</b>	<p>Checking this box before the vehicle is shut down allows the receiver to utilize shutdown time to acquire the appropriate satellites in order to ensure a quick and efficient startup. This reduces the time taken for satellite convergence after startup, and thus increases accuracy in the field.</p> <p><b>NOTE: To get the most benefit from AutoSeed technology, you should shut down the vehicle in a place where the receiver has a clear view of the sky. Do not move the vehicle before powering up again.</b></p>

### OmniSTAR® Contact Information

The table below contains contact information for OmniSTAR® for all locations in the world. A map of these service regions can be found at [www.Omnistar.com](http://www.Omnistar.com).

OmniSTAR® Service Region	Contact Information
North and South America	1-888-883-8476 1-713-785-5850
Europe and North Africa	31-70-317-0900
Australia and Asia	61-8-9322-5295
Southern Africa	27-21-552-0535

## BEACON DIFFERENTIAL SETUP

The Beacon settings window is where you can enter settings for a Coast Guard Beacon differential correction source. This signal is ground-based and generally available throughout the United States, but may be limited in some areas. The signal is free, but requires a Beacon-capable receiver.

There are three different methods of determining the specific Beacon tower that the GPS system uses for differential corrections: **Auto Range**, **Auto Power** and **Manual**. The details of these settings are outlined in the following table.

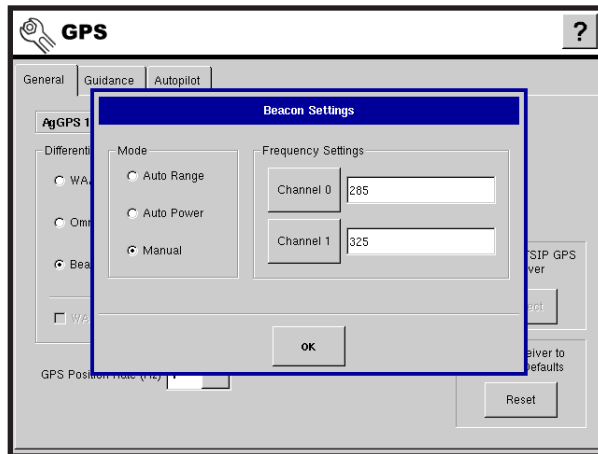

**Beacon Settings Window**

Setting	Description
<p><b>Mode</b></p>	<p>Determines what method the GPS receiver uses to select a Beacon tower location and differential signal.</p> <p><b>Auto Range</b> - Uses the frequency for the closest Beacon differential tower.  <b>Auto Power</b> - Uses the strongest available Beacon differential signal.  <b>Manual</b> - Uses the manually-configured Beacon Frequency Settings</p>
<p><b>Frequency Settings</b></p>	<p>Enter frequencies for use with <b>Manual</b> mode selection. Frequency settings for Channel 0 and Channel 1 can range between <b>283.5</b> and <b>325.0</b>.</p> <p><b>NOTE: Call KINZE Service Department, through you local KINZE Dealer, if you have questions about changing frequencies in manual mode.</b></p>

## GPS GUIDANCE TAB

The Guidance Tab, located on the **GPS** screen includes some general settings for the External Lightbar feature. For a menu detailing GPS Guidance Settings, see “GPS/Guidance Menu Tree” on page 7-4.

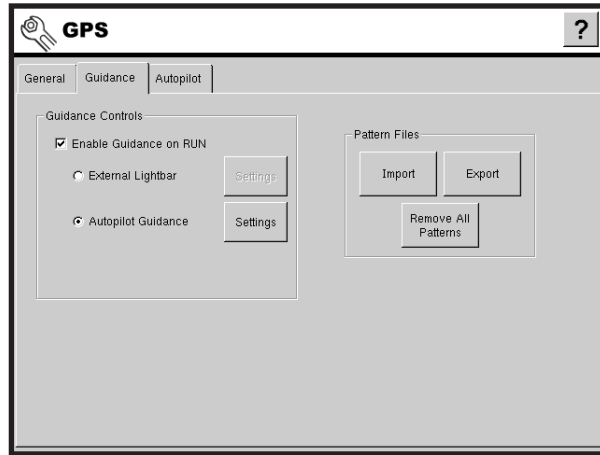



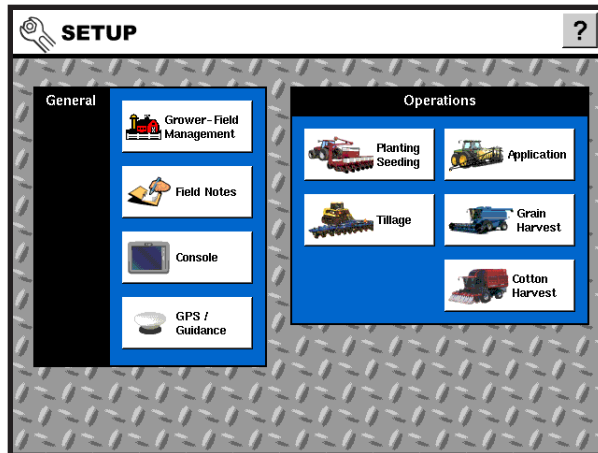

**GPS Guidance Tab**

Setting	Description
<b>Guidance Controls</b>	The Guidance Controls area of the Guidance Tab includes information specific to the external lightbar guidance.
<b>Enable Guidance On Run</b>	Checking this box allows you to use the settings shown on the Autopilot tab on the Run screen.
<b>External Lightbar Option Button</b>	Press this option button if you wish to use a lightbar with the KINZE Vision display.
<b>Pattern Files</b>	The Pattern Files area of the Guidance Tab allows you to move .pat (pattern) files between the KINZE Vision display and the compact flash card.

## OPERATIONS SETUP BASICS



**Main Setup Screen**

Item	Description
	Press to access setup of planter logging, mapping, and population control configurations. For more information, see <i>“Planting And Seeding Setup ”</i> on page 4-51.
	Press to access setup of tillage operation mapping configurations. For more information, see <i>“Tillage Operation Setup ”</i> on page 4-52.
	Press to access setup of product application logging, mapping, and rate control configurations. For more information, see <i>“Application Setup ”</i> on page 4-53.
	Press to access setup of Grain Harvest yield monitoring configurations. For more information, see <i>“Grain Harvest Yield Monitoring Setup ”</i> on page 4-54.
	Press to access setup of Cotton Harvest yield monitoring configurations. For more information, see <i>“Cotton Harvest Yield Monitoring Setup ”</i> on page 4-55.

## PLANTING AND SEEDING SETUP

The Planting setup screens contain all the necessary settings to configure the system for logging, mapping, and population control of all supported planting operations. For more information, see “Planting Setup Tabs” on page 5-1.

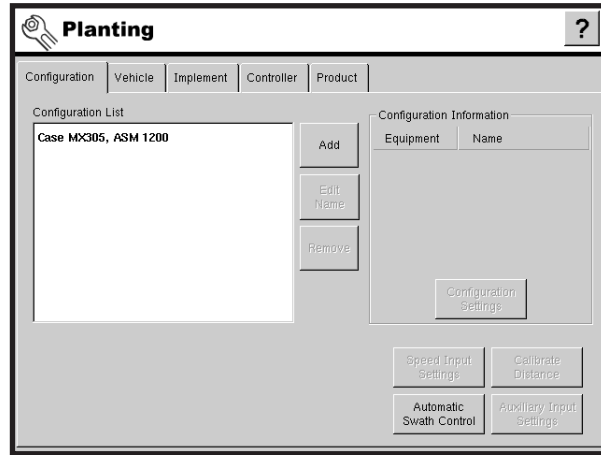

**Planting And Seeding - Prior To Configuration**

Item	Description
<b>Configuration</b>	Add and edit operating configurations. Operating configurations are a combination of Vehicle, Implement, and Controller.  Configuration examples: <ul style="list-style-type: none"> <li>• Tractor and planter mapping seed varieties</li> <li>• Tractor and planter using seed population control</li> </ul>
<b>Vehicle</b>	Add and edit vehicle configurations. Settings include GPS offsets of rear axle and implement mounts in relation to GPS antenna.
<b>Implement</b>	Add and edit implement configurations. Settings include locations for product dispense and swath locations in relation to GPS antenna and vehicle hitch.
<b>Controller</b>	Add and edit product population rate control channels.
<b>Product</b>	Add and edit seed type and varieties.

## TILLAGE OPERATION SETUP

The Tillage setup screens contain all the necessary settings to configure the system for mapping tillage operations.

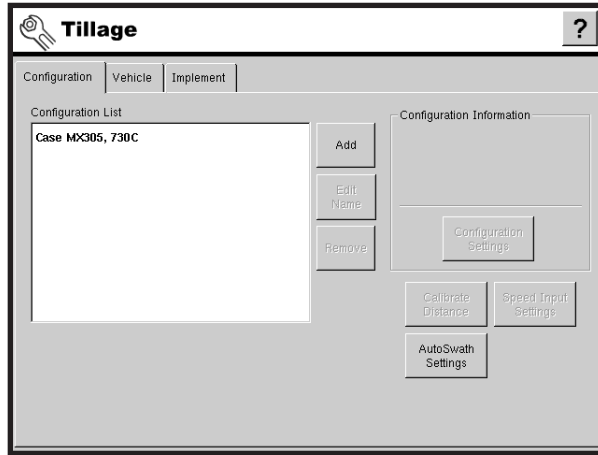

**Tillage Setup - Prior To Configuration**

Item	Description
<p><b>Configuration</b></p>	<p>Add and edit operating configurations. Operating configurations are a combination of Vehicle, and Implement.</p> <p>Configuration examples:</p> <ul style="list-style-type: none"> <li>• Tractor with pull-type field cultivator.</li> <li>• Tractor with mounted cultivator</li> <li>• Tractor with mounted chisel plow</li> </ul>
<p><b>Vehicle</b></p>	<p>Add and edit vehicle configurations. Settings include GPS offsets of rear axle and implement mounts in relation to GPS antenna.</p>
<p><b>Implement</b></p>	<p>Add and edit implement configurations. Settings include locations for tillage point in relation to GPS antenna and vehicle hitch.</p>

## APPLICATION SETUP

The Application setup pages contain all the necessary settings to configure the system for logging, mapping, and rate control of supported methods of product application..

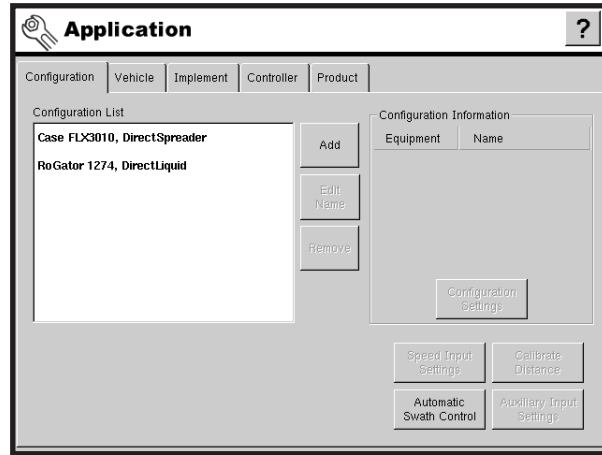

**Product Application Setup - Prior To Configuration**

Item	Description
<b>Configuration</b>	Add and edit operating configurations. Operating configurations are a combination of Vehicle, Implement, and Controller(s).  Configuration examples: <ul style="list-style-type: none"> <li>• Self propelled sprayer with PWM valve rate control</li> <li>• Pull-Type sprayer with servo valve rate control</li> <li>• Single product self-propelled fertilizer spreader with hydraulic servo valve control</li> </ul>
<b>Vehicle</b>	Add and edit vehicle configurations. Settings include GPS offsets of rear axle and implement mounts in relation to GPS antenna.
<b>Implement</b>	Add and edit implement configurations. Settings include product dispense and swath locations in relation to GPS antenna and vehicle hitch.
<b>Controller</b>	Add and edit product control channels. Settings include product control valve and response threshold values.
<b>Product</b>	Add and edit crop nutrient and protection products. Allows configuration of fertilizer blends and tank mixes.

## GRAIN HARVEST YIELD MONITORING SETUP

The Grain Harvest setup screens contain all the necessary settings for configuration of yield monitoring operations.

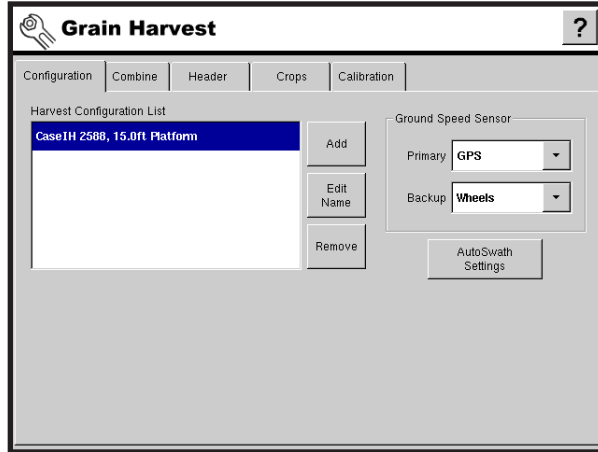

**Grain Harvest Yield Monitor Setup - Prior To Configuration**

Item	Description
<b>Configuration</b>	Add and edit operating configurations. Operating configurations are a combination of Combine and Header.
<b>Combine</b>	Add Combines from a list of all supported platforms.
<b>Header</b>	Add and edit row, pickup, and platform style headers. Settings include platform width and header lift switch configuration.
<b>Crops</b>	Add and edit crop type and varieties.
<b>Calibration</b>	Provides access to all calibration settings related to an operating configuration.

## COTTON HARVEST YIELD MONITORING SETUP

The Cotton Harvest setup screens contain all the necessary settings for configuration of yield monitoring operations. For more information, see the Cotton Harvest Insert.

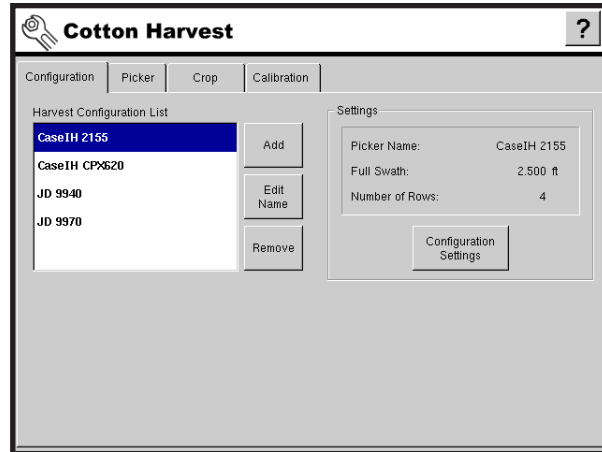

**Cotton Harvest Yield Monitor Setup - Prior To Configuration**

Item	Description
<b>Configuration</b>	Add and edit operating configurations. Operating configurations are a combination of picker and head type.
<b>Picker</b>	Add pickers from a list of all supported platforms.
<b>Crop</b>	Add and edit crop and varieties.
<b>Calibration</b>	Provides access to all calibration settings related to an operating configuration.

## GPS GENERAL TAB

There are three main tabs under the **DGPS** button that display detailed information about the GPS signal and receiver.

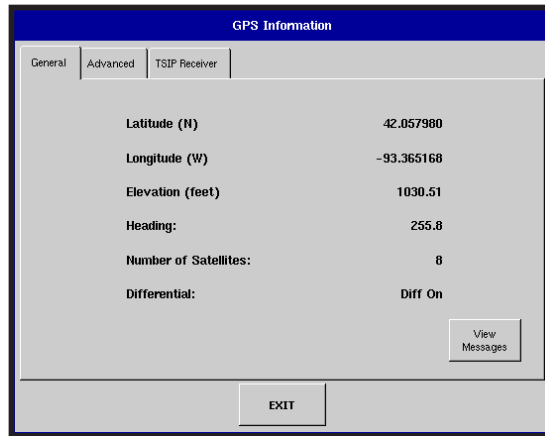

**DGPS General Tab**

Item	Description
<b>Latitude, Longitude, Elevation</b>	Displays current position (in longitude and latitude) and elevation.
<b>Heading</b>	Displays degree heading of travel
<b>Number of Satellites</b>	Displays the number of satellites currently being tracked by the receiver.
<b>Differential</b>	<p>If a TSIP receiver is being used, the differential status will display the differential source (i.e. WAAS, Beacon or OmniSTAR®). This message field will display either <b>Diff On</b> or <b>Diff Off</b>.</p> <ul style="list-style-type: none"> <li>• <b>Diff On</b> - indicates the receiver is receiving a differential GPS signal.</li> <li>• <b>Diff Off</b> - indicates the receiver is not receiving a differential GPS signal.</li> </ul>
	To view the NMEA messages coming from the receiver, press the <b>View Messages</b> button.

## GPS ADVANCED TAB

The advanced tab displays more diagnostic information about the GPS receiver. The Coordinated Universal Time, position errors (HDOP and/or PDOP), GPS speed, and update rate are displayed for receivers.

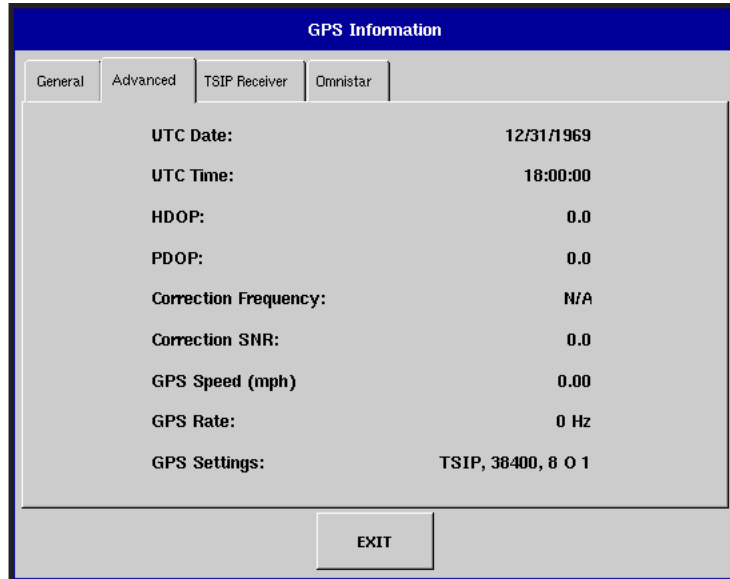

**Advanced Tab**

Item	Description
<b>UTC</b>	<p>UTC is an acronym for Coordinated Universal Time, a high-precision atomic time standard that defines local time throughout the world. Different versions of universal time use atomic clocks to correct for irregularities in the earth's rotation and orbit. UTC is used in navigation, astronomy, aviation, Internet broadcasts, and amateur radio.</p> <p>If you are receiving information from the satellite, then the UTC should automatically update.</p>
<b>HDOP</b>	<p>Horizontal Dilution of Precision (HDOP) indicates the quality of the horizontal GPS position. Lower HDOP numbers are optimal, higher numbers are undesirable.</p>
<b>PDOP</b>	<p>Position Dilution of Precision (PDOP) is a unitless measure indicating when the satellite geometry can provide the most accurate results. When satellites are spread around the sky, the PDOP value is low and the computed position is more accurate. When satellites are grouped close together, the PDOP is high and the positions are less accurate. Lower PDOP numbers are optimal, higher numbers are undesirable.</p>
<b>Correction Frequency</b>	<p>The Correction Frequency indicates the GPS satellite frequency used by the receiver.</p> <p><b>NOTE: The Correction Frequency diagnostic does not show for WAAS connections.</b></p>

## GPS ADVANCED TAB (Continued)

Item	Description
<b>Correction SNR</b>	<p>If your receiver is using Beacon differential corrections, the frequency and Signal-To-Noise Ratio (SNR) will be displayed.</p> <p>Signal-to-Noise Ratio (SNR) indicates the strength of the differential correction signal in relation to the amount of background noise that can interfere with signal reception. A good SNR is 10 to 18.</p>
<b>GPS Speed (MPH)</b>	The speed of the vehicle.
<b>GPS Rate</b>	The update rate from the GPS receiver, shown in Hz.
<b>GPS Settings</b>	<p>These settings include the following, which are displayed from left to right in the Advanced Tab illustration on the previous page:</p> <ul style="list-style-type: none"> <li>• (Left) The protocol being used by the receiver. In the example, the receiver is using the TSIP protocol.</li> <li>• (Middle) The Baud Rate of the data received. In the example, the Baud Rate is 38,400.</li> <li>• (Right) The data bits, parity, and stop bits of the GPS signal. In the example, the data bits are 8, the parity is 0, and the stop bits are 1. This number is used in error detection, as it determines the integrity of data received after transmission.</li> </ul>

## TSIP RECEIVER TAB

If a TSIP receiver is being used, the TSIP Receiver tab will display appropriate diagnostics information. The receiver Product ID, Firmware Version, and Voltage are displayed in the top frame. The options frame tells you if the Fast Update Rate or Everest Multipath features are enabled.

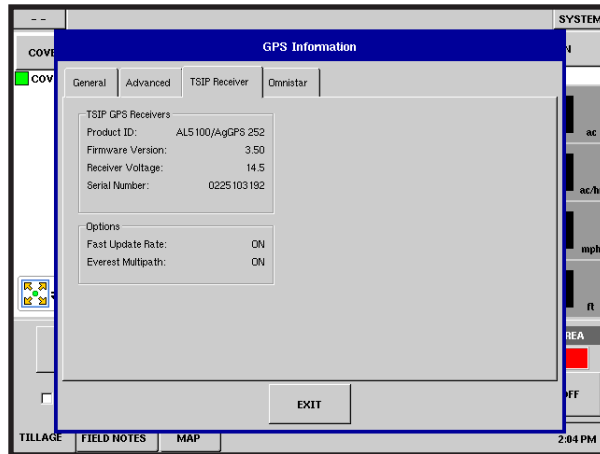

**TSIP Receiver Tab**

Item	Description
<b>TSIP GPS Receiver Information</b>	Displays Product ID, Firmware Version, and Voltage.
<b>Fast Update Rate</b>	<p>The Fast Update Rate indicates whether your receiver is capable of outputting an update rate faster than 1 Hz per second.</p> <ul style="list-style-type: none"> <li>• If the Fast Update Rate is ON, then your receiver is capable of outputting an update rate faster than 1 Hz per second.</li> <li>• If the Fast Update Rate is OFF, then currently your receiver is only capable of an update rate of 1 Hz per second. Contact KINZE Service Department, through you local KINZE Dealer, to see if your receiver can be upgraded to a faster update rate. This may require an unlock code from KINZE.</li> </ul>
<b>Everest Multipath</b>	<p>The Everest Multipath feature helps eliminate errors caused by signal deflection off of buildings or other structures. If this is ON, then your receiver has this feature; if it is OFF then your receiver does not.</p> <p><b>NOTE: Some older receivers may not be capable of the Everest Multipath feature.</b></p>

## OMNISTAR® TAB

The OmniSTAR diagnostic tab will appear if you have purchased this wide-area differential GPS correction service.

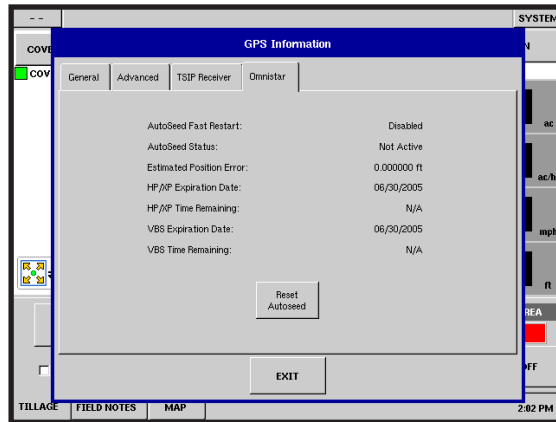

OmniSTAR® Tab

Item	Description
<b>AutoSeed Fast Restart</b>	<p>The AutoSeed™ Fast Restart feature reduces the time needed for your receiver to reconverge (re-average) your GPS position, thus ensuring a quick and efficient startup. The Fast Restart field indicates one of three types of status: Disabled, Reading or User Rejected.</p> <p><b>Disabled</b> - The AutoSeed feature is off.</p> <p><b>Reading</b> - The AutoSeed feature is currently being used.</p> <p><b>User Rejected</b> - The AutoSeed feature has been disabled by the user.</p>
<b>AutoSeed Status</b>	<p>The AutoSeed status indicates ACTIVE or NOT ACTIVE, depending upon whether this feature is on or off.</p>
<b>Estimated Position Error</b>	<p>The estimated position error relative to your actual position, shown in feet. This may be a greater number when you first start up your GPS system, but it should diminish with time.</p>
<b>HP/XP Expiration Date</b>	<p>The HP/XP Expiration Date is the date on which your HP/XP subscription ends. For more information, contact OmniSTAR®.</p>
<b>HP/XP Time Remaining</b>	<p>The HP/XP Time Remaining is the amount of time left on your HP/XP subscription. For more information, contact OmniSTAR®.</p>
<b>VBS Expiration Date</b>	<p>The VBS Expiration Date is the date on which your VBS subscription ends. For more information, contact OmniSTAR®.</p>
<b>VBS Time Remaining</b>	<p>The VBS Time Remaining is the amount of time left on your VBS subscription. For more information, contact OmniSTAR®.</p>
	<p>The <b>Reset Autoseed</b> button allows you to reconverge your GPS position. This reset feature should be used if the vehicle has moved after the GPS receiver was turned off.</p> <p><b>NOTE: After you press this button, the receiver will take a certain amount of time as the reconvergence takes place. Therefore, your GPS position will be less accurate for a time until the reconvergence is completed.</b></p>

## SYSTEM DIAGNOSTIC BUTTON

By pressing the **System** button, you can view the System Information window, which includes the General, Display, and CAN tabs. This window shows generalized Diagnostic information, such as memory, display, CAN device and firmware version information. Technical support may request that you look at this window to help in diagnosing a problem. Additional tabs, appropriate to the connected modules, are present as needed. For information on these additional tabs, see the Planting section under “*System Diagnostic Button*” on page 6-21. Information on LED diagnostic states can be found at “*Module LED Diagnostic States*” on page 7-6.

### General Tab

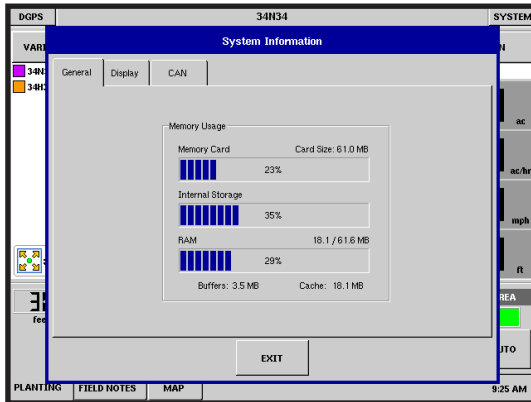

The General Tab contains information about the external storage card and display memory usage.

### Display Tab

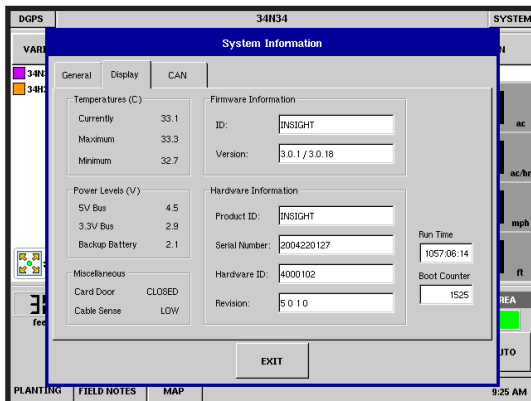

The Display tab shows general and diagnostic information about the KINZE Vision display. Information includes:

- Display Temperature
- Display And CAN Bus Voltage
- Firmware Information
- Hardware Information
- Display Run Time Hours:Minutes:Seconds
- Display Boot Counter

### CAN Tab

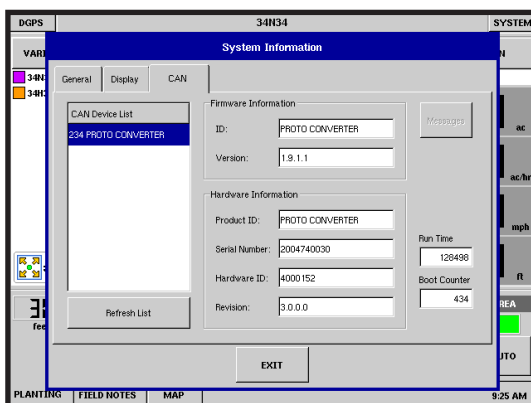

The CAN Device List displays the modules that are connected to the CAN Bus. Press the **Refresh List** button to have the KINZE Vision display search for any new modules that are connected to the CAN Bus. Select a device to display specific details in the Firmware and Hardware Information frames of the CAN tab.





**NOTE:** Check the CAN device list to ensure that all modules appear there.

## FIELD NOTES TAB

When an active configuration is selected at the Run screen, the Field Notes and related functionality will be present.



Field Notes Tab - Bottom Of Run Screen

Item	Description
 <b>MARKERS</b>	<p>Press the <b>Note</b> button to launch an on-screen dialog that allows attaching a text memo to the current field location.</p> <p>Multiple text memo items can be created in each field.</p>
 <b>USER DEFINED MARKERS</b>	<p>Press to add a point in the field with the desired attribute. These markers are defined in the Field Notes section of General setup.</p>
	<p>Press the <b>Fill Empty</b> button to access the container fill events dialog. This functionality is only used during liquid product application.</p>
	<p>Press the <b>Report Details</b> button to add specific, detailed content to KINZE Vision product application reports. A complete description of this functionality is contained in the application control content of the user guide.</p>

## USING FIELD NOTES

The Field Notes tab contains functionality to mark points and attach text memos to points in a field at the Run screen. The Field Notes information is stored in the KINZE Vision data log file for use with desktop GIS software.

### Markers Created At Run Screen

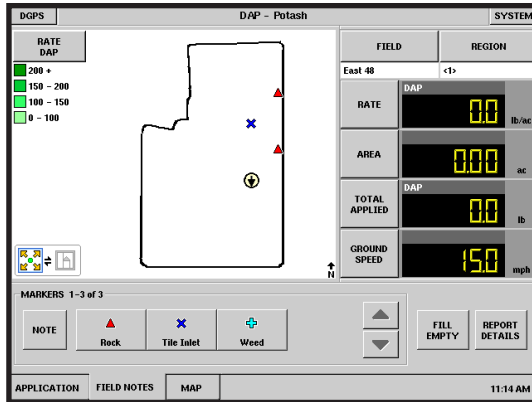

Press a markers button to map points with attached data in the field. The example at the left shows a field that two rocks and one tile inlet have been mapped in. Markers are defined in Field Notes. For more information on Field Notes, see *“General Setup Overview”* on page 4-12.

### Field Notes Text Memo

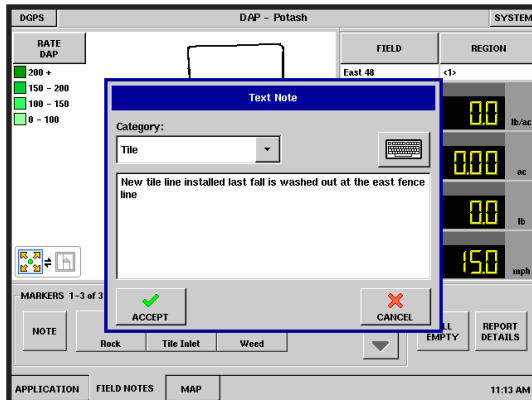

Press the NOTE button to launch an on-screen dialog that allows attaching a text memo to the current field location.

Multiple text memo items can be created in each field.

Select the type of Text Note from the items in the Category list box. The pre-defined types available are: General, Pest, Weed, Field, and Tile.





Use the on-screen keyboard to enter the text note and press ACCEPT to finish.

## MAP TAB BASICS



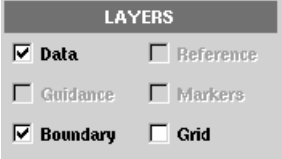

When an active configuration is selected at the Run Screen, the Map tab and related functionality will be present.



**Map Tab Functionality**

Button	Description
	<p>Press the <b>LOAD Rx</b> button to load a GPS-referenced product application rate map.</p>
	<p>Press the <b>LOAD REFERENCE</b> button to load and display a background map from another operation. An example of this is loading a reference map of a planted seed variety while harvesting a crop. From the on-screen dialog box, select the desired operation and attribute to display. Press <b>ACCEPT</b> to continue.</p>
	<p>The <b>CLEAR REFERENCE</b> button is not active until there is a reference map loaded. Press this button to clear the current reference map from the Run screen.</p>
	<p>The Layers part of the Map Tab includes the following check box options:</p> <ul style="list-style-type: none"> <li>• <b>Data</b> - Shows data displayed on current map.</li> <li>• <b>Guidance</b> - Shows A line and B line for lightbar users.</li> <li>• <b>Boundary</b> - Displays boundaries loaded into the KINZE Vision display.</li> <li>• <b>Reference</b> - Shows reference map.</li> <li>• <b>Markers</b> - Displays markers specified in Field Notes.</li> <li>• <b>Grid</b> - Overlays a grid on the map.</li> </ul>
	<p>Press the <b>MAP OPTIONS</b> button to display an on-screen dialog box that presents options for removing mapped data from the screen. These map options are:</p> <ul style="list-style-type: none"> <li>• <b>CLEAR MAP</b> = Permanently removes all logged data from the active field operation.</li> <li>• <b>CLEAR MARKS</b> = Permanently removes all mapped marks from the active field.</li> </ul>
	<p>Check the <b>Zoom Detail Map Rotation</b> check box to enable zoom detail, which displays a rotating map with the vehicle at the center of the display. For more detail, see <i>"Map Zoom Detail"</i> on page 4-66.</p>

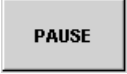
## MAP TAB BASICS (Continued)

Button	Description
	<p>Press the <b>START</b> button to display a dialog box that starts the process of creating a field boundary. For more details see <i>"Field Boundary Creation"</i> on page 4-67.</p>
	<p>The <b>STOP</b> button is only active after a boundary has been started. Press to finish collecting the active boundary object.</p>
	<p>Press the <b>VIEW</b> button to view all mapped boundaries and associated area for the active field. Boundary objects can be selected and deleted from the View Boundary dialog box.</p>
 	<p>The <b>PAUSE</b> and <b>RESUME</b> buttons are only displayed at the appropriate times during the process of mapping a field boundary. A common use of these buttons would be pausing boundary collection while driving around an obstruction in a fence line and resuming boundary collection after clearing the obstruction. The KINZE Vision system will automatically connect the points where boundary collection was paused and resumed and show the actual field boundary without the obstruction.</p>

## MAP ZOOM DETAIL

The Zoom Detail changes the Run screen's appearance so that the vehicle icon is always shown pointed to the top.

### Check Zoom Detail Map Rotation Box



To enable the Zoom Detail feature, check the **Zoom Detail Map Rotation** check box on the Map Tab.

### Zoom To Extent

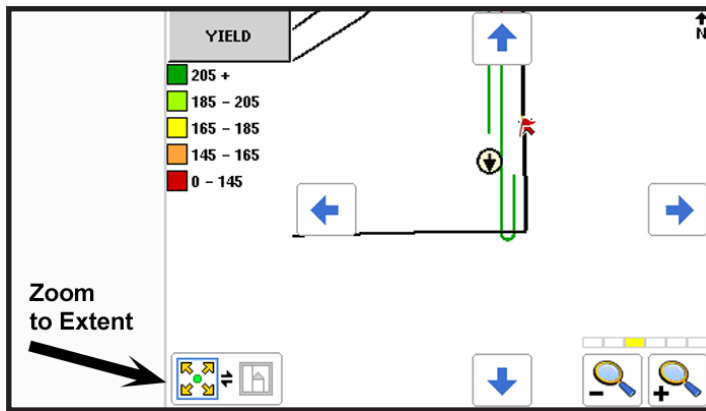

On the Run screen, an icon at bottom left gives you the option of either Zoom to Extent (normal view) or Zoom Detail.

At left is the Zoom to Extent view. The vehicle is traveling southbound, and as such, is shown pointing toward the bottom of the Run screen. As it approaches the upcoming turn, the vehicle icon will change direction.

### Zoom Detail

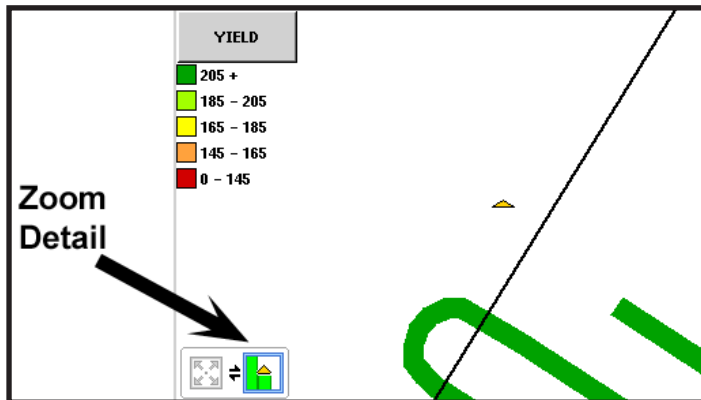

Change to Zoom Detail by pressing the Zoom Detail icon at bottom left. The view changes so that the vehicle icon is shown pointed toward the top, even as it turns corners.

In other words, in Zoom Detail, the rest of the field is shown with its spatial relationship changed in accordance with the vehicle, not the other way around.

## FIELD BOUNDARY CREATION

The following image shows the dialog box that is displayed after pressing the **START** field boundary button.

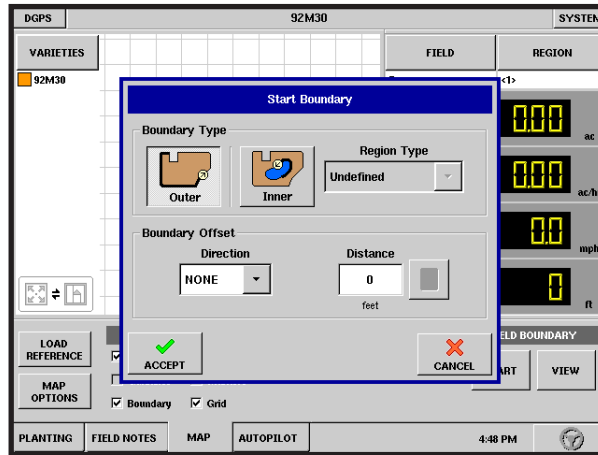

### Boundary Type

The boundary type can either be an Outer or an Inner boundary. If inner boundary is chosen, select the type of boundary from the Region Type list box. Region types are:

- Roadway
- Body Of Water
- Waterway
- Buildings
- Undefined

### Boundary Offset

The boundary offset feature enables mapping a boundary at a user-defined distance to the left or right of the GPS antenna centerline.

# SYSTEM OVERVIEW

---

**This page intentionally left blank.**

## CONFIGURATION

The Planting setup pages contain all the necessary settings to configure the system for logging, mapping, and rate control for planting operations. The combination of Vehicle, Implement, Controller and Product are referred to as a **Configuration** within the KINZE Vision system.

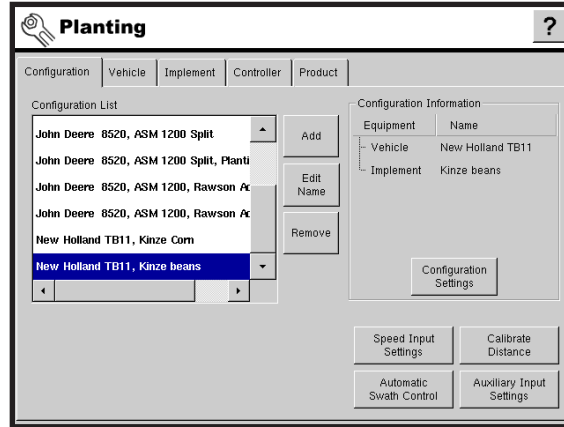

**Planting Tabs**





Planting Setup Tab	Description
<b>Configuration</b>	The <b>Configuration</b> Tab is where you can add and edit operating configurations. For more information, see <i>“Configuration Tab Buttons” on page 5-2.</i>
<b>Vehicle</b>	The <b>Vehicle</b> Tab is where you can add and edit vehicle configurations. For more information, see <i>“Vehicle Tab” on page 5-27.</i>
<b>Implement</b>	The <b>Implement</b> Tab is where you can add and edit implement configurations. For more information, see <i>“Implement Tab” on page 5-30.</i>
<b>Controller</b>	The <b>Controller</b> Tab is where you can add and edit controllers for use during planting. For more information, see <i>“Controller Tab” on page 5-51.</i>
<b>Product</b>	The <b>Product</b> Tab is where you can add and edit new products or edit existing products for planting and seeding. For more information, see <i>“Product Tab” on page 5-55.</i>

## CONFIGURATION TAB BUTTONS

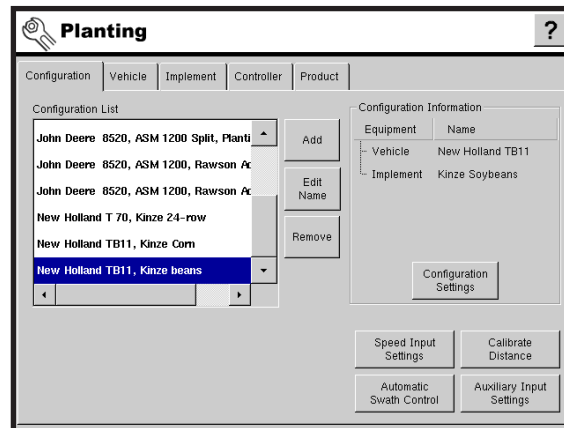

The Configuration Tab is where planting and seeding configurations are made and displayed. The configuration settings are also edited on this tab. To go to this window, press the **Setup** button and then the **Planting/Seeding** button.

- To see a Planting Configuration Menu, see “SeedCommand™ Menu Tree” on page 7-3.
- For required setup before this configuration can be used, see “Setup Tips” on page 4-11.

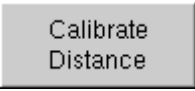

Button	Description
	Press to add a new planting or seeding configuration. An on-screen wizard will walk you through the setup process in a step-by-step manner. New Vehicles, Implements, and controllers can be created during the setup process. For site verification wizard guidance see “ <i>ADDING A NEW SITE VERIFICATION CONFIGURATION (Continued)</i> ” on page 5-6. For rate control/ logging wizard guidance, see “ <i>Adding A New Rate Control/Logging Configuration</i> ” on page 5-8.
	Press to edit the name of a selected configuration. The on-screen keyboard will be displayed to complete the desired text edits.
	Press to remove a configuration. The vehicle and implement associated with the configuration will not be deleted.  <b>IMPORTANT: When deleting a configuration, all regions and data logged with that configuration will be deleted.</b>
	Press to display and edit planting/seeding settings specific to a vehicle, implement, controller combination. For more information see “ <i>Configuration Settings</i> ” on page 5-19.

## CONFIGURATION TAB BUTTONS (Continued)

Button	Description
	Press to select speed input device.
	Press to launch speed sensor calibration wizard. For detailed information see <i>“Calibrate Distance” on page 5-23.</i>
	Press to display and edit automatic swath control settings. For more information, see <i>“Automatic Swath Control Settings” on page 5-20.</i>
	Press to display master switch input setting. For more information, see <i>“Auxiliary Input Settings (Switch Mapping)” on page 5-25.</i>

## CONFIGURATION BASICS

The process of creating a new **Configuration** is done in a step-by-step manner. An on-screen wizard guides you through the process of creating **Vehicle**, **Implement**, and **Controller** combinations.

In most cases, **Configurations** will be created by pressing the **Add** button on the Configuration tab. Step-by-step examples of creating configurations include the following:

- “Adding A New Area Logging (Site Verification) Configuration” on page 5-5
- “Adding A New Rate Control/Logging Configuration” on page 5-8
- “Adding An Additional Equipment Configuration” on page 5-17
- “SeedCommand™ KINZE® Planter Monitor Configuration” on page 5-60
- “SeedCommand™ Clutch Control Configuration” on page 5-66

It is recommended that all new equipment configurations be set up from the Configuration tab. If the need arises, new **Vehicles**, **Implements** or **Controllers** can be created individually from each tab.

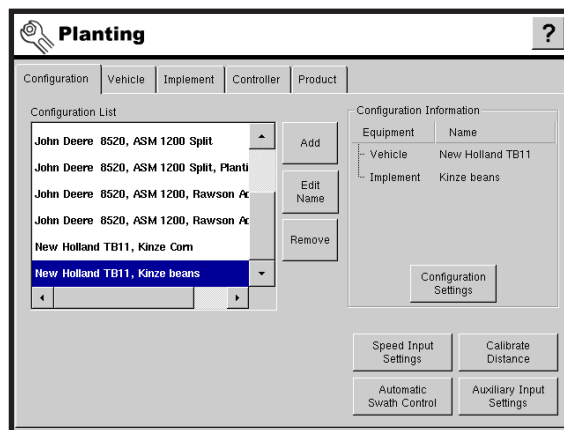

Planting Configurations

## ADDING A NEW AREA LOGGING (SITE VERIFICATION) CONFIGURATION

To add a new site verification planting or seeding configuration, press the **Add** button. The Operating Configuration Wizard appears, as shown below.

### STEP 1 Select a Vehicle

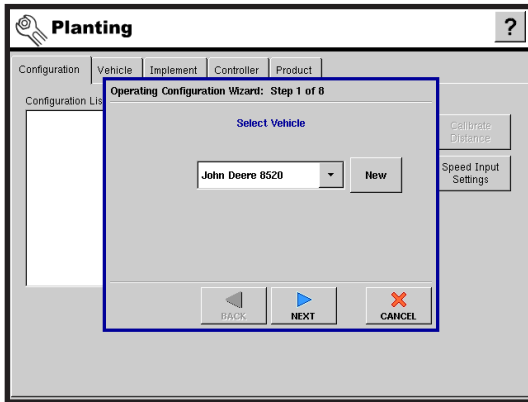

Using the drop down box, select the vehicle you would like to use in this configuration. If there are no vehicles in the list press the **New** button.

**NOTE:** For help with the Adding a New Vehicle Wizard, see *“Adding A New Vehicle”* on page 5-28.

Press **Next** to continue.

### STEP 2 Select Implement

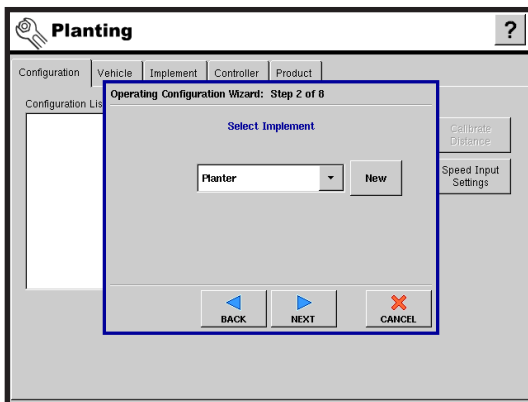

Using the drop down box, select the implement you would like to use in this configuration. If there are no implements in the list, press the **New** button.

**NOTE:** For help with the Adding a New Implement Wizard, see *“Adding A New Implement”* on page 5-32.

Press **Next** to continue.

### STEP 3 Select Operation Type

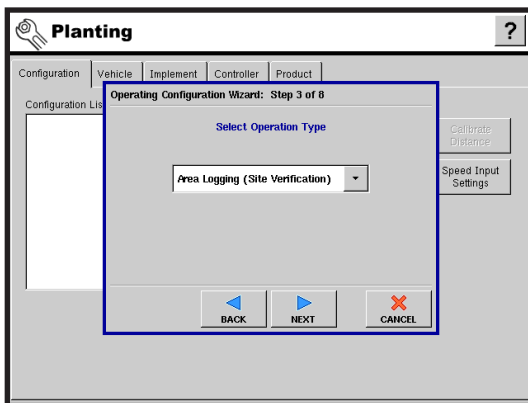

Select the operation type. You can either choose **Area Logging (Site Verification)** or **Rate Logging/Control**. In this case choose **Area Logging (Site Verification)**.

**NOTE:** If the multiple product unlock has not been purchased skip to *“STEP 6”* on page 5-6.

Press **Next** to continue.

## ADDING A NEW SITE VERIFICATION CONFIGURATION (Continued)

### STEP 4 Select Planting Method

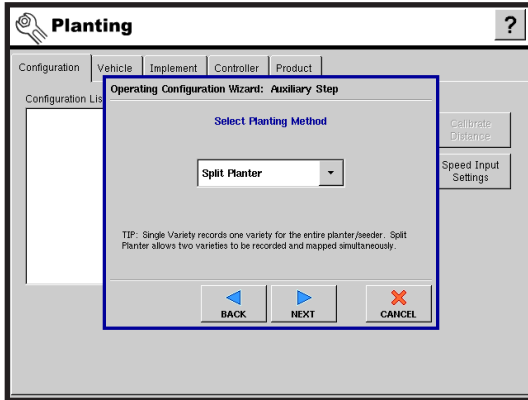

Use the drop down box to select the planting method. You can either choose **Single Variety** or **Split Planter**.

**NOTE:** The Split Planter Configuration cannot be used for Single Variety planting. If you are planting a single variety, you must create a Single Variety configuration.

Press **Next** to continue.

### STEP 5 Add Additional Equipment

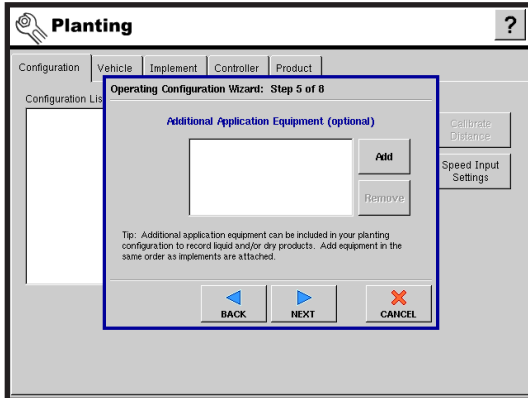

This is an optional step. If you would like to apply another product with your selected implement, or add an additional implement to apply another product press **Add**.

**NOTE:** For help with adding or creating an additional equipment configuration see *“Adding An Additional Equipment Configuration”* on page 5-17.

Press **Next** to continue.

### STEP 6 Select Implement Switch

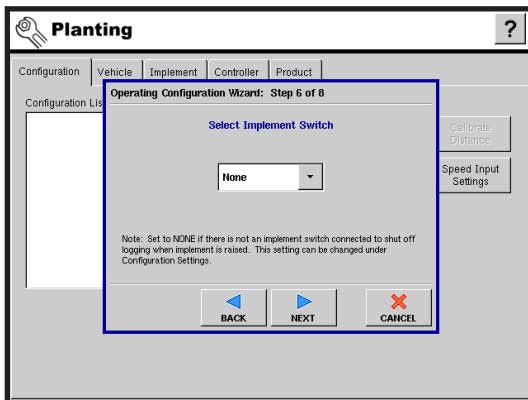

If you are using an implement switch, choose whether it is set up as **Standard** (normally **ON**) or **Reversed** (normally **OFF**). Otherwise choose **None**.

Press **Next** to continue.

## ADDING A NEW SITE VERIFICATION CONFIGURATION (CONTINUED)

### STEP 7 Choose Ground Speed Source

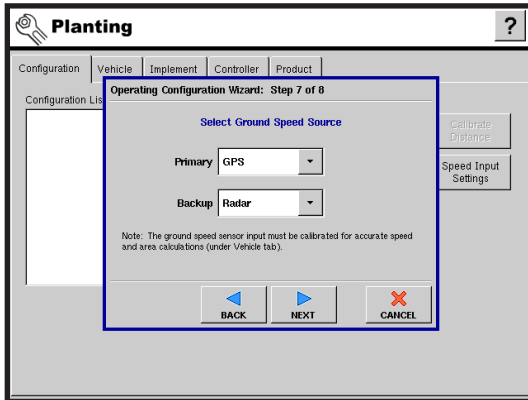

Select your ground speed source. If you will be using GPS as the primary you will need to select a secondary source.

Press **Next** to continue.

### STEP 8 Edit Configuration Name

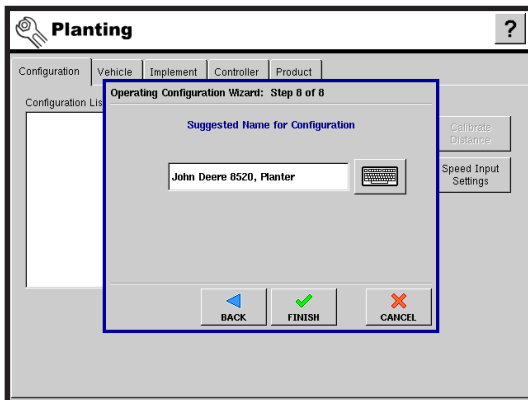

Use the keyboard button to edit the name of the configuration.

Press **Finish** to complete the setup process.

## ADDING A NEW RATE CONTROL/LOGGING CONFIGURATION

To add a new serial controlled planting or seeding configuration press the **Add** button.

### STEP 1 Select a Vehicle

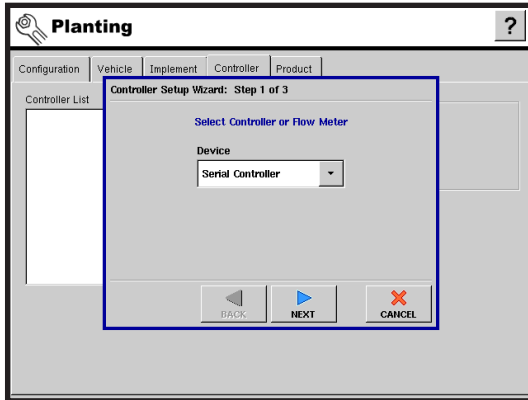

Using the drop down box select the vehicle you would like to use in this configuration. If there are no vehicles in the list press the **New** button.

**NOTE:** For help with the adding a new vehicle wizard see *“Adding A New Vehicle”* on page 5-28.

Press **Next** to continue.

### STEP 2 Select Implement

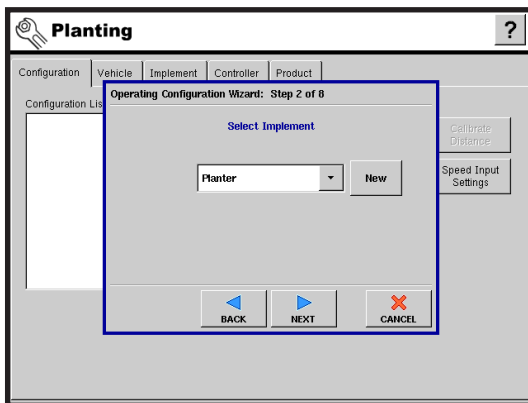

Using the drop down box select the implement you would like to use in this configuration. If there are no implements in the list press the **New** button.

**NOTE:** For help with the adding a new implement wizard see *“Adding A New Implement”* on page 5-32.

Press **Next** to continue.

### STEP 3 Select Operation Type

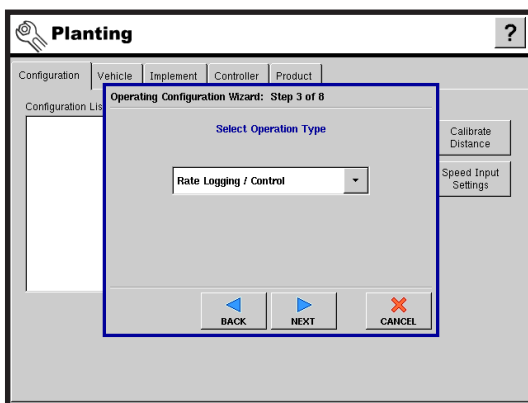

Select the operation type. You can either choose **Area Logging (Site Verification)** or **Rate Logging/Control**. In this case, choose **Rate Logging/Control**.

Press **Next** to continue.

## ADDING A NEW RATE CONTROL/LOGGING CONFIGURATION (Continued)

### STEP 4 Select Controller

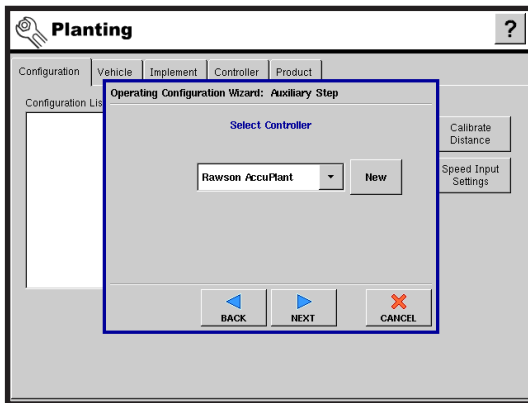

Select the controller you will be using from the drop down list. If a new controller must be created press the new button.

**NOTE:** See “Adding A New Controller” on page 5-53 for help with the wizard.

Press **Next** to continue.

### STEP 5 Controller Information

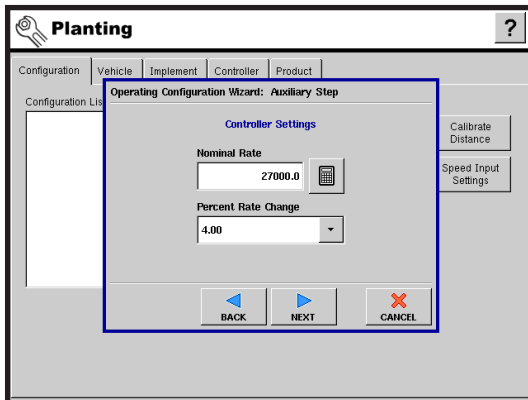

After selecting the controller, controller settings will need to be entered. In this case a Rawson AccuPlant or AccuRate was selected and has one page of setup.

**NOTE:** If the multiple product unlock has not been purchased skip to “STEP 7” on page 5-10.

Press **Next** to continue.

### STEP 6 Add Additional Equipment

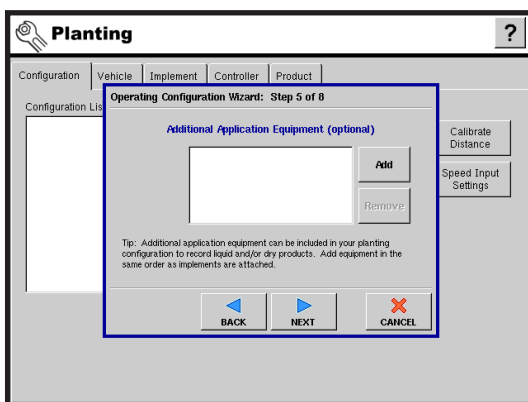

This is an optional step. If you would like to apply another product with your selected implement or add an additional implement to apply another product, press **Add**.

**NOTE:** For help with adding or creating an additional equipment configuration see “Adding An Additional Equipment Configuration” on page 5-17.

Press **Next** to continue.

# CONFIGURATION      CREATING A NEW CONFIGURATION

## ADDING A NEW RATE CONTROL/LOGGING CONFIGURATION (Continued)

### STEP 7 Choose Ground Speed Source

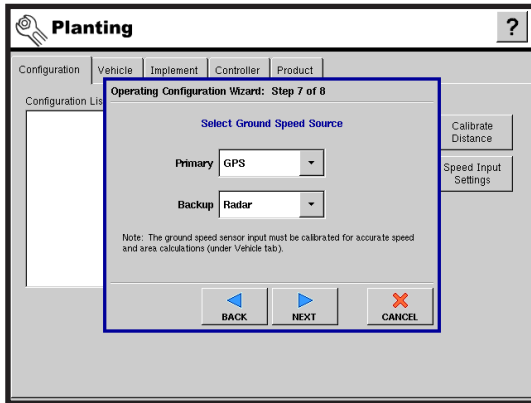

Select your ground speed source. If you will be using GPS as the primary you will need to select a secondary source.

Press **Next** to continue.

### STEP 8 Edit Configuration Name

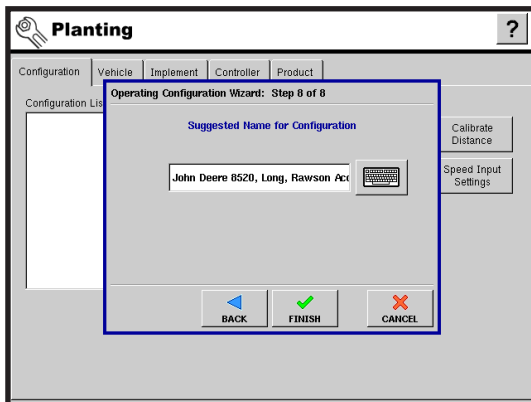

Use the keyboard button to edit the name of the configuration.

Press **Finish** to complete the setup process.

## ADDING A MULTI-VARIETY PLANTING CONFIGURATION

**Note:** The following procedure describes how to configure a multi-variety planting configuration. This is an optional feature of the KINZE Vision system. An unlock code must be purchased and installed to enable this feature. Call your local KINZE Dealer for details and pricing.

To add a new multi-variety planting configuration, press the **Add** button. The Operating Configuration Wizard appears, as shown below.

### STEP 1 Select Vehicle

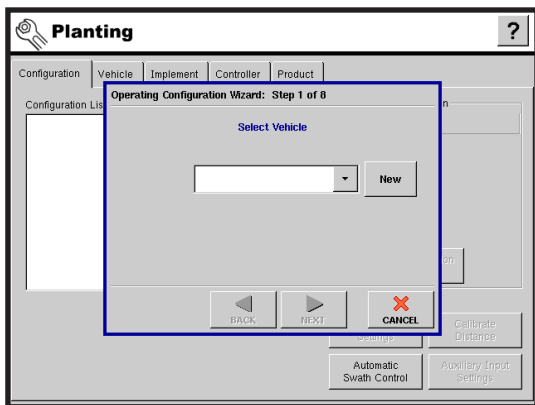

Using the drop down box select the vehicle you would like to use in this configuration.

If there are no vehicles in the list, press the **New** button, and the Vehicle Setup Wizard appears, as shown in the following window.

**NOTE:** For help with the adding a new vehicle, see *“Adding A New Vehicle”* on page 5-28.

Press **Next** to continue.

### STEP 2 Enter Tractor Make and Model

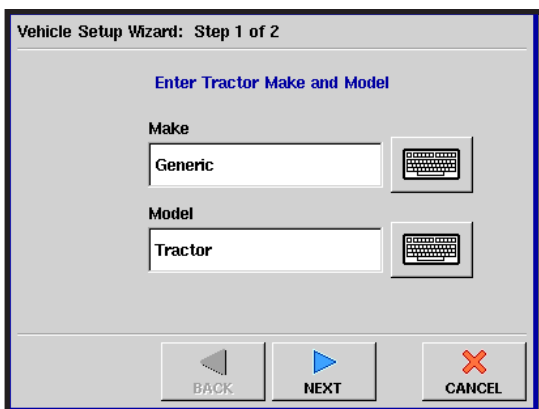

Use the on-screen keyboard to enter in the make and model of the tractor.

Press **Next** to continue.

### STEP 3 Enter Suggested Tractor Name

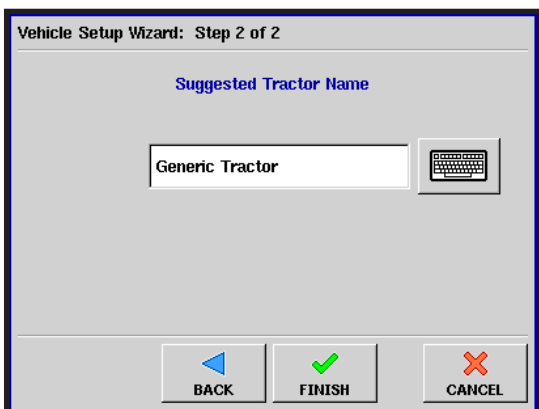

A suggested tractor name appears. If necessary, use the on-screen keyboard to edit the name of the tractor.

Press **Finish**, and the Operating Configuration Wizard reappears, as shown on the following page.

## ADDING A MULTI-VARIETY PLANTING CONFIGURATION (Continued)

### STEP 4 Select Implement



Using the drop down box select the implement you would like to use in this configuration. If there are no implements in the list, press the **New** button.

**NOTE:** For help with the adding a new implement wizard, see *“Adding A New Implement”* on page 5-32.

Press **Next** to continue.

### STEP 5 Select Planter/Seeder Type

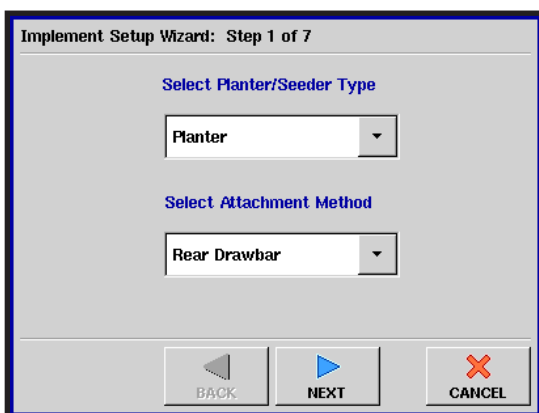

The Implement Setup Wizard appears, as shown at left. From the top drop down menu, select either Planter or Seeder/Drill. Then use the bottom drop-down menu to select either Rear Drawbar or Rear 3-Point Hitch.

Press **Next** to continue.

### STEP 6 Implement Options

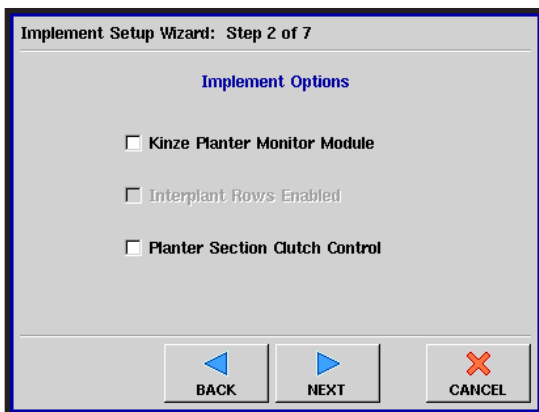

Select the following Implement Options, depending upon your desired configuration:

- **KINZE Planter Monitor Module** - Check this box to enable the KINZE Vision planter monitor functions.
- **Interplant® Rows Enabled** – Check this box to enable to log data from a KINZE planter’s Interplant® push row units.
- **Planter Section Clutch Control** – Check this box to enable the SeedCommand planter clutches.

This procedure assumes that none of these options are selected. Press **Next** to continue.

## ADDING A MULTI-VARIETY PLANTING CONFIGURATION (Continued)

### STEP 7 Enter Number of Rows and Spacing

Use the up and down arrow keys to enter the number of rows and their spacing.

Press **Next** to continue.

### STEP 8 Enter Number of Implement Sections

Use the up and down arrow keys to enter the number of sections that you want to appear on the Planting Tab on the Run screen. You may enter up to three implement sections (assuming that you did not check any Implement Options on "STEP 6" on page 5-12).

- If using a one- or two-section split planter, enter two implement sections.
- If using three varieties, choose one or three sections.

**NOTE: Do not enter the number of individual rows. Enter the number of swath sections that can be independently turned on and off.**

Press **Next** to continue.

### STEP 9 Enter Section Widths from Left to Right

Section	Number of Rows
1	4
2	4
3	4
4	4

For implements with more than one swath section, the system will default to the appropriate number of equal width swath sections. In this instance, two equal sections of eight rows are shown in this window.

To edit any of the swath values, select the desired section from the list and press the numeric keypad to enter in a new width.

Press **Next** to continue.

## ADDING A MULTI-VARIETY PLANTING CONFIGURATION (Continued)

### STEP 10 Enter Distance From Hitch To Application Point

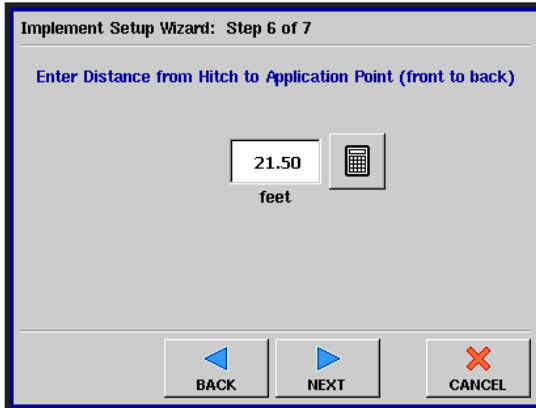

Enter the distance from the hitch to the application point using the numeric keypad button.

Press **Next** to continue.

### STEP 11 Enter Implement Name

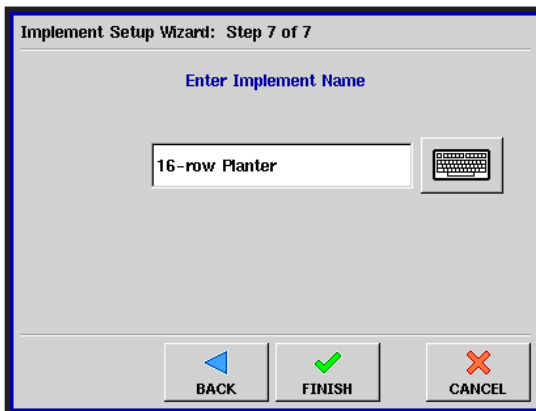

Use the keyboard button to enter a name for the implement.

Press the **Finish** button to complete the implement setup process and continue with the Operating Configuration Wizard.

### STEP 12 Select Operation Type

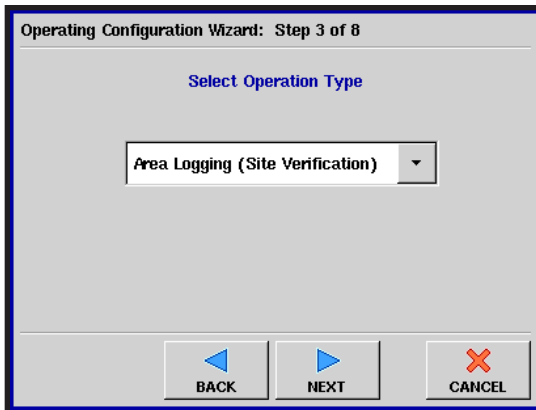

Select the operation type. Since we are creating a split planter configuration, you must choose **Area Logging (Site Verification)**.

**NOTE: A split planter configuration cannot be used with a serial controller.**

Press **Next** to continue.

## ADDING A MULTI-VARIETY PLANTING CONFIGURATION (Continued)

### STEP 13 Select Planting Method

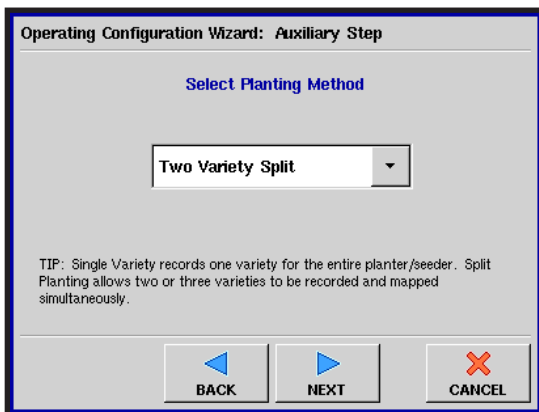

Use the drop down box to select the planting method. You may choose either Single Variety or Split Planter. In this case, select a Split Planter option.

**NOTE:** Your choices that appear in the drop down box have been predetermined based upon the sections that you specified in **“STEP 8” on page 5-13**. If you choose split planter, the number of varieties must equal the number of sections that you previously specified.

Press **Next** to continue.

### STEP 14 Add Additional Application Equipment

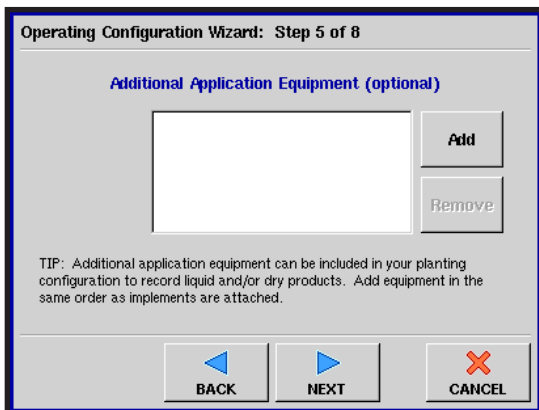

This is an optional step. If you would like to apply another product with your selected implement, or add an additional implement for the application of another product, press the **Add** button.

**NOTE:** For help with adding or creating an additional equipment configuration see **“Adding An Additional Equipment Configuration” on page 5-17**.

Press **Next** to continue.

### STEP 15 Select Implement Switch

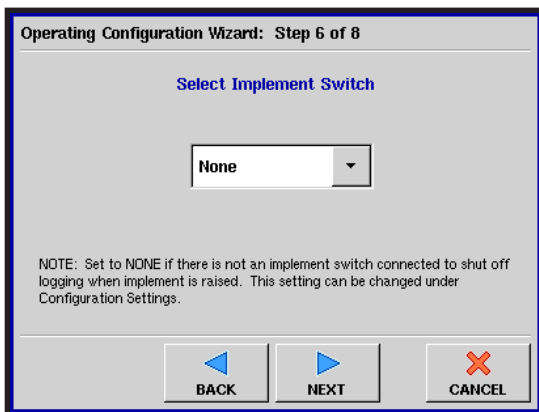

If you are using an implement switch, choose whether it is set up as **Standard** (normally **ON**) or **Reversed** (normally **OFF**). Otherwise choose **None**.

Press **Next** to continue.

## ADDING A MULTI-VARIETY PLANTING CONFIGURATION (Continued)

### STEP 16 Select Ground Speed Source

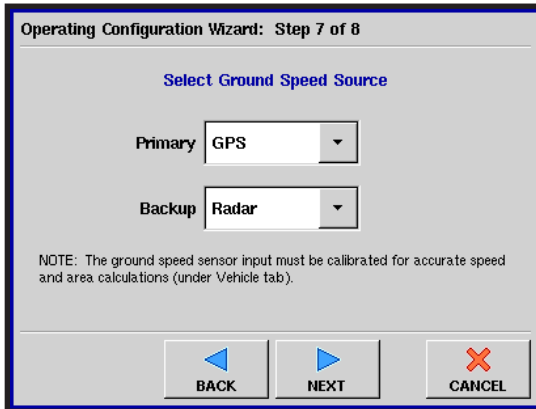

Operating Configuration Wizard: Step 7 of 8

Select Ground Speed Source

Primary

Backup

NOTE: The ground speed sensor input must be calibrated for accurate speed and area calculations (under Vehicle tab).

BACK NEXT CANCEL

Select your ground speed source. If you will be using GPS as the primary, you will need to select a secondary source.

Press **Next** to continue.

### STEP 17 Enter Suggested Name for Configuration

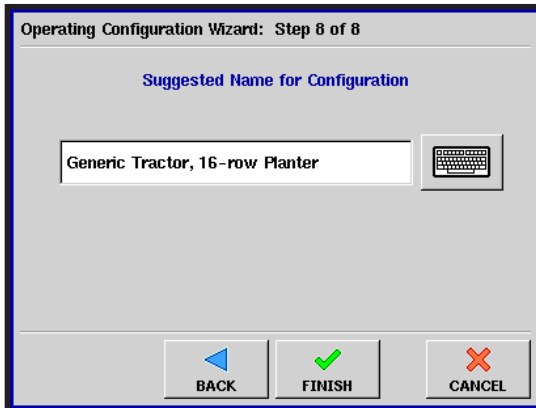

Operating Configuration Wizard: Step 8 of 8

Suggested Name for Configuration

Generic Tractor, 16-row Planter

BACK FINISH CANCEL

Use the keyboard button to edit the name of the configuration.

Press **Finish** to complete the setup process.

## ADDING AN ADDITIONAL EQUIPMENT CONFIGURATION

Adding an additional equipment configuration allows you to record and or control up to five products. This wizard will allow you to add an application implement that is already made or create a new one. This wizard is accessed from the **Add** button and the Multi-product unlock must be enabled.

- The equipment added can either be a site verification, serial controlled, or SeedCommand implement.
- Add the implements in the same order they are attached.

### STEP 1 Add Equipment

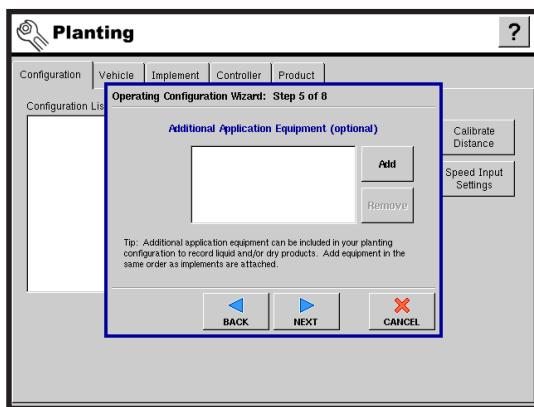

Press **Add** to add an additional application implement.

### STEP 2 Select Implement

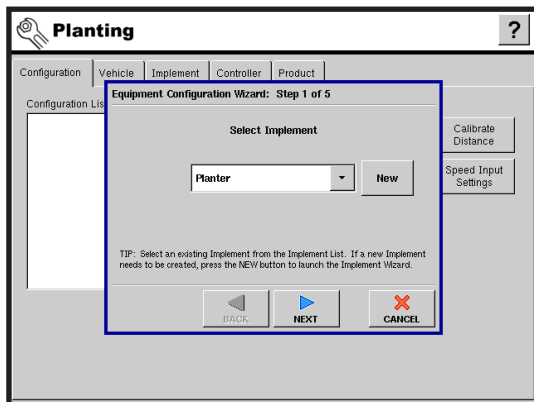

Using the drop down box select the implement you would like to use in this configuration. If there are no implements in the list press the **New** button.

**NOTE:** For help with adding a new implement wizard, see *“Adding A New Implement”* on page 5-32.

Press **Next** to continue.

### STEP 3 Select Operating Mode

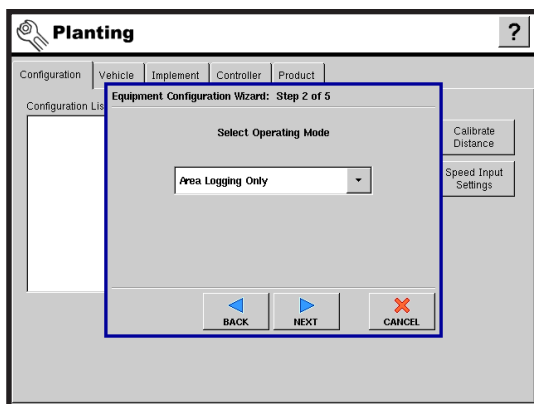

The implement can either record a product or control and record one.

- To only record the product, choose **Area Logging Only**.
- To control the product, choose **Rate Logging/Control**. If Rate Logging is chosen, see *“Serial Controlled Planting”* on page 6-4.

Press **Next** to Continue.

# CONFIGURATION      CREATING A NEW CONFIGURATION

## ADDING AN ADDITIONAL EQUIPMENT CONFIGURATION (Continued)

### STEP 4 Select Implement Switch

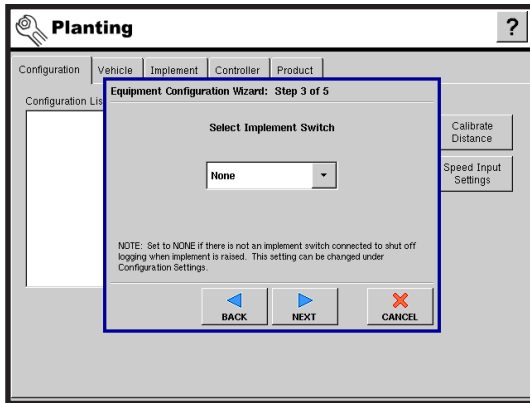

If you are using an implement switch, choose whether it is set up as **Standard** (normally **ON**) or **Reversed** (normally **OFF**). Otherwise choose **None**.

Press **Next**.

### STEP 5 Select Container

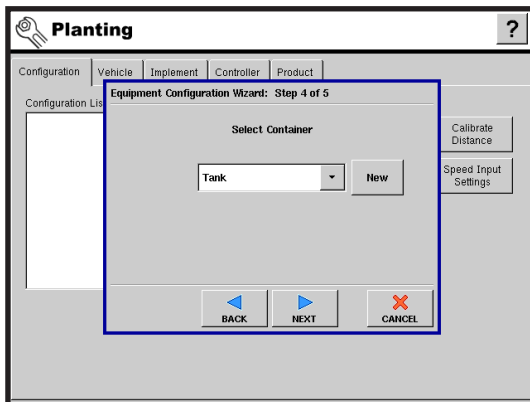

Select the container that will be used to hold the product being applied by the additional implement from the drop down list.

**NOTE:** If a new one must be created see *“Adding A New Vehicle”* on page 5-28.

Press **Next**.

### STEP 6 Edit Name

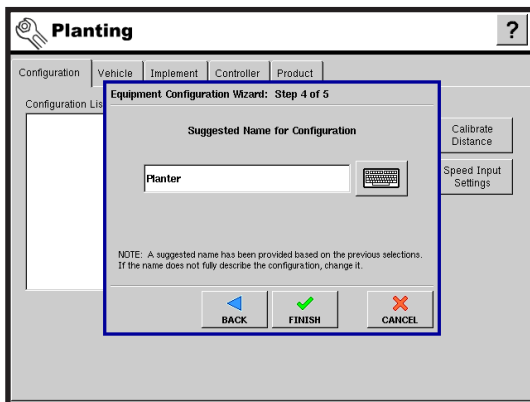

Use the keyboard button to edit the name of the configuration.

Press **Finish** to complete the setup process.

Press **Add** to add more implements and go back to step one.

If all the required implements are added press **Next**.

## CONFIGURATION SETTINGS

To access the equipment configuration settings screens first highlight a configuration in the list and then press the **Configuration Settings** button.

**NOTE:** If a site verification configuration with an implement switch is being used the only option available will be implement switch polarity.

### Equipment Configuration

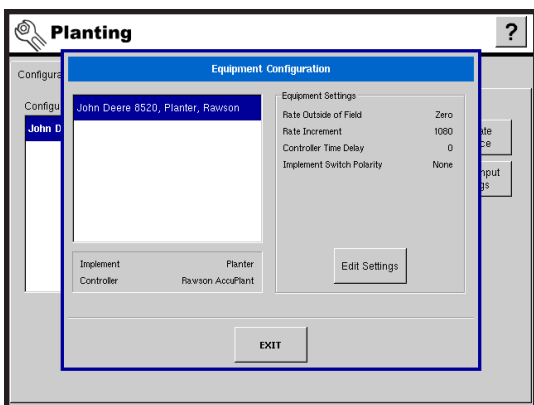

The window at left will display after selecting an operating configuration and pressing the **Configuration Settings** button. Implement and controller name for the configuration are displayed at the lower left on the dialog. Settings related to controller operation for the configuration are displayed on the right. Press **Edit Settings** to display detailed information or edit any of these settings.

### Equipment Configuration Settings

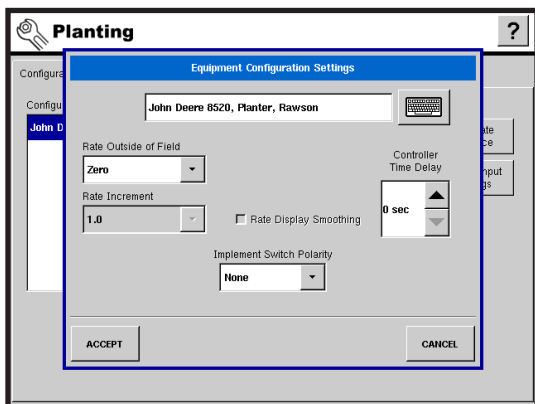

The configuration name can be changed by pressing the on-screen keyboard screen.

-The **Rate Outside of Field** selection as defined in the table below determines product control channel behavior when the field boundary is exited.

- **Zero** = Product application will turn off.
- **Last Good** = Product application will continue at the last value used by the control system.
- **TGT Default** = Product will be applied at the default rate setting

-The **Rate Increment** setting can be modified from the original value set during the controller configuration process. This setting determines the amount that the target application rate setting will change when the up or down arrow key is pressed on the target rate dialog at the run screen.

-The **Rate Display Smoothing** setting determines how the feedback from the control channel rate sensor will be displayed on the run screen. When de-selected, the system will display raw feedback from the rate sensor. When checked, the system will display target rate when the actual rate is within 10% of the target rate setting.

-The **Controller Time Delay** setting compensates for any latency in the control system when changing between different product flow rates during variable rate application. The typical setting range for this is 0 - 1 seconds.

## AUTOMATIC SWATH CONTROL SETTINGS

The **Automatic Swath Control** feature turns sections off and on automatically based upon the following conditions:

- Entering and exiting internal and outer field boundaries.
- Entering and exiting mapped product recommendation areas.
- Entering and exiting previously applied areas within a field.

To access the Automatic Swath Control settings, select the Configuration tab, and press the **Automatic Swath Control** button to access the related settings. These settings affect the automatic swath control operation and are specific to that combination of **Vehicle, Implement, and Controller**.

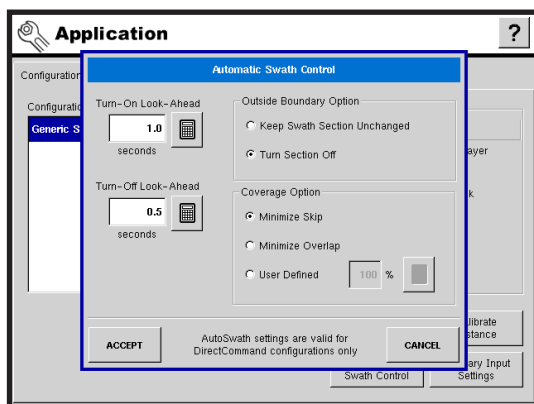

**Automatic Swath Control Settings**

Item	Description
<b>Turn-On Look-Ahead</b>	This setting determines how far ahead the system looks to turn the sections back on. This setting compensates for delay in the product control system when the implement sections are turned on. To see what these numbers should look like for Clutch Control Modules, see <i>“Clutch Control Look-Ahead Numbers” on page 5-21</i> .
<b>Turn-Off Look-Ahead</b>	This setting determines how far ahead the system looks to turn the sections off. This setting compensates for delay in the product control system when the sections are turned off. To see what these numbers should look like for Clutch Control Modules, see <i>“Clutch Control Look-Ahead Numbers” on page 5-21</i> .
<b>Outside Boundary Option</b>	Select one of the two options to determine system behavior when a section exits a field boundary or prescription mapped area.
<b>Coverage Option</b>	<p>In the Coverage Option area, you must choose between three options:</p> <ul style="list-style-type: none"> <li>• The <b>Minimize Skip</b> option turns off the implement section after the entire section is <i>fully inside</i> your coverage area. This prevents the possibility of skips.</li> <li>• The <b>Minimize Overlap</b> option turns off the implement section when that section first <i>enters</i> your coverage area. This prevents the possibility of overlaps.</li> <li>• The <b>User Defined</b> option allows you to choose what percentage of the implement section is within the coverage area before that section turns off. For example, if you choose <b>50%</b>, then the section will switch off when half of it is within your coverage area.</li> </ul>

## Clutch Control Look-Ahead Numbers

This table references the Turn-On, Look-Ahead and Turn-Off, Look-Ahead numbers for both Electric Clutch and Air Clutch Control Modules.

Seed Meter Type	ON/OFF	Electric Clutch	Air Clutch
Mechanical	ON	0.9	1.1
	OFF	0.3	0.3
Vacuum	ON	0.9	1.1
	OFF	0.4	0.4

**NOTE:** Using the above settings will produce accurate field results. However, small gaps may appear on the display, as in the example shown below left. These gaps do not reflect actual machine performance or log data.

**IMPORTANT:** If gaps appear within the on-screen map (see below):

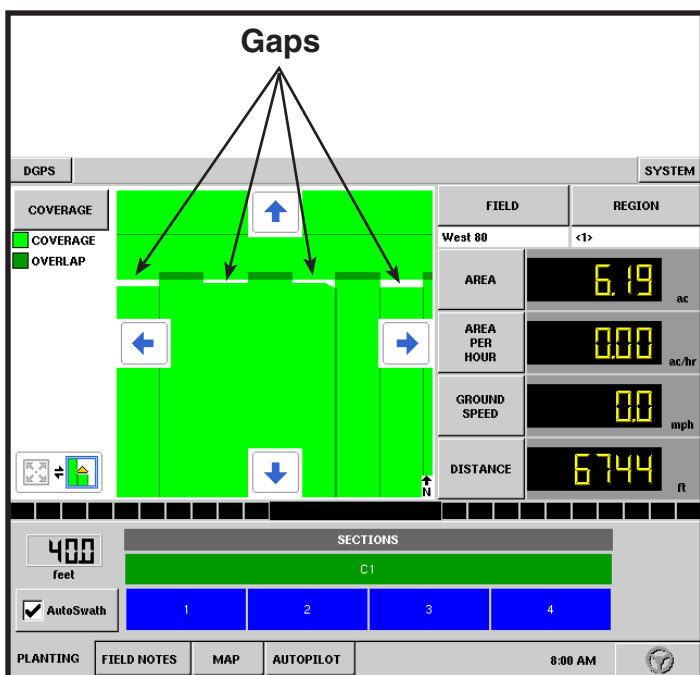

Typical Example of SeedCommand™ Coverage Map

When operating AutoSwath™, do not make changes to the look-ahead settings based on data from the on-screen map.

The look-ahead settings in the Planter Unit Seed Meter Type table were created from field testing and machine observations to determine the appropriate settings for each combination of clutch and seed meter. These should be accurate settings unless your planter has been modified. Small skips and overlaps in the map may be expected but should not require you to adjust settings without first observing your machine's performance.

To determine if a setting change is necessary, perform the procedure detailed in "Checking AutoSwath™ Performance for Clutch Control" on page 5-22 to observe the actual machine performance. Following this procedure will give you additional data to use with that already received from the on-screen map.

## Checking AutoSwath™ Performance for Clutch Control

The settings given in the AutoSwath™ look-ahead table have been tested with each clutch and seed meter combination to work for your planter. However, if you are looking for a method to verify the performance of SeedCommand, then you should attempt the following procedure:

- STEP 1** Stop the planter within 20 feet of the planted headland.
- STEP 2** Select one row unit from each planter swath section to observe.
- STEP 3** Remove the down pressure from the closing wheel of each selected row unit.
- STEP 4** Hold the closing wheels off the ground by attaching a chain or strap from the hopper support panel to the closing wheel arm. (This prevents the closing wheels from closing the seed trench).

**NOTE:** Securing these closing wheels up allows you to observe the planted seed in the trench so that you can observe when the KINZE Vision display is turned off and on during the seed application.

**STEP 5** Resume planting in your normal fashion, then stop when you are 20 feet out of the headland of the next pass.

**STEP 6** Stop the planter and observe the AutoSwath™ shutting off and turning on to see if the results are acceptable.

- If the results are correct, then return the closing wheels to their previous operational state. Close the seed trench on the observed rows and return to planting.
- If you suspect the results are incorrect, then adjust the appropriate look-ahead setting one-tenth (0.1) second per trial. When making changes to the look-ahead settings, make sure to adjust these settings only one-tenth (0.1) second per trial. Larger adjustments can cause unintentional large changes in the AutoSwath's performance.

**NOTE:** When adjusting the look-ahead numbers from the suggested settings, it is recommended that you observe multiple trials to confirm the accuracy of the operation.

## CALIBRATE DISTANCE

Select a **Configuration** from the list and press the **Calibrate Distance** button to calibrate the radar, track or wheel speed sensor. This calibration is specific to that combination of **Vehicle**, **Implement**, and **Controller**. The Speed Sensor Calibration wizard appears, as shown below.

### STEP 1 Select Speed Input

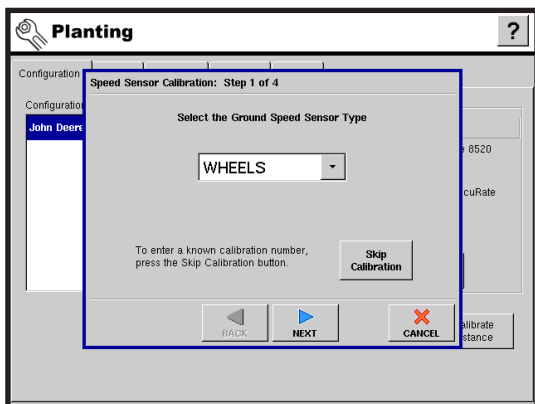

Select the sensor type to calibrate and press **NEXT** to continue.

### STEP 2 Calibration Distance

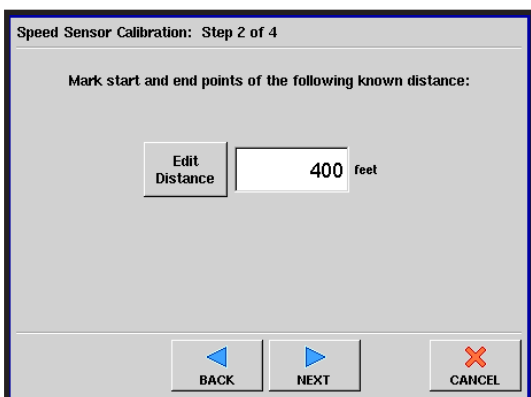

The system defaults to 100 feet (50 meters) distance for calibration.

Press **Edit Distance** to change if needed. This value must match the actual distance of the course driven for calibration.

Press **NEXT** to continue.

### STEP 3 Start Driving Course

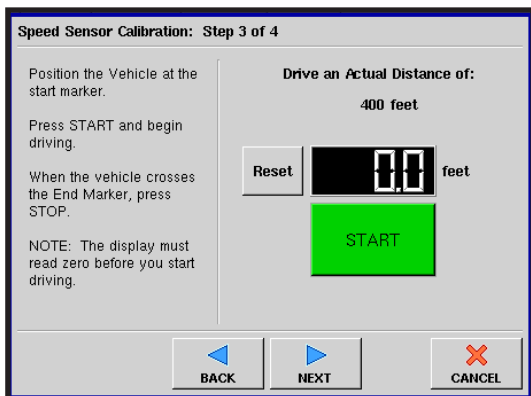

Follow the on-screen directions and press **START** to begin the calibration process.

## CALIBRATE DISTANCE (Continued)

### STEP 4 Course Completed

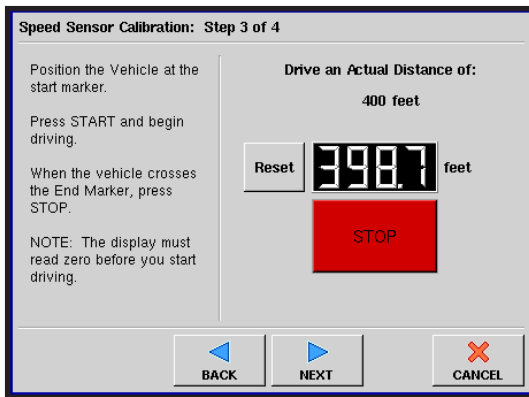

Drive vehicle over the measured course and press **STOP**.

Press **NEXT** to continue to final step.

### STEP 5 Calibration Completed

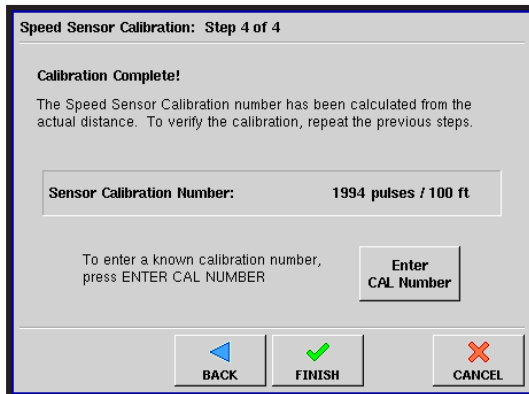

Press **FINISH** to complete calibration and store the calculated value.

**NOTE: Calibration settings can be manually adjusted if desired by pressing Enter CAL Number and making small changes to the setting.**

## AUXILIARY INPUT SETTINGS (SWITCH MAPPING)

The Auxiliary Input Settings feature, (also called “Switch Mapping”) allows you to specify which switches on a Smart Switch Box can control the boom sections of your implement. This process is used for and SeedCommand configurations. (It is not used for serial controllers or site verification scenarios).

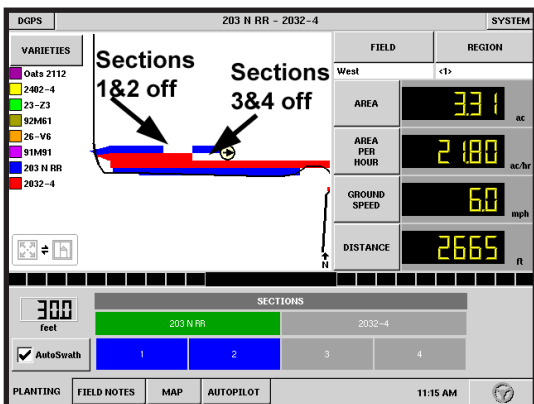

The example at left shows Switch Mapping at work in the field. In this instance, the operator is planting two varieties using an implement with four boom sections. The operator has used the Auxiliary Input Settings window, shown below, to map the switches so that switch 1 controls sections 1 and 2; and switch 2 controls sections 3 & 4.

As the vehicle travels to the right of the screen, the operator first used switch 1 to turn off sections 1 and 2; then the operator used switch 2 to turn off sections 3 and 4.

### Auxiliary Input Settings Window

The Auxiliary Input Settings window appears when you press the **Auxiliary Input Settings** button. This Switch Mapping function is active only for users with or the Planting Clutch Control features.

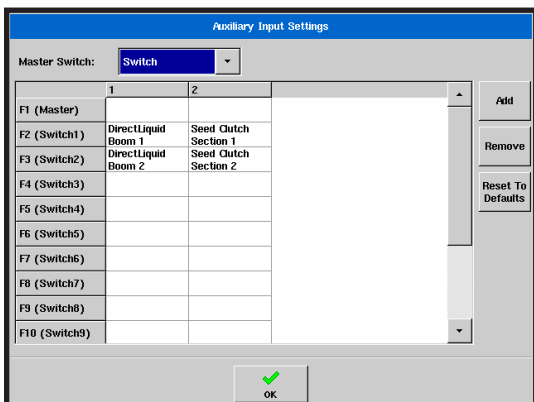

The Auxiliary Input Settings window, shown at left, displays settings for the Master Switch and other switches on a Smart Switch Box.

The Master Switch drop down menu, shown at the top, controls the master switch for your entire configuration. You may see the following options underneath this menu:

- **Switch** - Controls the master switch.
- **External 2** - This setting can control an optional, floor-mounted master switch.
- **External 1, 3 and 4** - Not used at this time.

The F1-F10 cells on the left can be assigned to any implement sections. You can use these to choose the switches that control a particular implement or planting clutch. From here, you can also make the following changes to the switch settings.

- Add a switch setting (see below).
- Remove a switch setting.
- Reset to default switch settings.

## Add Auxiliary Input Settings

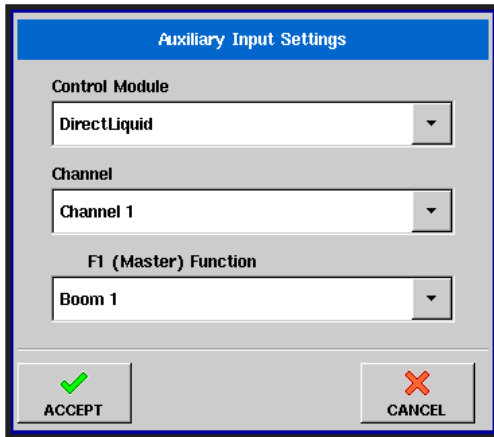

The screenshot shows a dialog box titled "Auxiliary Input Settings". It features three dropdown menus. The first is labeled "Control Module" and has "DirectLiquid" selected. The second is labeled "Channel" and has "Channel 1" selected. The third is labeled "F1 (Master) Function" and has "Boom 1" selected. At the bottom of the dialog, there are two buttons: "ACCEPT" with a green checkmark icon and "CANCEL" with a red X icon.

If you wish to add a switch setting, press the **Add** button, and a second Auxiliary Input Settings window appears, as shown at left. This window shows the following drop down menus:

- **Control Module** - Specifies the function of your SeedCommand or Planting Clutch Control.(For example, Spinner Spreader or Granular Strip Till controller).
- **Channel** - Select the channel to control. Used for Strip Till or Spinner Spreader modules.
- **F1 (Master) Function** - Turns the implement section on and off.



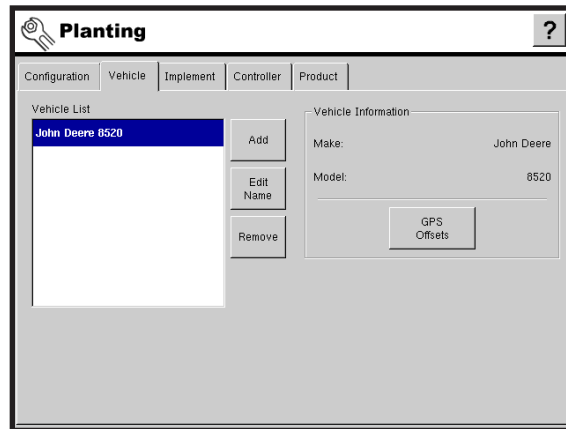

## VEHICLE TAB SETTINGS

The vehicle tab provides functionality for setting up and configuring additional vehicles. The vehicle list will show any vehicles that have already been created.

To see a Planting Menu that includes vehicle information, see *“SeedCommand™ Menu Tree” on page 7-3.*



**Vehicle Setup Tab**

Button	Description
	The <b>Add</b> button allows you to add a new vehicle. A wizard will walk you through setting up the vehicle. For detailed information, see <i>“Adding A New Vehicle” on page 5-28.</i>
	The <b>Edit Name</b> button allows you to edit the name of a vehicle in the list. To edit, highlight the name of a vehicle in the list and then press this button. Then use the on-screen keyboard to edit the name.
	The <b>Remove</b> button allows you to remove a vehicle. The implement and any regions and configurations using it will be deleted.  <b>IMPORTANT: When deleting a vehicle, all regions and configurations using it will be deleted.</b>
	The <b>GPS Offsets</b> button allows you to specify the location of the GPS antenna in relation to the vehicle. A wizard will walk you through these edits. It also allows you to enter the distances from the rear axle to the different implement mounting positions on the tractor. See <i>“GPS Offsets” on page 5-29.</i>

## ADDING A NEW VEHICLE

To start the process of adding a new vehicle press the **Add** button.

### STEP 1 Enter Vehicle Make And Model

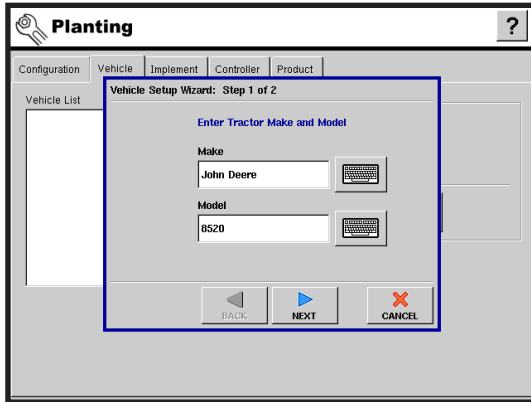

Use the keyboard buttons to enter the vehicle's make and model.

Press **Next**.

### STEP 2 Edit Vehicle Name

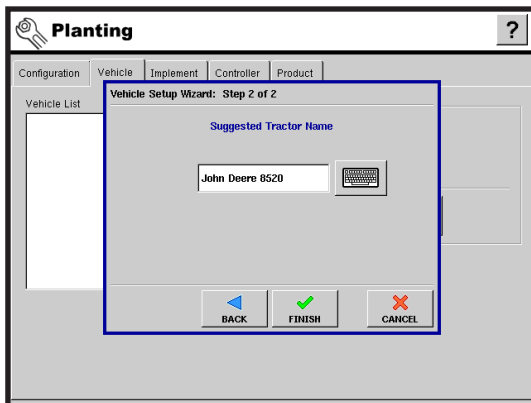

Use the keyboard button to edit the name of the vehicle.

Press **FINISH** to complete the setup process.

# CONFIGURATION VEHICLE TAB - ADVANCED SETTINGS

## GPS OFFSETS

After completing the process of setting up a Vehicle, advanced GPS Offsets must be configured. The GPS Offsets define where machine rear axle, hitch, and product placement is in relation to the GPS antenna. These settings are used by mapping, product control, and Automatic Swath Control.

### Antenna Offsets

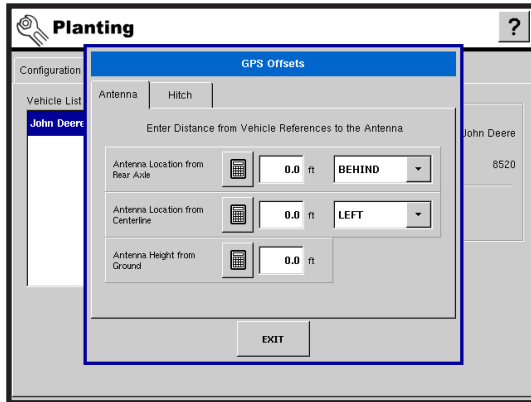

The Antenna Tab contains three different settings. Accuracy when measuring for a specific setting is essential to ensure proper machine performance.

- Measure and enter the horizontal distance from the rear axle to the position of the GPS antenna. Select **IN FRONT** or **BEHIND** from the list box to indicate the position of the antenna in relation to the rear axle.
- Measure and enter the horizontal distance from the centerline of the vehicle to the position of the GPS antenna. Select **LEFT** or **RIGHT** to indicate the position from the vehicle centerline.
- Measure and enter the vertical height of the antenna above the ground.

### Hitch Tab Settings

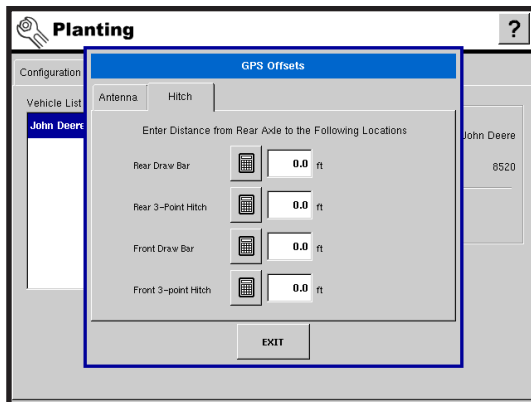

The hitch tab allows you to enter in the distance from four different mounting positions on the tractor to the rear axle. Use the Number Pads to enter these values in if using the hitch point.

**NOTE: Accuracy when measuring for a specific setting is essential to ensure proper machine performance.**



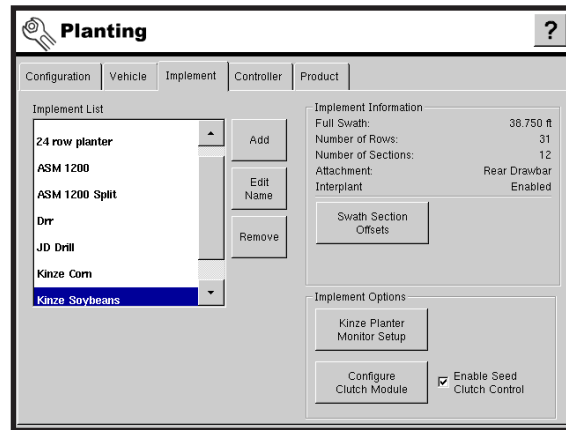

## IMPLEMENT TAB SETTINGS

Individual implements are set up and configured from the Implement Tab. The implement list displays all previously set up implements that are available for use when creating new configurations.

To see a Planting Configuration Menu that includes Implement Tab settings, see “SeedCommand™ Menu Tree” on page 7-3.

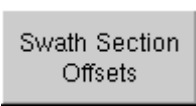

**Implement Configuration Tab**

Button	Description
	Press to add a new implement. A wizard will walk you through setting up the implement. For detailed information, see “Adding A New Implement” on page 5-32.
	Press to edit the name of a selected implement from the list. The on-screen keyboard will be made available to make any required edits.
	Press to remove a selected implement. <b>IMPORTANT: When deleting an implement, all regions and configurations using it will be deleted.</b>
	Press to edit the swath section offsets, distance from tractor hitch to application point, and distance from front hitch to rear hitch of the implement. An on-screen wizard will walk you through the edit process. For detailed information see “Swath Section Offsets” on page 5-35.
	Allows the operator to adjust configuration settings for the Planter, Sensor and Alarms. For more information, see “KINZE® Planter Monitor Setup” on page 5-37.

## IMPLEMENT TAB SETTINGS (Continued)

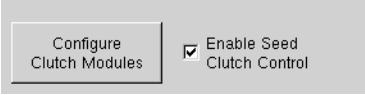
	<p>The Enable Seed Clutch Control check box allows you to configure a Clutch Control Module, which is a function of SeedCommand.</p> <p><b>NOTE: You must have the Enable Clutch Control Module check box selected in order to have the Configure Clutch Control button enabled.</b></p> <ul style="list-style-type: none"><li>• For step-by-step information on configuring the Clutch Control Modules, see <i>“SeedCommand™ Clutch Control Configuration”</i> on page 5-66; and more specifically, see <i>“STEP 8”</i> on page 5-68</li></ul>
---	---

## ADDING A NEW IMPLEMENT

This procedure describes how to set up an implement configuration for a generic planter. KINZE Vision Planter Control System users should see “SeedCommand™ KINZE® Planter Monitor Configuration” on page 5-60; and Clutch Control users should see “SeedCommand™ Clutch Control Configuration” on page 5-66.

To add a new implement press the Add button. The Implement Setup Wizard appears, as shown below.

### STEP 1 Select Attachment Method And Planter/Seeder Type

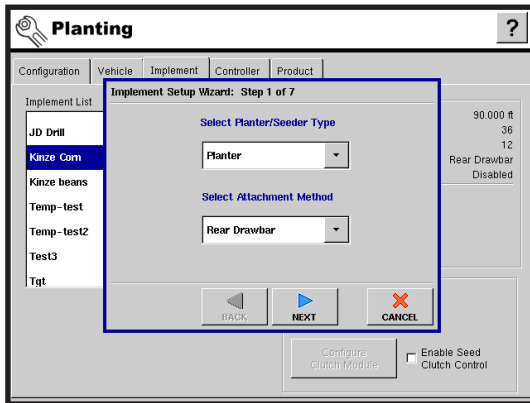

From the top drop down menu, select either Planter or Seeder/Drill. Then use the bottom drop down menu to select either Rear Drawbar or Rear 3-Point Hitch.

Press **Next** to continue.

### STEP 2 Select Implement Options

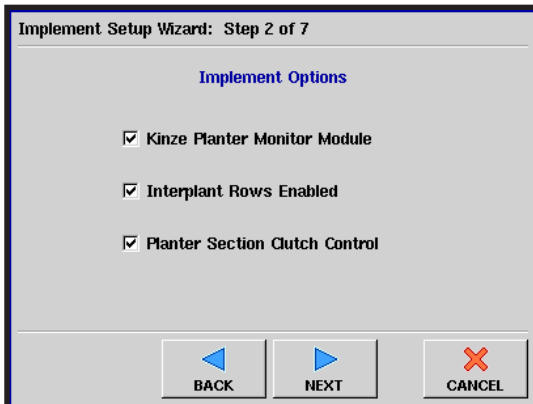

Select the following options, depending upon your desired configuration:

- **KINZE Planter Monitor Module** - Check this box to enable the KINZE Vision planter monitor functions.
- **Interplant® Rows Enabled** – Check this box to enable to log data from a KINZE planter's Interplant® push row units.
- **Planter Section Clutch Control** – Check this box to enable the SeedCommand planter clutches.

Press **Next** to continue.

### STEP 3 Enter Number Of Rows And Spacing

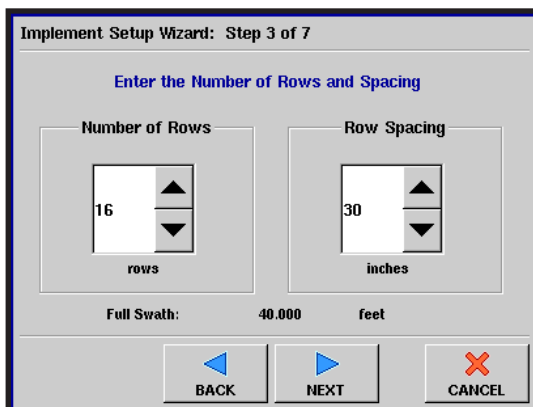

Use the up and down arrow keys to enter the number of rows and their spacing.

Press **Next** to continue.

## ADDING A NEW IMPLEMENT (Continued)

### STEP 4 Enter Number Of Implement Sections

Implement Setup Wizard: Step 4 of 7

Enter Number of Implement Sections

4

NOTE: DO NOT enter the number of individual rows. Enter the number of swath sections that can be independently turned on and off.

BACK NEXT CANCEL

Use the up and down arrow keys to enter the number of sections on the implement.

Press **Next** to continue.

**NOTE: Do not enter the number of individual rows. Enter the number of swath sections that can be independently turned ON and OFF.**

### STEP 5 Enter Section Widths From Left To Right

Implement Setup Wizard: Step 4 of 6

Enter Section Widths from Left to Right

Section	Swath Width (ft)
1	10.00
2	10.00
3	10.00
4	10.00

BACK NEXT CANCEL

For implements with more than one swath section, the system will default to the appropriate number of equal width swath sections. To edit any of the swath values, select the desired section from the list and press the number pad to enter in a new width.

Press **Next** to continue.

### STEP 6 Enter Distance From Hitch To Application Point

Implement Setup Wizard: Step 5 of 6

Enter Distance from Hitch to Application Point (front to back)

21.50  
feet

BACK NEXT CANCEL

Enter the distance from the hitch to the application point using the number pad button.

Press **Next** to continue.

## ADDING A NEW IMPLEMENT (Continued)

### STEP 7 Enter The Implement Name

Implement Setup Wizard: Step 6 of 6

Enter Implement Name

Planter

BACK FINISH CANCEL

Use the keyboard button to enter a name for the implement.

Press **Finish** to complete the implement setup process.

## SWATH SECTION OFFSETS

After completing the initial process of configuring an **Implement**, accurate values must be entered in the **Swath Section Offsets** to ensure proper machine performance. **Swath Section Offsets** are configured as outlined in the following steps.

### STEP 1 Select Section

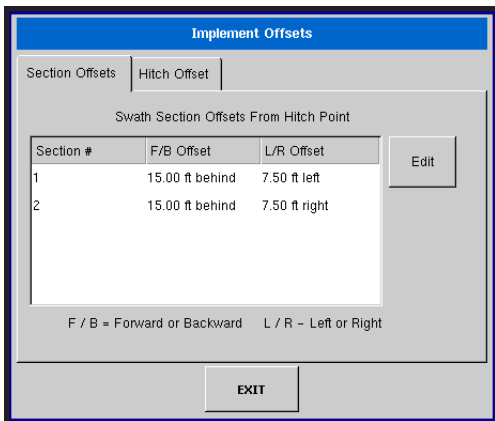

Select the desired section from the list and press **Edit** to modify the offset values.

### STEP 2 Enter Left-To-Right Distance From Hitch Point

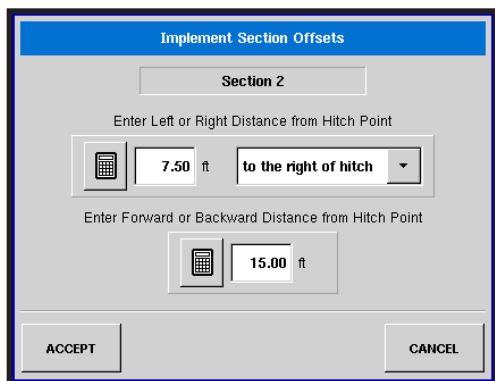

Use the keypad to enter the distance the mid-point of the swath section is from the machine centerline. Select **to the left of hitch** or **to the right of hitch** to indicate the direction the swath section is located from the vehicle centerline.

Enter the distance that the swath section is located from the hitch point.

Press **Accept** when done.

### STEP 3 Enter distance from front hitch to rear hitch

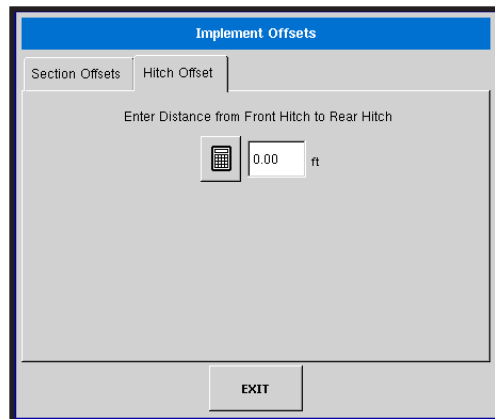

Use the numeric keypad to enter the distance from front hitch, if present, to rear hitch point. (This option will not be present on self-propelled vehicles.)

Press **Exit** when done.

**IMPORTANT: Accuracy when measuring and entering swath section GPS offsets is required to ensure proper machine performance.**

The KINZE Planter Monitor is a feature that receives planting data from a KINZE Population Monitor on the KINZE Vision run screen. If you have purchased the KINZE Population Monitor product, you should configure it in the following order.

**NOTE: Steps 1-4 must be performed by everyone who has purchased a KINZE Planter Monitor; steps 5-6 are performed by customers who have purchased those specific features.**

## **STEP 1 Implement Setup For The KINZE Vision Display**

This creates a KINZE Vision configuration that is used for KINZE Planter Monitor operations. See *“Adding A New Implement”* on page 5-32, especially the part of the procedure at “STEP 2” on page 5-32.

## **STEP 2 Planter Configuration Setup**

This includes front and rear unit settings, shaft RPM sensor settings and row spacing settings. This step allows the KINZE Vision display to detect the physical KINZE Planter devices. To begin, see *“KINZE® Planter Monitor Setup”* on page 5-37 and then continue on to *“KINZE® Planter Configuration”* on page 5-38.

## **STEP 3 Muxbus Sensor Detection Process**

This allows the KINZE Vision display to detect the proper number of muxbus sensors on the row units. See *“KINZE® Planter Monitor Muxbus Sensor Detection”* on page 5-43.

## **STEP 4 Set Alarm Thresholds**

This allows you to determine the level at which the seed monitor alarms will sound. See *“KINZE® Seed Monitor Alarms”* on page 5-47.

## **STEP 5 Calibrate The Magnetic Pickup Coil**

This step, which is performed by customers who have purchased the Magnetic Pickup Coil Speed Sensor allows the KINZE Vision display to receive accurate data from this sensor, which measures the ground speed of the planter. See *“KINZE® Magnetic Coil Speed Sensor Calibration”* on page 5-48.

## **STEP 6 EdgeVac® Calibration**



This step, which is performed by customers who have purchased the EdgeVac seed meters, allows the KINZE Vision display to receive accurate data from the meters. See *“KINZE EdgeVac® Calibration”* on page 5-50.

## KINZE® PLANTER MONITOR SETUP

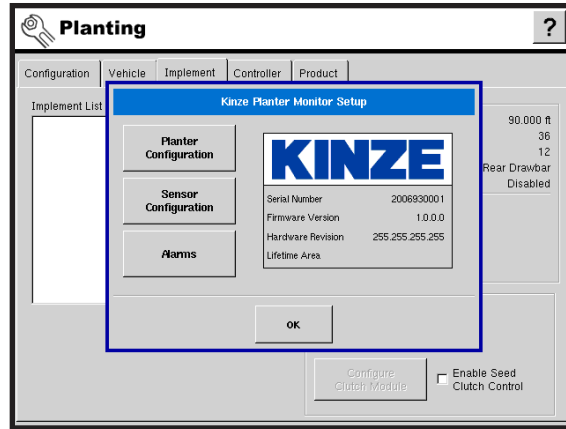
The **Planter Monitor Setup** button, located on the Implement tab, allows the operator to adjust configuration settings for the Planter, Sensor and Alarms. When this button is pressed, the KINZE Planter Monitor Setup window appears, as shown below.



**KINZE Planter Monitor Setup**



Item	Description
	<p>The <b>Planter Configuration</b> button opens the Planter Configuration window.</p> <p>For more information, see “KINZE® Planter Configuration” on page 5-38.</p>
	<p>The <b>Sensor Configuration</b> button shows the Sensor Configuration window.</p> <p>For more information, see “KINZE® Planter Sensor Configuration” on page 5-41.</p>
	<p>The <b>Alarms</b> button pulls up the Seed Monitor Alarms window, where the operator can set a threshold for the alarm at 10%, 50%, or 70% or a user-specified percentage; or disable the alarm entirely.</p> <p>For more information, see “KINZE® Seed Monitor Alarms” on page 5-47; see also “Alarms on KINZE® Planter Monitor” on page 6-23.</p>

## KINZE® PLANTER CONFIGURATION

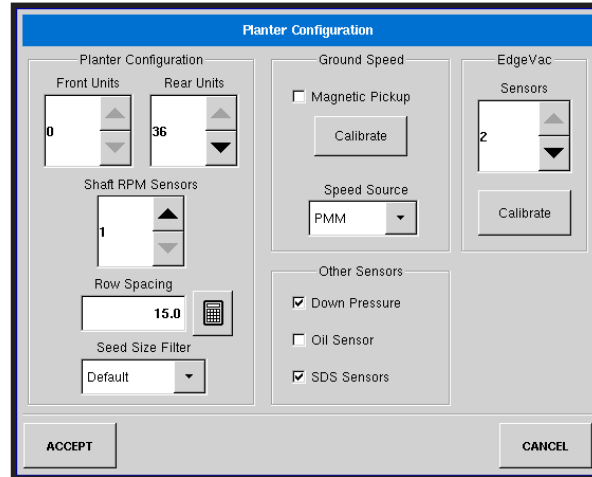

To view the Planter Configuration window, go to the Implement Tab, press the **KINZE Planter Monitor Setup** button, and when the KINZE Planter Monitor Setup window appears, press the **Planter Configuration** button.

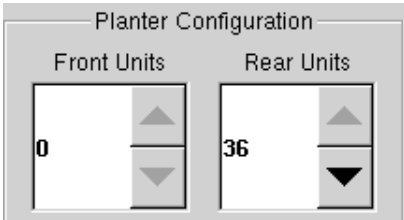
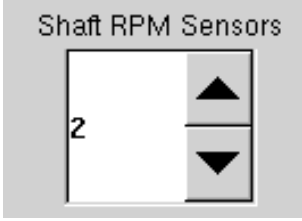

**KINZE Planter Configuration Window**

Setting	Description
	<p>Use the up and down arrow keys to adjust the number of front and rear planting units, if necessary.</p>
	<p>Use the up and down arrows to adjust the number of <b>Shaft RPM Sensors</b>, if necessary.</p>
	<p>The <b>Row Spacing</b> window shows the minimum row spacing of the planter. Use the numeric keypad to adjust the Row Spacing.</p>

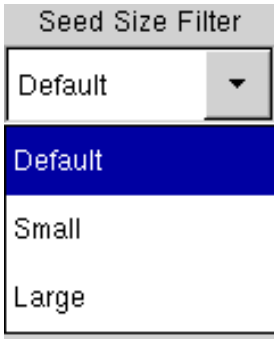
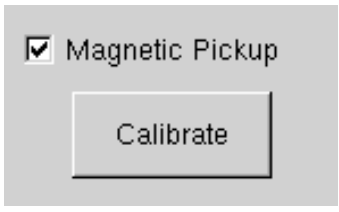
## KINZE® PLANTER CONFIGURATION (Continued)

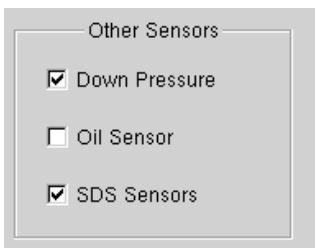
Setting	Description
	<p>The Seed Size Filter drop down box should be left at the default setting.</p>
	<p>Check the <b>Magnetic Pickup</b> check box only if the planter is equipped with the Magnetic Pickup Sensor. This setting should then be left unchanged. For information on calibrating the Magnetic Coil Speed Sensor, see “KINZE® Magnetic Coil Speed Sensor Calibration” on page 5-48.</p> <p><b>NOTE: Customers who do not have the magnetic pickup sensor who check this box will see a window stating “Bad Configuration: No Magnetic Pickup sensor currently found.”</b></p>
	<p>The <b>Speed Source</b> drop down box selects the type of speed source for the planter monitor. It includes the following options:</p> <ul style="list-style-type: none"> <li>• GPS</li> <li>• Auxiliary (Smart Switchbox)</li> <li>• Planter Monitor Module (PMM)</li> </ul> <p><b>NOTE: This speed selection only affects the PMM. The KINZE Vision ground speed source must still be selected.</b></p>
	<p>Other check boxes on the Planter Configuration window include:</p> <ul style="list-style-type: none"> <li>• <b>Down Pressure</b> - Check this box if the planter has pneumatic down pressure.</li> <li>• <b>Oil Sensor</b> - Leave this box unchecked.</li> <li>• <b>SDS Sensors</b> - Check this box if the planter has a mechanical Seed Distribution System (SDS) installed.</li> </ul> <p><b>NOTE: The above functions only work with the KINZE Vision Planter Control System if equipped with Muxbus sensors.</b></p>

## KINZE® PLANTER CONFIGURATION (Continued)

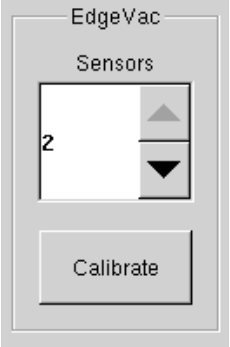
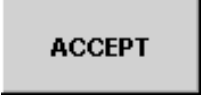

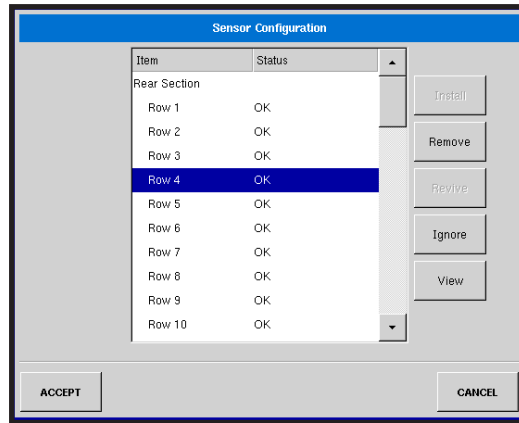

Setting	Description
	<p>Use the arrows to enter the number of EdgeVac sensors on your planter.</p> <p>You will also need to calibrate the EdgeVac sensors once per year. To start this process, press the <b>Calibrate</b> button. For more information, see “<i>KINZE EdgeVac® Calibration</i>” on page 5-50.</p>
	<p>To save configuration settings, press the <b>Accept</b> button.</p> <p><b>NOTE: If you have changed the number of sensors on the Planter configuration, the Accept button starts the Muxbus Detection procedure. For more information, see “<i>KINZE® Planter Monitor Muxbus Sensor Detection</i>” on page 5-43.</b></p>

## KINZE® PLANTER SENSOR CONFIGURATION



To view the Sensor Configuration Window, go to the Implement Tab, press the **KINZE Planter Monitor Setup** button, and when the KINZE Planter Monitor Setup window appears, press the **Sensor Configuration** button. The Sensor Configuration window, shown below, is for system maintenance of the KINZE Population Monitor.



**Sensor Configuration Window**

Button	Description
	<p>The <b>Install</b> button installs a row sensor.</p> <p><b>NOTE:</b> Upon your initial configuration of the KINZE Planter Monitor, you must complete the <b>Sensor Muxbus Detection</b> process. For more information, see “KINZE® Planter Monitor Muxbus Sensor Detection” on page 5-43.</p>
	<p>The <b>Remove</b> button removes the highlighted sensor of any type.</p>
	<p>The <b>Revive</b> button allows the display to reattempt communication with the highlighted sensor of any type.</p>
	<p>The <b>Ignore</b> button tells the display to cease communications with a row sensor.</p>

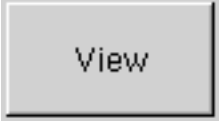
**KINZE® PLANTER SENSOR CONFIGURATION (Continued)**

<b>Button</b>	<b>Description</b>
 A rectangular button with a light gray background and a thin black border. The word "View" is centered in a black sans-serif font.	The <b>View</b> button shows the Sensor Information window. For further information, see <i>"KINZE® Planter Monitor Sensor Information"</i> on page 5-46.
 A rectangular button with a light gray background and a thin black border. The word "ACCEPT" is centered in a bold black sans-serif font.	The <b>Accept</b> button saves configuration settings.

## KINZE® PLANTER MONITOR MUXBUS SENSOR DETECTION

Upon your initial configuration of the KINZE Planter Monitor, you must complete the Sensor Muxbus Detection process. This process allows the muxbus to detect each sensor on the planter. In order for the display to show the correct Planter Monitor information, you must complete the detection process for each muxbus sensor.

**NOTE: Make sure that all of your sensors are unplugged before you begin the Muxbus Detection process. If any of your sensors are still plugged in, the Muxbus Detection process will abort. If this occurs, unplug the remaining sensors and retry the procedure.**

To start the Sensor Muxbus Detection process, go to the Implement Tab, press the **KINZE Planter Monitor Setup** button, and when the KINZE Planter Monitor Setup window appears, press the **Planter Configuration** button. The Planter Configuration window appears, as shown below.

### STEP 1 Press Accept on Planter Configuration Window

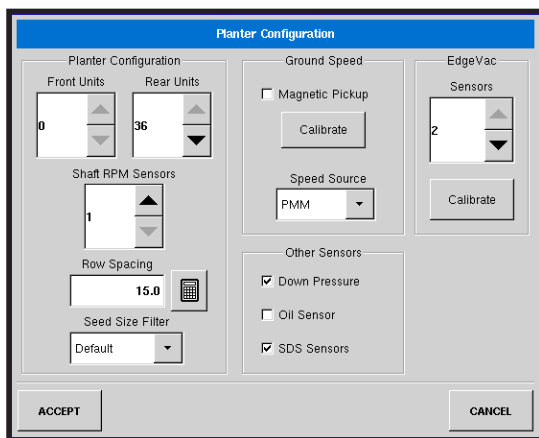

When the Planter Configuration window appears, make any changes to the Planter Configuration Settings that are necessary. For more information on these settings, see “KINZE® Planter Configuration” on page 5-38.

When you are finished making adjustments to the settings, press **Accept**.

**NOTE: The Muxbus detection process will only start if you have changed the sensor configuration. If you have not changed your configuration, it will not repeat the muxbus detection process but instead will exit to the Implement tab.**

### STEP 2 Accept the Muxbus Detection

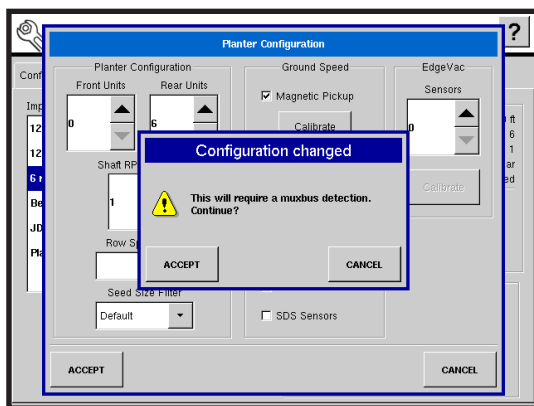

A window appears, informing you that your configuration has changed and that it will require a muxbus detection. Press the **Accept** button on the Configuration Changed window. The Muxbus Detection Process then begins.

## KINZE® PLANTER MONITOR MUXBUS SENSOR DETECTION (Continued)

### STEP 3 Detect Individual Row Units

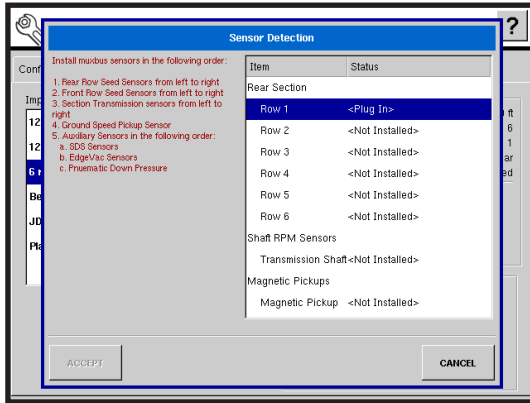

Plug in each physical sensor plug into the muxbus wiring harness on the planter (from left to right), and press **Accept** for each one. Follow the on-screen instructions, which are reproduced here:

Install the muxbus sensors in the following order:

1. Rear Row Seed sensors from left to right
2. Front Row Seed sensors from left to right
3. Section Transmission sensors from left to right
4. Ground Speed Pickup Sensor
5. Auxiliary Sensors in the following order:
  - a. SDS Sensors
  - b. EdgeVac Sensors
  - c. Pneumatic Down Pressure

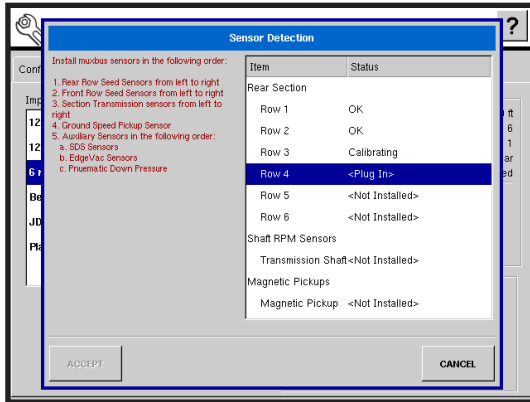

### STEP 4 Resolve Any Possible Errors

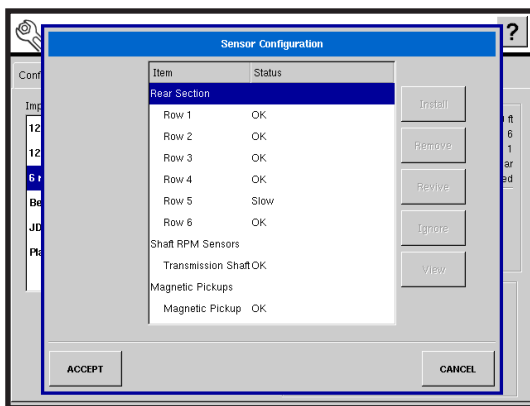

When the Muxbus Detection Process begins, each row unit will display “N/A” (not available) underneath the status. But as the Muxbus Detection process takes place, each row unit should state “Calibrating” for a time, then should indicate “OK”, as in the case of Row Units 1-4 and Row Unit 6, shown at left.

After calibration, the sensor status displays either one of two different states:

- **OK** - The sensor is working and is communicating at 9600 baud.
- **Slow** - The sensor is working, but is communicating at 2400 baud.

**NOTE: Older KPM I and KPM II systems have slower sensors that communicate at 2400 baud.**

The KINZE Vision display will beep once when the row unit sensor is plugged in, and will beep again when calibration is complete.

MUXBUS SENSOR DETECTION (Continued)

STEP 5 Detect Complete

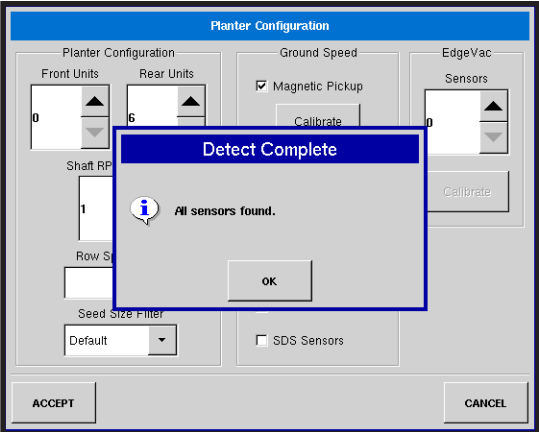

When the Muxbus Detection process is complete, a message displays, stating “All sensors found” as shown at left.

## KINZE® PLANTER MONITOR SENSOR INFORMATION

The Sensor Information window displays hardware information for each seed tube sensor. Technical support may request that you look at this window to help in diagnosing a problem. To view the Sensor Information window, go to the Implement Tab, press the **KINZE Planter Monitor Setup** button, and when the KINZE Planter Monitor Setup window appears, press the **Sensor Configuration** button. When the Sensor Configuration window appears, press the **View** button.

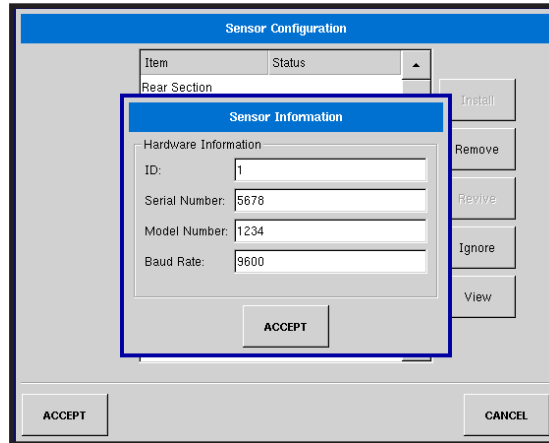

**Sensor Information Window**

Item	Description
<b>ID</b>	The hardware <b>ID</b> number is a unique number for each sensor on the muxbus.
<b>Serial Number</b>	The <b>Serial Number</b> varies for each individual unit of and seed tube sensor.
<b>Model Number</b>	The <b>Model Number</b> is shared by each unit of the same model of seed tube sensor.
<b>Baud Rate</b>	The <b>Baud Rate</b> number is the speed of transmission between the muxbus sensor and the PMM module.

## KINZE® SEED MONITOR ALARMS

To view the Seed Monitor Alarms window, go to the Implement Tab, press the **KINZE Planter Monitor Setup** button, and when the KINZE Planter Monitor Setup window appears, press the **Alarms** button. For more information, see “Alarms on KINZE® Planter Monitor” on page 6-23.

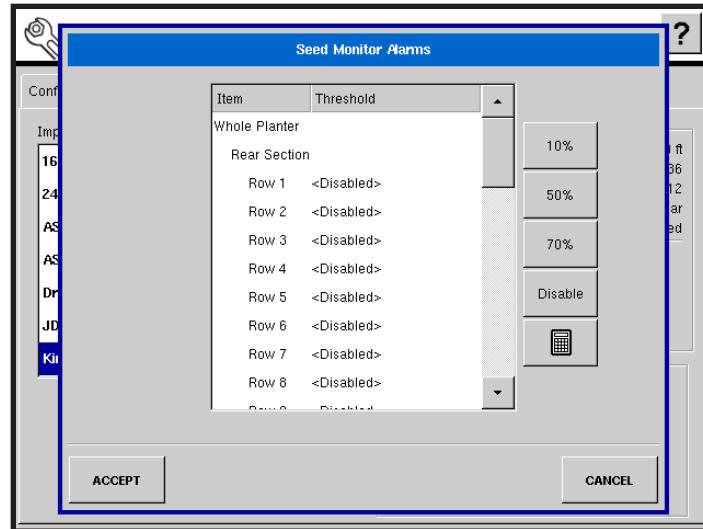

**Seed Monitor Alarms**

You can change the alarm threshold for each individual row unit, or for an individual section, or the whole planter. To change the threshold of an alarm, highlight the row unit, then press either a given percentage number (**10%**, **50%**, **70%**, or use the numeric keypad to create your own value). The alarm will then sound only when the population drops below that numeric threshold value.

**NOTE: The default alarm setting is at 50%.**

If you wish to turn the threshold of the alarm to zero, press the **Disable** button.

## KINZE® MAGNETIC COIL SPEED SENSOR CALIBRATION

KINZE Planter Monitor customers who have a magnetic coil speed sensor must check the Magnetic Pickup check box on the Planter Configuration window when the first enter a configuration. This setting should then be left unchanged. For reference, see “KINZE® Planter Configuration” on page 5-38 and the settings described on the following page.

These customers will need to calibrate the Magnetic Coil Speed Sensor at least once per season. To do this, go to the Implement Tab, press the **KINZE Planter Monitor Setup** button, and press the **Planter Configuration** button. When the Planter Configuration window appears, press the **Calibrate** button. The Magnetic Coil Speed Sensor Calibration wizard appears, as shown below.

### STEP 1 Enter Distance Of Calibration

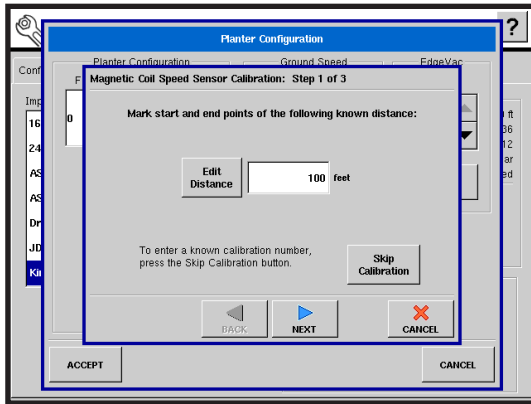

The default distance for calibrating the magnetic coil speed sensor is 100 feet (50 meters). If you wish to calibrate at another distance, enter the new distance.

Press **Next** to continue.

### STEP 2 Drive From Start To End Points

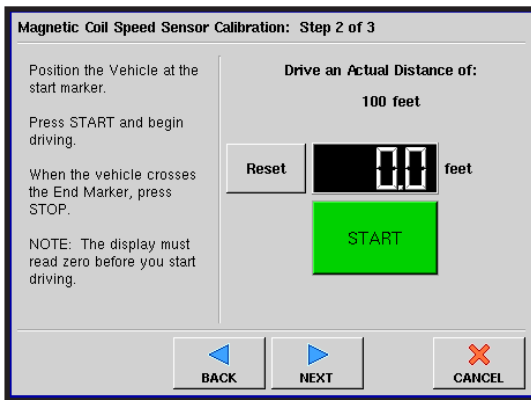

Position the vehicle at the start marker. Press the green-colored **Start** button and drive the vehicle for the predetermined distance.

**NOTE: The KINZE Vision display must be set on 0.0 before you begin driving the calibration distance.**

Press **Next** to continue.

## MAGNETIC COIL SPEED SENSOR CALIBRATION (Continued)

### STEP 3 Stop At End Of Calibration Distance

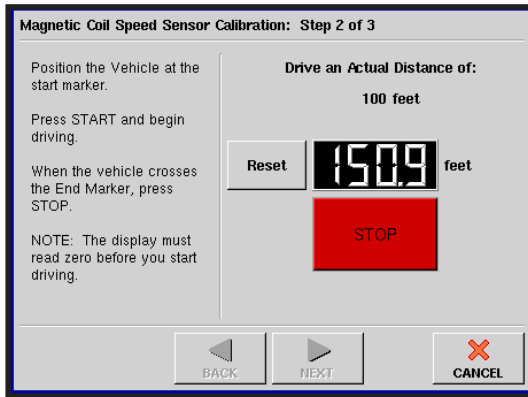

When the vehicle crosses the end marker of the predetermined distance, press the red-colored **Stop** button.

Press **NEXT** to continue to final step.

### STEP 4 Calibration Complete

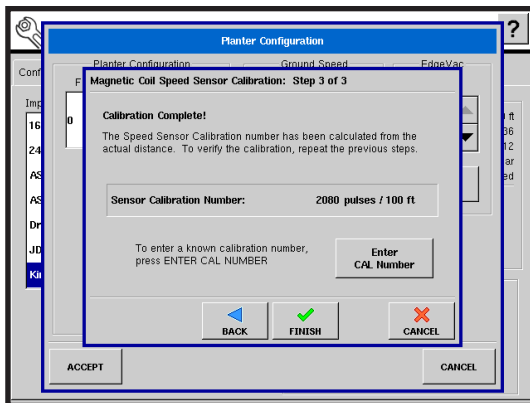

The speed sensor calibration number has been calculated from the actual distance driven.

Press **FINISH** to complete calibration and store the calculated value.

**NOTE:** Calibration settings can be manually adjusted if desired by pressing Enter CAL Number and making small changes to the setting.

**NOTE:** To verify the calibration, repeat the previous steps.

## KINZE EDGEVAC® CALIBRATION

Customers who have purchased the EdgeVac seed meters should perform an EdgeVac Calibration once a year to make sure that it is correct. Use the numeric keypad to enter the actual value taken from the hand-held calibration device at row unit.

**NOTE: Enter the level of vacuum measured at the row unit. Measurements should be taken with fans on and seed meter charged.**

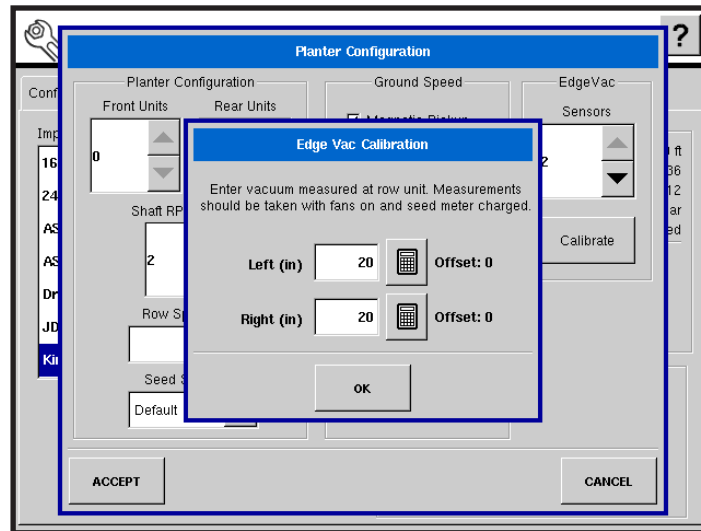

EdgeVac® Calibration Window



## CONTROLLER TAB SETTINGS

Use the controller tab to add and configure controllers for use during planting.

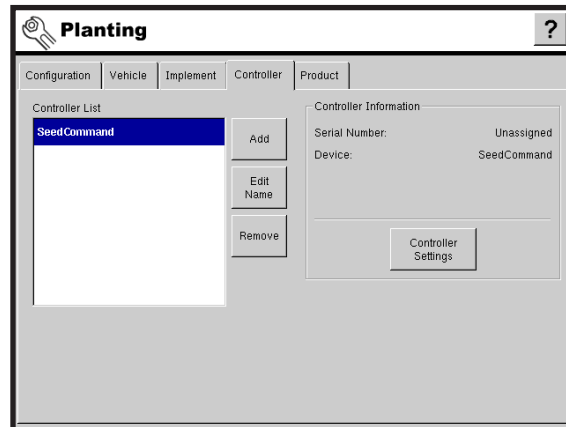
To see a Planting Configuration Menu that includes Controller Tab settings, see “SeedCommand™ Menu Tree” on page 7-3.

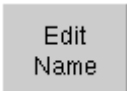

**Controller Configuration Tab**

Button	Description
	Press to add a new controller. A wizard will walk you through setting up the controller. For detailed information, see “Adding A New Controller” on page 5-53.
	Press to edit the name of a selected controller from the list. The on-screen keyboard will be made available to make any required edits.
	Press to remove a controller. The controller and all regions and configurations using it will be deleted.  <b>IMPORTANT: When deleting a controller, all regions and configurations using it will be deleted.</b>
	The <b>Controller Settings</b> button allows the user to view valve settings for hydraulic flow and pulses per revolution. For more information, see “Controller Settings for KINZE® Hydraulic Drive” on page 5-52 and “Controller Settings - Auxiliary Tab” on page 5-53.

## CONTROLLER SETTINGS FOR KINZE® HYDRAULIC DRIVE

### Channel Tabs

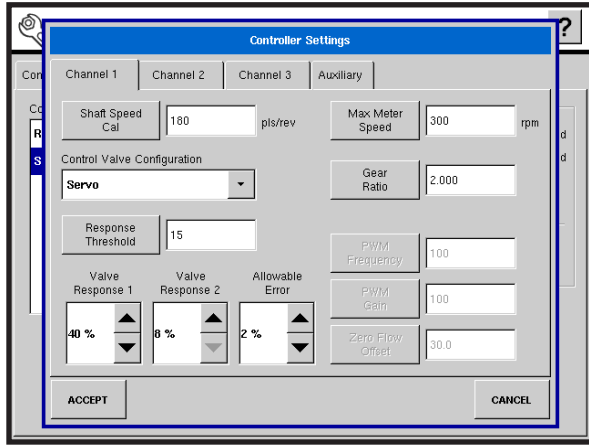

Hydraulic Controller Settings - EdgeVac®

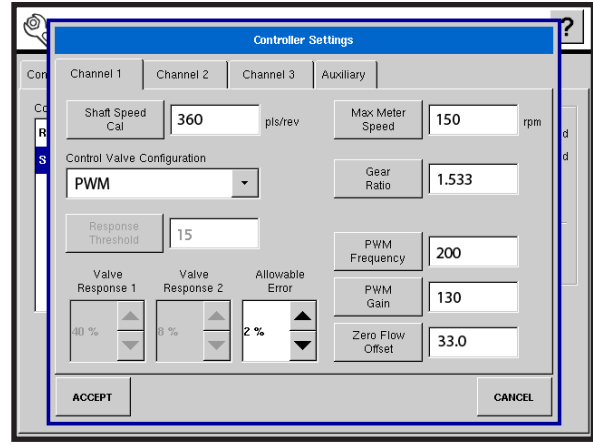

Hydraulic Controller Settings - Mechanical

Setting	Description	EdgeVac Value	Mechanical Value
<b>Shaft Speed Cal</b>	Calibration number representing the pulses that equal one revolution of the hydraulic motor (pls/rev).	360	360
<b>Control Valve Configuration</b>	Setting determines the type of control valve being used for the hydraulic motor. Choices include Servo or RPM.	PWM	PWM
<b>Max. Meter Speed</b>	Setting determines the maximum RPM of the seed meter.	150	150
<b>Gear Ratio</b>	Ratio of the revolutions of the hydraulic drive as compared to the revolutions of the seed meter.	2.947	1.533
<b>PWM Frequency</b>	The frequency that the PWM control valve is pulsed at. Settings can be found from the manufacturer of the valve. Typical settings range from 180–220 Hz.	200	200
<b>PWM Gain</b>	Determines how aggressively the control valve responds when making rate change adjustments. The higher the value the more aggressive the system response is.	60	130
<b>Zero Flow Offset</b>	Represents the maximum duty cycle that is sent to the control valve without producing any hydraulic flow from the PWM valve. Using too high of a Zero Flow Offset value can cause the product control system to not properly control low rates. See the PWM valve manufacturer's information for recommended settings.	45	33
<b>Allowable Error</b>	Determines the percent of error that is allowed prior to the product control system making any flow rate changes.	2%	2%
<b>Response Threshold</b>	Determines the system responsiveness to rate change.	----	----
<b>Valve Response 1</b>	Determines the speed of the servo valve when product control error exceeds the Response Threshold setting.	----	----
<b>Valve Response 2</b>	Determines the speed of the servo valve when product control error is less than the Response Threshold setting.	----	----

## Controller Settings - Auxiliary Tab

The Auxiliary Tab of the Controller Settings window adjusts the responsivity of the motion detection sensor that turns the KINZE Hydraulic Drive on and minimizes skips.

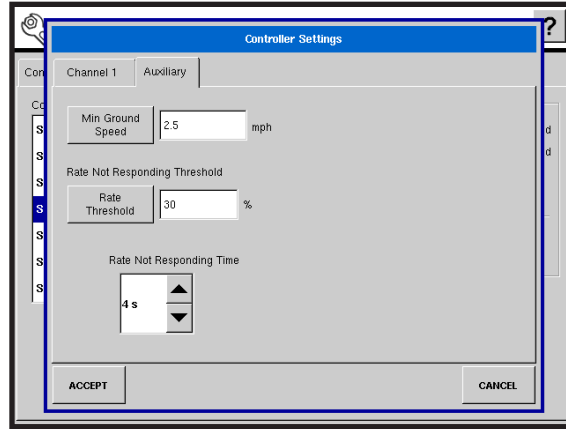

Hydraulic Controller Settings Window - Auxiliary

Setting	Description
<b>Min. Ground Speed</b>	The Minimum Ground Speed performs two functions: It determines the speed at which the motion detection sensor disengages; and also determines the minimum speed meter RPM when the motion detection sensor is active.
<b>Rate Threshold</b>	The percentage of seed rate error that triggers the alarms.
<b>Rate Not Responding Time</b>	The amount of time that the error occurs before the alarm sounds.

## ADDING A NEW CONTROLLER

Supported controllers for a planting or seeding operation include the Rawson® AccuPlant™, AccuRate™, and the Flexi-Coil® FlexControl™. To add one of these controllers press the **Add** button.

### STEP 1 Select Controller Type

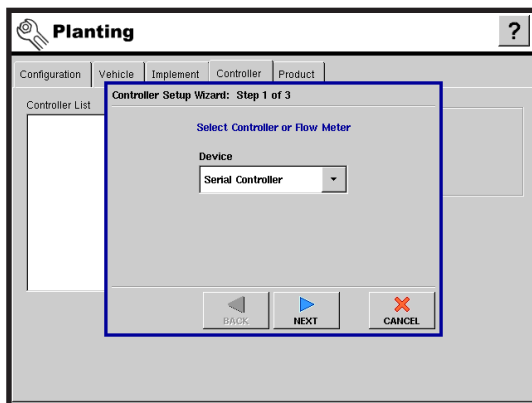

The Controller Setup Wizard appears.

Choose a serial controller or a planting flow meter from the drop down box.

Press **NEXT** to continue.

## ADDING A NEW CONTROLLER (Continued)

### STEP 2 Select Controller Make/Model Or Flow Meter Pulses

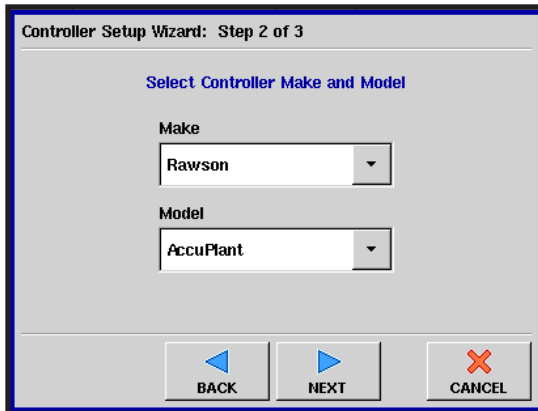

If you chose a serial controller in step one, choose the make and model of your controller from the drop down boxes. If you chose planting flowmeter, enter the flow meter calibration number in seeds per pulse using the number pad button.

Press **NEXT** to continue.

**NOTE:** The following equation determines the number of seeds per pulse for a planting flowmeter:

$$\begin{aligned} & \text{(Number Of Seeds Dispensed Per} \\ & \text{Revolution Of Sprocket Per Row)} \\ & \\ & \text{(# Of Sprocket Teeth)} \\ & \quad \times \\ & \text{(Total Number Of Rows)} \\ & \quad = \\ & \text{(Seeds Per Pulse)} \end{aligned}$$

### STEP 3 Edit Name



Edit the name of the controller.



Press **Finish** to complete the controller setup process.

## PRODUCT TAB SETTINGS

The Product tab allows you to add new products or edit existing products for planting and seeding.

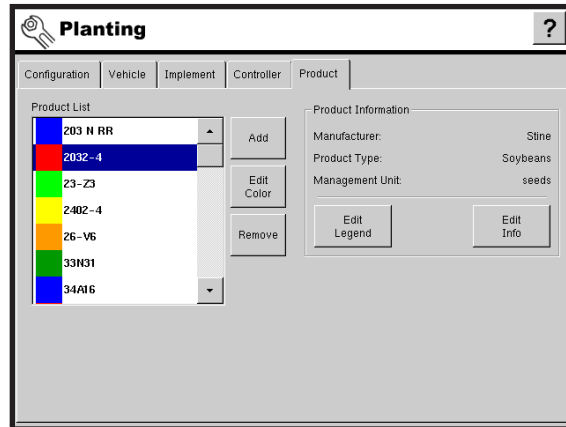
To see a Planting Configuration Menu that includes Product tab settings, see *“SeedCommand™ Menu Tree” on page 7-3.*

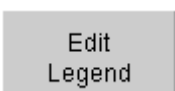
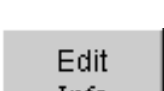

Button	Description
	The <b>Add</b> button allows you to add a new product. A wizard will walk you through setting up the product. For detailed information see <i>“Adding A New Product” on page 5-56.</i>
	The <b>Edit Color</b> button allows you to edit the color associated with a product. To edit, highlight the name of a product in the list and then press this button. If a new color is selected only data logged after the color change will use the new color.
	The <b>Remove</b> button allows you to remove a product. The product and any regions using it will be deleted.  <b>IMPORTANT: When deleting a product all regions using it will be deleted.</b>
	The <b>Edit Legend</b> button launches a wizard that allows you to change the legend associated with the selected product. For further information, see <i>“Edit Legend and Edit Info” on page 5-59.</i>
	The <b>Edit Info</b> button allows you to specify the manufacturer of a variety in the Product Information. For further information, see <i>“Edit Info” on page 5-59.</i>

## ADDING A NEW PRODUCT

To add a new product press the **Add** button located on the Product Tab. The Product Options window appears, as shown below.

### Select Product Option

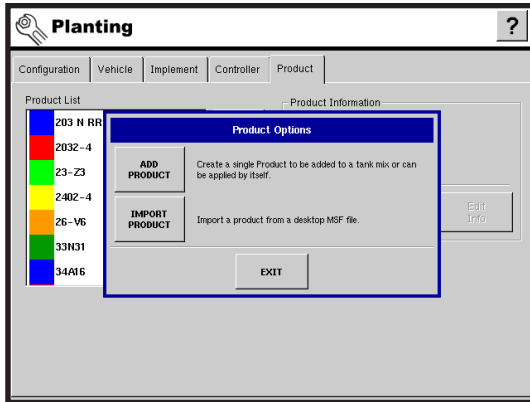

Press the **Add Product** button located on the Product Options window. The Variety Setup Wizard appears, as shown in the following step.

The **Import Product** button allows you to import a product from a desktop .msf file. For more information on importing products from desktop .MSF files, see *"Import Product" on page 5-57*.

### STEP 1 Select Crop Type

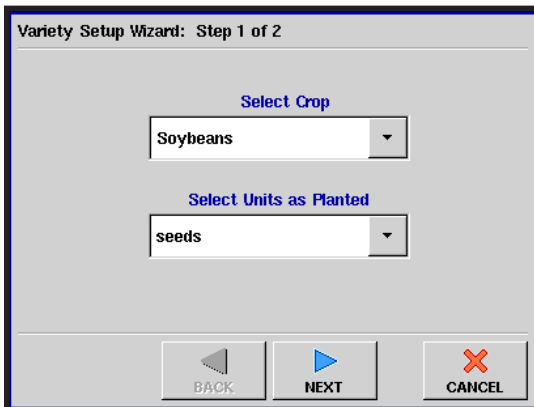

The Variety Setup Wizard appears, as shown at left. Select a Crop type and the Units As Planted from the drop down menus.

Press **Next**.

### STEP 2 Enter Variety Information

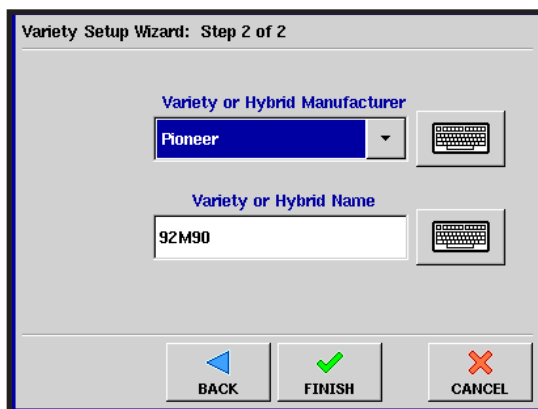

Enter the manufacturer name and the variety or hybrid. Only the variety or hybrid name is required.

Press **Finish**.

## IMPORT PRODUCT

To import a product from a desktop .MSF file, press the **Add** button located on the Planting tab. The Product Options window appears, as shown below.

### Select Product Option

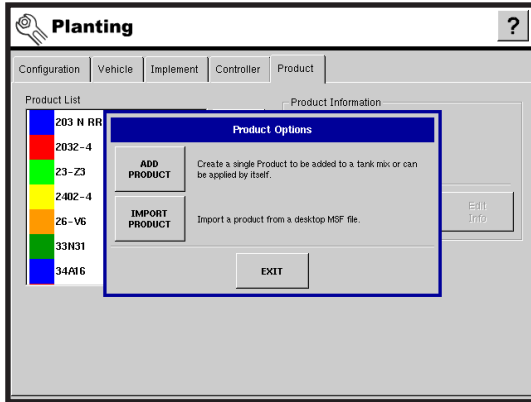

Press the **Import Product** button located on the Product Option window.

### STEP 1 Select Product And Type



The Product Import Wizard appears, as shown at left. Select the Product and Type from the drop down menus.

### STEP 2 Select Units

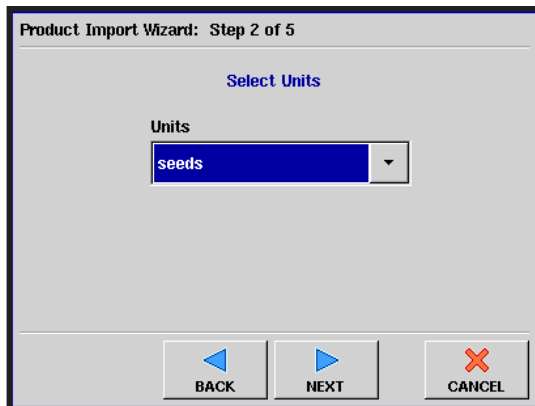

Select the units of the product.

## IMPORT PRODUCT (Continued)

### STEP 3 Enter Manufacturer And Common Name

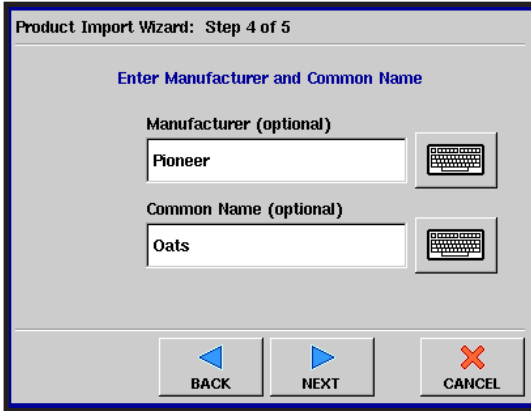

The screenshot shows a window titled "Product Import Wizard: Step 4 of 5". The main heading is "Enter Manufacturer and Common Name". There are two input fields: "Manufacturer (optional)" containing the text "Pioneer" and "Common Name (optional)" containing the text "Oats". Each input field has a keypad icon to its right. At the bottom, there are three buttons: "BACK" with a left arrow, "NEXT" with a right arrow, and "CANCEL" with a red X.

Enter the Manufacturer and Common Name, if desired.

### STEP 4 Enter Product Name



The screenshot shows a window titled "Product Import Wizard: Step 5 of 5". The main heading is "Enter Product Name". There is one input field containing the text "Oats 2113" with a keypad icon to its right. At the bottom, there are three buttons: "BACK" with a left arrow, "FINISH" with a green checkmark, and "CANCEL" with a red X.

Use the keypad to enter or change the product name. Press **Finish** when complete.

## EDIT LEGEND AND EDIT INFO

### Edit Legend

To access the Legend Settings box, press the **Edit Legend** button on the Product Tab. Editing this setting will change the default legend that is displayed on the Run screen for a Planting or Seeding operation. The legend can be further edited at any time from the Run screen. For more information see *“Map Legend” on page 6-11.*

### Legend Settings Window

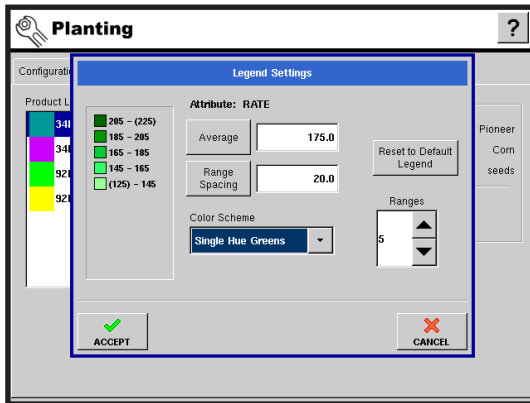

The Legend Settings window allows you to change the default legend for the rate applied. The legend settings that are made here will affect all regions. The **Average** button will change the average rate for the legend. The **Range Spacing** button changes the difference between the rates in one color range. The ranges arrows change how many ranges are displayed in the legend. The color scheme can be modified by using the drop down list. To reset the legend to the default press the reset to default legend button.

### Edit Info

To access the Product Settings window, press the **Edit Info** button on the Product tab.

### Product Settings Window

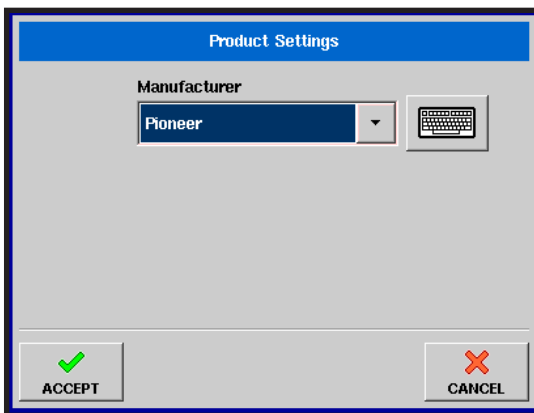

The Product Settings window allows you to specify or change the manufacturer of a specific variety. Select a new manufacturer in the drop down menu, or use the keypad to enter in a new manufacturer.

The manufacturer's information will be displayed in the Production Information area of the Product Tab. It can also be used in SMS™ Software.

## SEEDCOMMAND™ KINZE® PLANTER MONITOR CONFIGURATION

The following procedure describes the complete process of configuring a SeedCommand KINZE Planter Monitor. To begin, press the **Setup** button and go to the Configuration tab. Here you can select the equipment configuration type.

**NOTE:** This procedure assumes that you have already set up a Vehicle configuration. If you have not done so, see *“Adding A New Vehicle”* on page 5-28.

### STEP 1 Select Vehicle

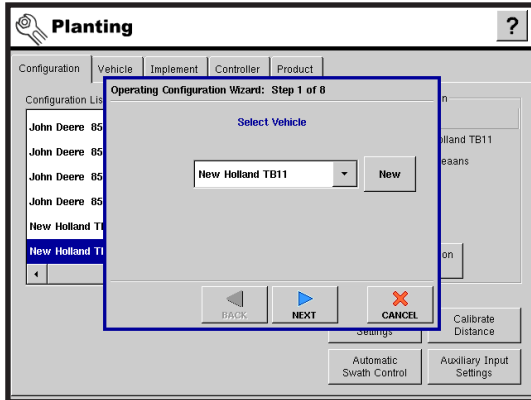

At the Configuration Tab, press the **Add** button and the Operating Configuration Wizard appears. Select an existing Vehicle from the drop down menu, or press the **Add** button and create a new vehicle with the Vehicle Setup Wizard.

Press **Next** to continue.

### STEP 2 Select Implement



Using the drop down box, select the implement you would like to use in this configuration. If there are no implements in the list, press the **New** button.

**NOTE:** For help with the Adding a New Implement Wizard, see *“Adding A New Implement”* on page 5-32.

Press **Next** to continue.

## SEEDCOMMAND™ KINZE® POPULATION MONITOR CONFIGURATION (Continued)

### STEP 3 Select Planter/Seeder Type And Attachment Method

From the top drop-down menu, select the **Planter** setting. Then use the bottom drop down menu to select an appropriate attachment Method.

Press **Next** to continue.

### STEP 4 Select Implement Options

Select the following options, depending upon your machine's configuration:

- **KINZE Planter Monitor Module** - Check this box to enable the KINZE Vision planter monitor functions.
- **Interplant Rows Enabled** – Check this box to enable to log data from the planter's Interplant units. (For Interplant planters, you will need to create separate implement configurations for Interplant and non-Interplant operations).
- **Planter Section Clutch Control** – Check this box to enable the clutch control and planter clutches.

Press **Next** to continue.

### STEP 5 Enter The Number Of Rows And Spacing

Use the up and down arrow keys to enter the number of rows and spacing.

**NOTE:** These numbers will vary depending upon the crop that you are planting. For example, corn may require a 16 row, 30-inch spacing configuration; while soybeans could possibly require a 31 row, 15-inch spacing configuration.

When finished, press **Next**.

## SEEDCOMMAND™ KINZE® POPULATION MONITOR CONFIGURATION (Continued)

### STEP 6 Enter The Number Of Implement Sections

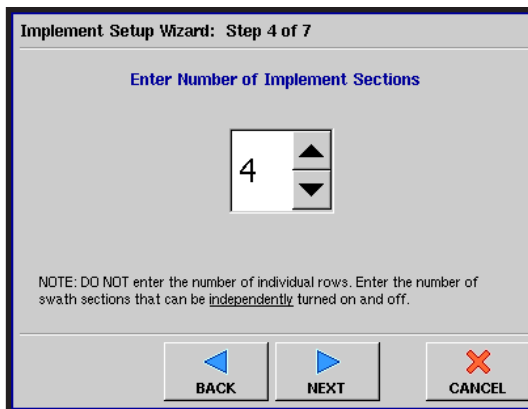

Use the up and down arrow keys to enter the number of implement sections, and press **Next**.

**NOTE:** Do not enter the number of individual rows. Enter the number of swath sections that can be independently turned on and off.

### STEP 7 Enter Section Widths From Left To Right

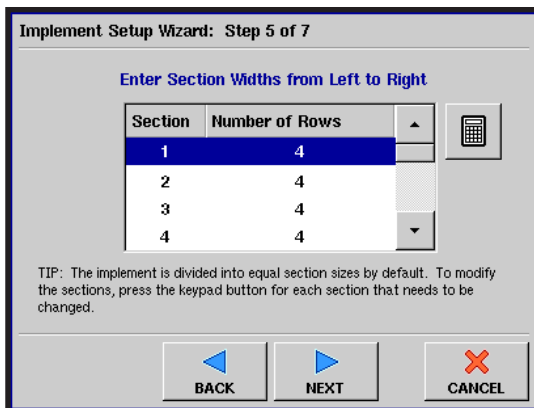

The Enter Section Widths from Left to Right window appears. This window shows the number of sections and number of rows in your configuration. From here you can:

- Press **Next**, or
- Highlight the section number, and use the numeric keypad to change the section row numbers; then press **Next**.

**NOTE:** The implement is divided up into equal section sizes by default. To modify the sections, press the keypad button for each section that needs to be changed.

### STEP 8 Enter Distance From Hitch To Application Point

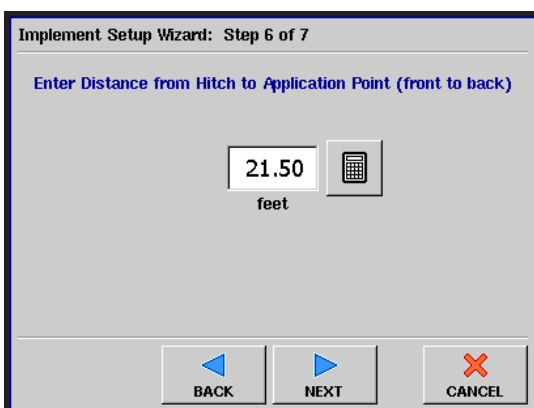

Use the numeric keypad to enter the distance from the implement hitch to the application point (from front to back). When finished, press **Next**.

**NOTE:** When using Interplant, the distance can be to the application point of the push-units, the pull-units, or to a point in between as determined by the operator.

## SEEDCOMMAND™ KINZE® POPULATION MONITOR CONFIGURATION (Continued)

### STEP 9 Enter Implement Name

Implement Setup Wizard: Step 7 of 7

Enter Implement Name

BACK FINISH CANCEL

Use the keyboard button to enter an Implement Name, then press **Finish**.

### STEP 10a Select Operation Type

Operating Configuration Wizard: Step 3 of 8

Select Operation Type

Area Logging (Site Verification)

BACK NEXT CANCEL

The Operating Configuration Wizard reappears, as shown at left. You must select an operation type. Select either Area Logging (Site Verification) or Rate Logging/Control.

- For configurations that include a Hydraulic Seed Rate or Rawson® Control option, you must choose Rate Logging/Control. Press **Next** to continue and proceed to “STEP 10b” on page 5-63.
- For configurations that do not include the Hydraulic Drive option, you must choose Area Logging (Site Verification). Press **Next** to continue and skip ahead to “STEP 10c” on page 5-64.

### STEP 10b Select Controller (For Rate Logging/Control)

Operating Configuration Wizard: Auxiliary Step

Select Controller

Planting Meter New

BACK NEXT CANCEL

Select an existing Controller from the drop down menu, or press the **New** button and use the Controller Setup Wizard to create a controller.

Press **Next** to continue and skip ahead to “STEP 10c” on page 5-64.

## SEEDCOMMAND™ KINZE® POPULATION MONITOR CONFIGURATION (Continued)

### STEP 10c Select Planting Method (For Area Logging/Site Verification)

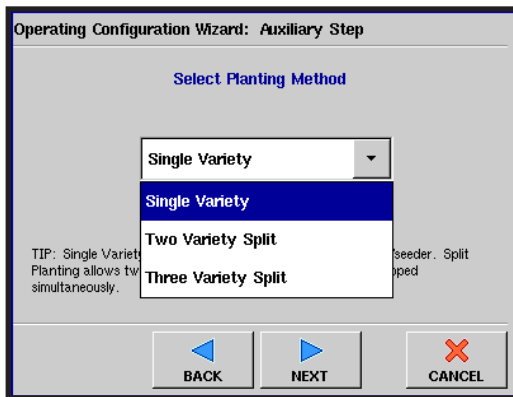

Select either Single Planting or Split Planting (Two Variety Split or Three Variety Split).

Press **Next** to continue and proceed to “STEP 10d” on page 5-64.

### STEP 10d Assign Sections To Splits On Planter (For Area Logging/Site Verification)

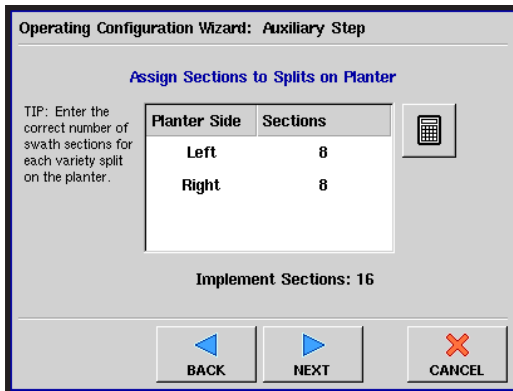

Press the touchpad and choose the Planter Side where you wish to assign sections. Then press the numeric keypad to enter the number of sections.

Press **Next** to continue.

### STEP 11 Add Additional Application Equipment (Optional)

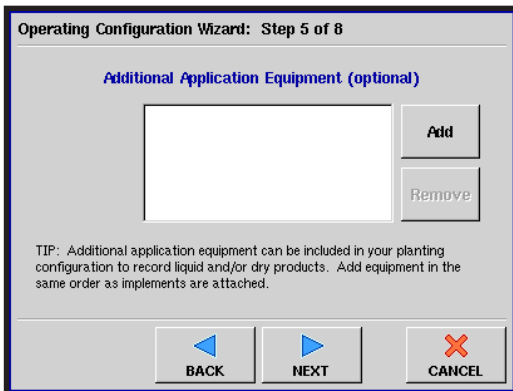

If you plan to use additional application equipment for a secondary operation (such as a liquid starter control), press the **Add** button and use the Equipment Configuration Wizard to add equipment.

Press **Next** to continue.

## SEEDCOMMAND™ KINZE® POPULATION MONITOR CONFIGURATION (Continued)

### STEP 12 Select Ground Speed Source

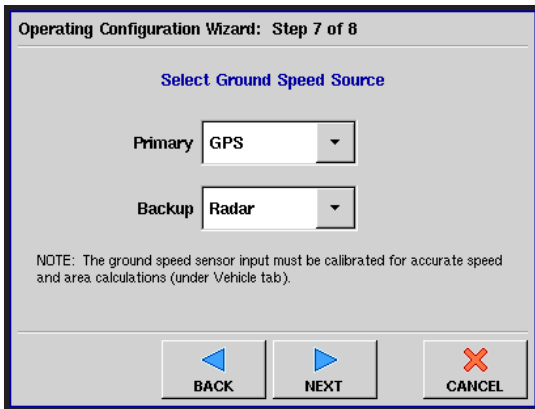

Select a Primary and Backup Ground Speed Source, (such as GPS, Wheels, Track or Radar).

Press **Next** to continue.

### STEP 13 Enter Suggested Name For Configuration

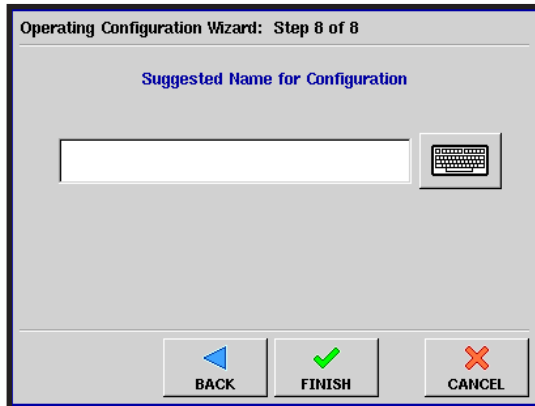

Use the keyboard button to enter a name for the configuration.

Press **Finish** when complete.

## SEEDCOMMAND™ CLUTCH CONTROL CONFIGURATION

The following procedure describes how to configure a Clutch Control Module, which is a function of SeedCommand. This procedure includes several sub-tasks, including configuring an implement, configuring the clutch modules, and creating a planting configuration.

**NOTE:** This procedure assumes that you have already configured a vehicle. If you have not configured a vehicle, see “Planting Setup Tabs” on page 5-1. For clutch control installation information, see “Adding A New Controller” on page 5-53.

### STEP 1 Set Implement Attachment Wizard

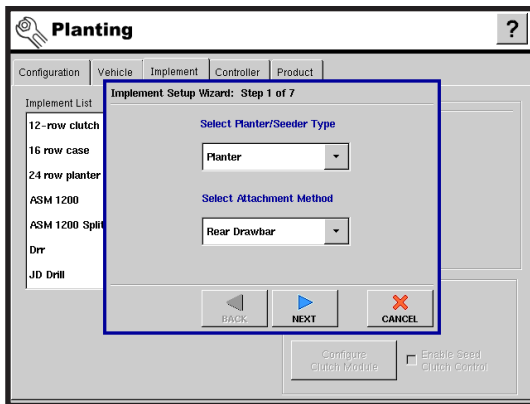

On the Implement Tab, press the **Add** button. The Implement Setup Wizard appears, as shown at left.

Use the top drop down menu to select the planter or seeder type. Then use the bottom drop down menu to select the Implement Attachment Method.

When finished, press **Next**.

### STEP 2 Select Planter/Seeder Type

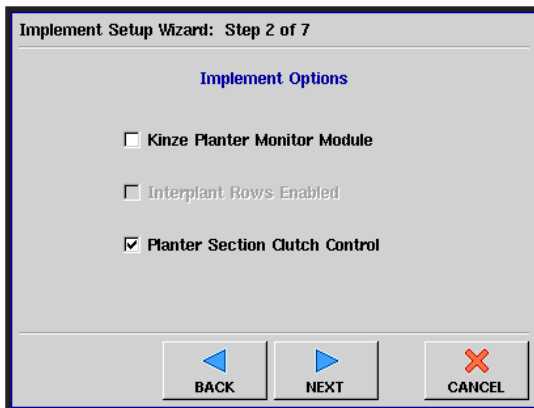

Select the following options, depending upon your desired configuration:

- **KINZE Planter Monitor Module** - Check this box to enable the KINZE Vision planter monitor functions.
- **Interplant Rows Enabled** – Check this box to enable to log data from a KINZE planter’s Interplant® units.
- **Planter Section Clutch Control** – Check this box to enable the SeedCommand planter clutches.

**NOTE:** The **Planter Section Clutch Control** check box must be checked in order to use **Clutch Control** functionality.

Press **Next** to continue.

## SEEDCOMMAND™ CLUTCH CONTROL CONFIGURATION (Continued)

### STEP 3 Enter Number Of Rows And Spacing

Use the **UP** and **DOWN** arrows to enter the number of rows and spacing, and press **Next**.

### STEP 4 Enter Number Of Implement Section(s)

Use the **UP** and **DOWN** arrows to enter the number of clutch sections, and press **Next**.

**NOTE:** Do not enter the number of individual rows. Enter the number of swath sections that can be independently turned on and off.

### STEP 5 Enter Section Widths From Left To Right

Section	Number of Rows
1	4
2	4
3	4
4	4

The Enter Section Widths from Left to Right window appears. This window shows the number of sections and number of rows in your configuration. From here you can:

- Press **Next**, or
- Highlight the section number, and use the numeric keypad to change the section row numbers; then press **Next**.

**NOTE:** The implement is divided up into equal section sizes by default. To modify the sections, press the keypad button for each section that needs to be changed.

## SEEDCOMMAND™ CLUTCH CONTROL CONFIGURATION (Continued)

### STEP 6 Enter Distance From Hitch To Application Point

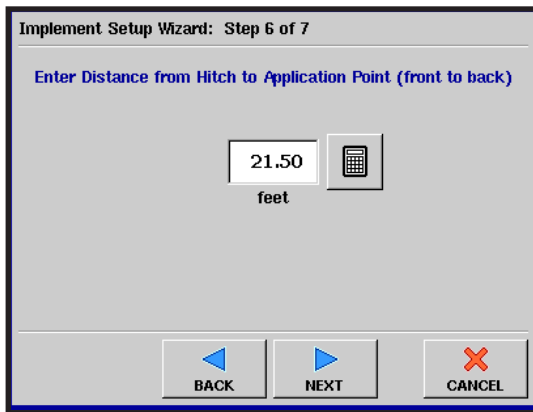

Use the numeric keypad to enter the distance from the implement hitch to the application point (from front to back).

When finished, press **Next**.

### STEP 7 Enter Implement Name

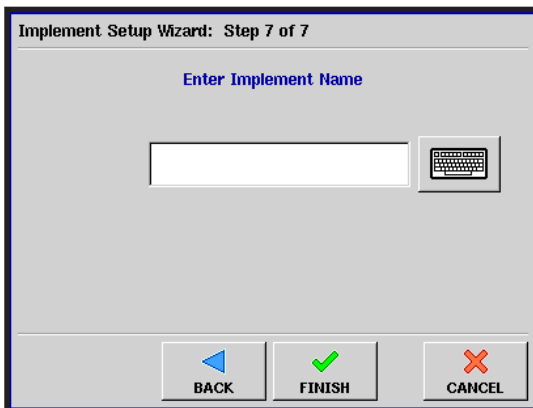

Use the numeric keypad to enter a name for the implement, and press **Finish**.

### STEP 8 Enable Seed Clutch Control

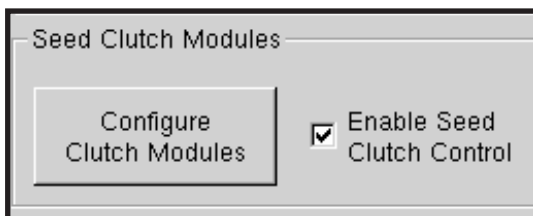

On the Implement Tab, first highlight the desired implement from the Implement List, then check the Enable Seed Clutch Control check box. Next, press the **Configure Clutch Modules** button.

**NOTE:** You must have the **Enable Clutch Control Module** check box selected in order to have the **Configure Clutch Control** button enabled.

## SEEDCOMMAND™ CLUTCH CONTROL CONFIGURATION (Continued)

### STEP 9 Enter Number Of Clutch Sections

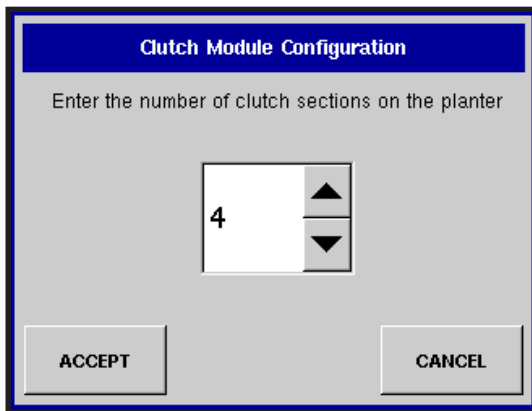

Once you have pressed the **Configure Clutch Modules** button, the Clutch Module Configuration box appears, as shown at left. Enter the same number of clutch sections that you specified in “STEP 4” on page 5-67. Then press **Accept**.

**NOTE:** If you enter in a different number of clutch sections other than that specified in the earlier implement configuration, the clutch module configuration will fail. Instead, you will see a message stating: *“The number of detected module outputs does not equal the number of planter sections.”*

You will also see this same message if you have not connected the clutches to the module. Thus, check these connections also.

### STEP 10 Configuration Complete

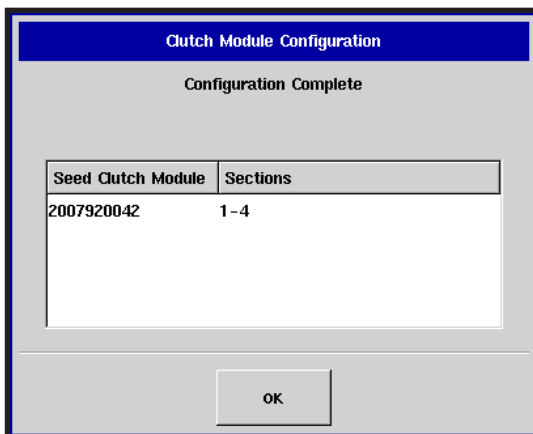

A message window appears, stating “*Configuration Complete*”. Press **OK**.

### STEP 11 Create An Operating Configuration

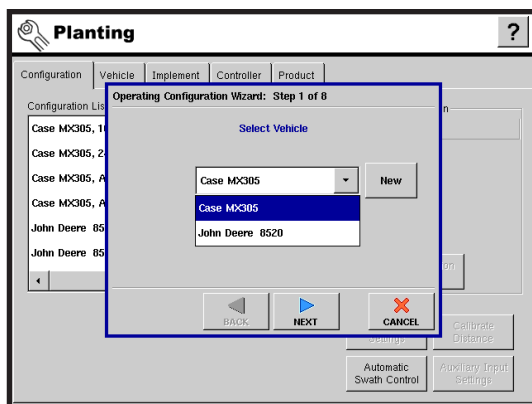

Now that you have completed the Clutch Control Configuration, you must now create an operating configuration.

Go to the Configuration Tab, and press the **Add** button. The Operating Configuration Wizard appears, as shown at left.

Select a vehicle, and press **Next**.

## SEEDCOMMAND™ CLUTCH CONTROL CONFIGURATION (Continued)

### STEP 12 Select Implement



Use the drop down menu to select an implement, and press **Next**.

### STEP 13 Select Area Logging (Site Verification)

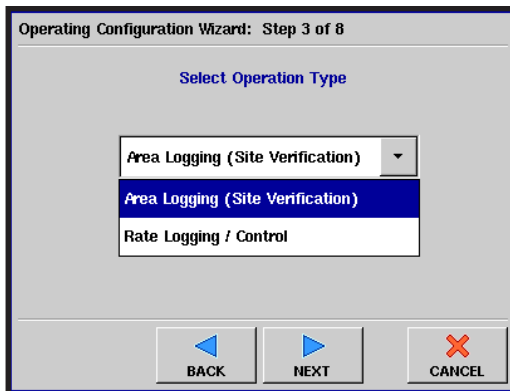

The Select Operation Type window appears, as shown at left. The window gives you the choice of Rate Logging/Control or Area Logging (Site Verification).

Choose Area Logging (Site Verification) and press **Next**.

### STEP 14 Select Planting Method

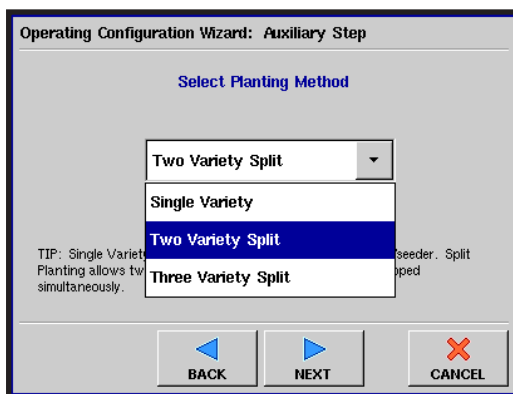

The Select Planting Method window appears. Choose either Single Variety, Two Variety Split, or Three Variety; then press **Next**.

**NOTE: Single Variety records only one variety for the entire planter/seeder. Split Planting allows two or three varieties to be recorded and mapped simultaneously.**

However, the Split Planter Configuration cannot be used for Single Variety planting. If you are planting a single variety, you must create a Single Variety configuration.

## SEEDCOMMAND™ CLUTCH CONTROL CONFIGURATION (Continued)

### AUXILIARY STEP Assign Sections To Splits On Planter (If Is Split Planter)

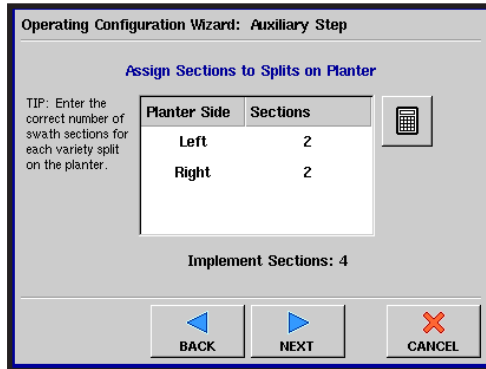

If you have chosen a Split Planter, then a window appears where you may assign sections to splits on the planter. Use the numeric keypad to enter in a different number of sections.

**NOTE:** Enter the correct number of swath sections for each variety split on the planter.

### STEP 15 Add Additional Application Equipment (Optional)

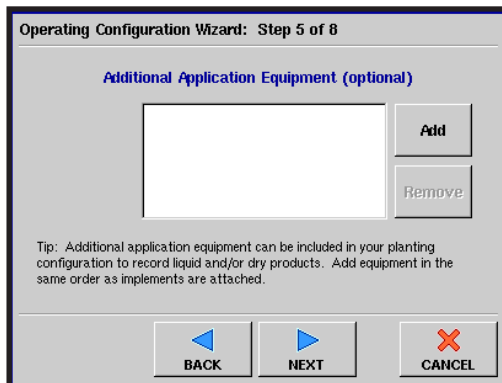

The Add Additional Application Equipment window appears. From here, you may add additional equipment or controllers to your planting configuration so that you may record liquid or dry products. For example, if you are using SreedCommand to spray a liquid application, or if you are using a serial controller, you should add this equipment to your configuration at this window.

- Add equipment by pressing the Add button and following the Equipment Configuration Wizard, (of which the first step is shown below right); or
- Press **Next** to continue.

**NOTE:** If you choose to add additional equipment, add them in the same order as the implements are attached.

## SEEDCOMMAND™ CLUTCH CONTROL CONFIGURATION (Continued)

### STEP 16 Select Implement Switch (None)

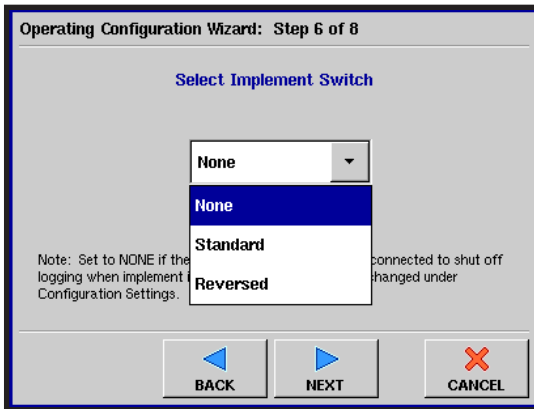

The Select Implement Switch window appears. Choose **None** and press **Next**.

### STEP 17 Select Ground Speed Source

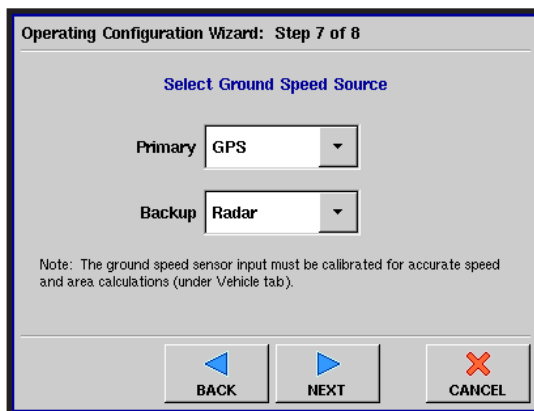

Select your ground speed source. If you will be using GPS as the primary source, you will need to select a secondary source.

Press **Next** to continue.

**NOTE: The ground speed sensor input must be calibrated for accurate speed and area calculations.**

### STEP 18 Enter Configuration Name

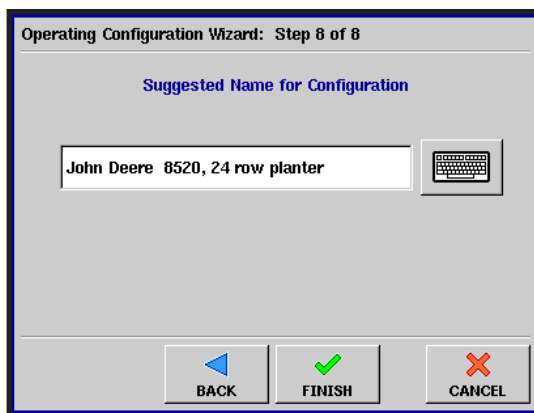

A window appears, asking you to enter a suggested configuration name. Use the keypad to enter a name, then press **Finish**.

Your Clutch Control Configuration is now complete.

## KINZE® HYDRAULIC DRIVE CONFIGURATION

To create a configuration which uses the KINZE Hydraulic Drive feature, you must create a configuration that includes a hydraulic controller. To begin, press the **Add** button. The Operating Configuration Wizard appears, as shown below.

### STEP 1 Select Vehicle

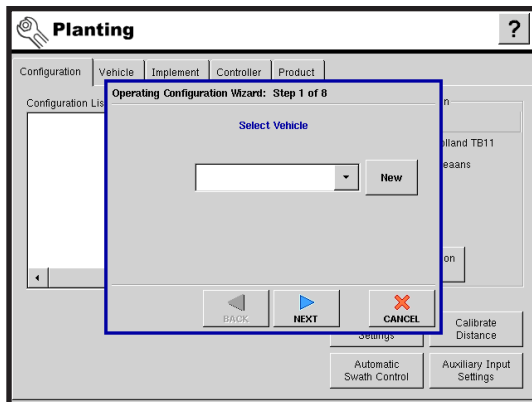

At the Configuration Tab, press the **Add** button and the Operating Configuration Wizard appears. Select an existing Vehicle from the drop down menu, or press the **Add** button and create a new vehicle with the Vehicle Setup Wizard.

Press **Next** to continue.

### STEP 2 Select Implement

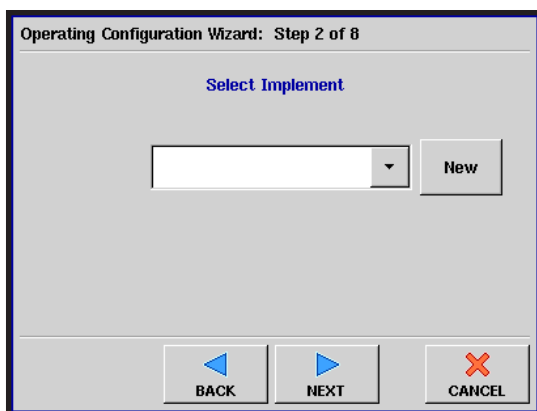

Using the drop down box, select the implement you would like to use in this configuration. If there are no implements in the list, press the **New** button.

**NOTE:** For help with the Adding a New Implement Wizard, see *“Adding A New Implement”* on page 5-32.

Press **Next** to continue.

### STEP 3 Select Operation Type



Select the Rate Logging/Control operation type.

Press **Next** to continue.

## KINZE® HYDRAULIC DRIVE CONFIGURATION (Continued)

### AUXILIARY STEP

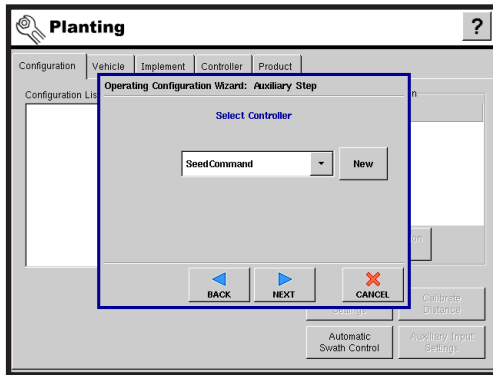

Select an existing controller from the drop-down menu, or press the **New** button and use the Controller Setup Wizard to create a controller.

### STEP 4 Select Device and Seed Command Type

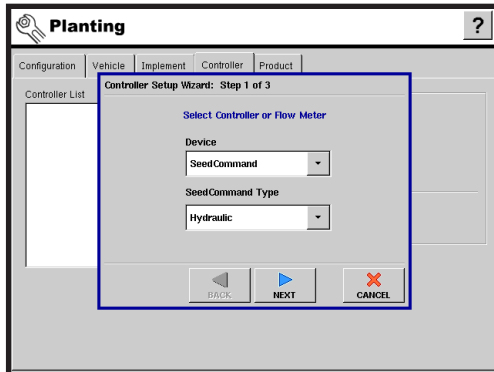

After pressing the **New** button, the Controller Setup Wizard appears, as shown at left. Use the drop down menus to select **SeedCommand** as your device. Use the bottom drop-down menu to select **Hydraulic** as the SeedCommand Type.

Press **Next** to continue.

### STEP 5 Enter number of drives

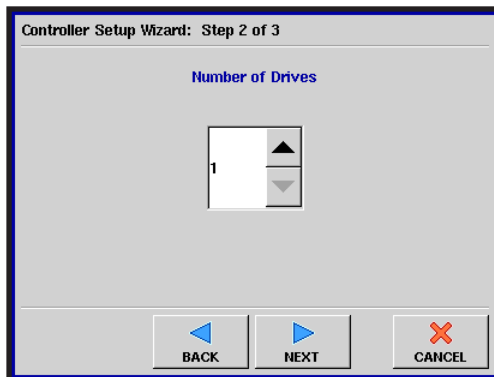

Use the up and down arrows to enter in the number of hydraulic drives on your planter.

Press **Next** to continue.

## KINZE® HYDRAULIC DRIVE CONFIGURATION (Continued)

### STEP 6 Enter Suggested Controller Name

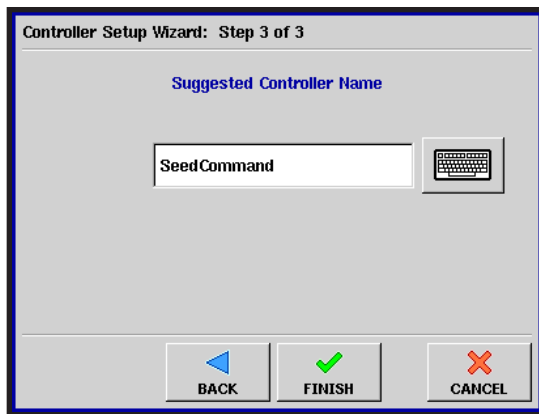

A suggested controller name appears. If necessary, use the on-screen keyboard to edit the name of the controller.

Press **Finish** when complete.

# CONFIGURATION

---





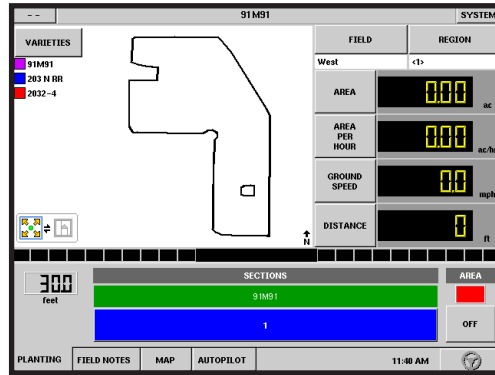

**This page intentionally left blank.**

## RUN SCREEN BUTTONS

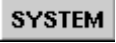

Before the Run screen can become active, you must go to the **Field** button and accept a field, configuration, product, and region. For detailed information see *“Field Button while not logging”* on page 6-5.



**Planter Run Screen**

Planting Button	Description
	<p>The <b>Field</b> button functionality changes based upon the status of the master switch. If the master is off it allows you to change grower, farm, field, and configuration. If the master status is on it allows you to view field totals. For more information, see <i>“Field Button While Logging”</i> on page 6-7; and <i>“Field Button while not logging”</i> on page 6-5.</p>
	<p>The <b>Region</b> button allows you to change and name regions of the field. For more information, see <i>“Region Button”</i> on page 6-6.</p>
	<p>The <b>System</b> button displays diagnostic information about the internal memory of the display, display information, and CAN module information. For more information, see <i>“System Diagnostic Button”</i> on page 6-21.</p>
	<p>Press the <b>DGPS</b> button to display information about the GPS. For more information, see <i>“GPS General Tab”</i> on page 4-56.</p>
	<p>The master button controls area logging. When the switch is green, area is being recorded and displayed on the map. This option will not be available when using a Serial Controller.</p>
	<p>When the master button is set to <b>OFF</b>, the area is not being recorded and the map will stop drawing. The switch will remain red until the button is pushed again to set it to auto. This option will not be available when using a Serial Controller.</p>

**RUN SCREEN BUTTONS (Continued)**

Planting Button	Description
 Master Switch - ON	The Master Switch Position Indicator, shown for SeedCommand functions, shows if the master switch is on (green) or off (red). The master switch is shown in the <b>F1</b> position on the Auxiliary Input Settings window. For more information, see <i>“Auxiliary Input Settings (Switch Mapping)”</i> on page 5-25.
 Master Switch - OFF	

**NOTE:** Run screen settings for individual configurations are discussed on the following pages:

# OPERATION

# RUN SCREEN MAIN TABS

## Seed Tab (For KINZE® Planter Monitor)

The Seed tab is a Run Screen function of the KINZE Population Monitor, a SeedCommand product. For more information, see “KINZE® Planter Monitor” on page 6-13.

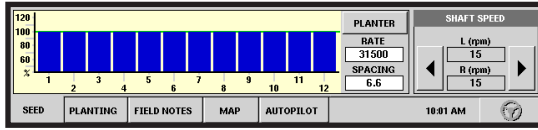

Seed Tab - For KINZE Planter Monitor

## Planting Tab (For Site Verification)

For more information on the Planting Tab, see “Planting Tab - Site Verification” on page 6-4.

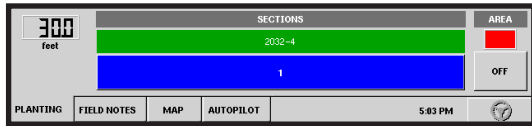

Planting Tab

## Planting Tab (For Clutch Control)

The appearance of the Planting Tab varies, depending upon whether you are using the Clutch Control, a SeedCommand product. For more information, see “SeedCommand™ Clutch Control Configuration” on page 5-66. The example below shows an implement with 12 sections.

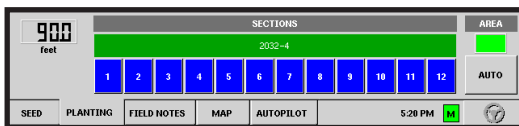

Planting Tab - for Clutch Control

## Planting Tab (For KINZE® Hydraulic Drive)

The appearance of the Planting Tab also varies if you are using the KINZE hydraulic drive feature, with one or more hydraulic drive motors. The top grey bar shows the speed of the hydraulic drive motor, in RPM. The green bar shows the variety planted. The bottom row shows the number of sections on the planter. The **Drive Control** button summons the Planter Control window, where you can enter a meter calibration number, perform a seed meter calibration, or use the Seed Meter Prime. For more information, see “KINZE® Planter Control” on page 6-16.

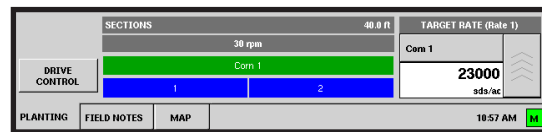

Planting Tab - for KINZE Hydraulic Drive

## Field Notes Tab

For more information on the Field Notes tab, see “Field Notes Setup Screen” on page 4-27.

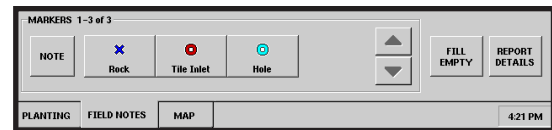

Field Notes Tab

## Map Tab

For more information on the Map Tab, see “Map Tab Basics” on page 4-64.

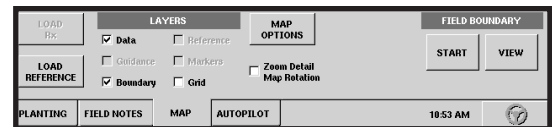

Map Tab

## Planting Tab - Site Verification

The Planting tab is where area is controlled for site verification and split planter logging. The planter sections display buttons that have section names. When the section is active and logging data it will have a blue bar above it. To turn individual sections on or off press the section button. The full swath width of the active sections is displayed in the upper left hand corner of the tab. The master switch on the right side of the tab controls area logging.

- If the master switch is set to **Off**, no area will be logged.
- When the master switch is set to **Auto**, the display will log data.
- If an implement switch is being used, it must be set to **Auto**, and the Implement Switch must be in the data logging position, the master switch will be green.

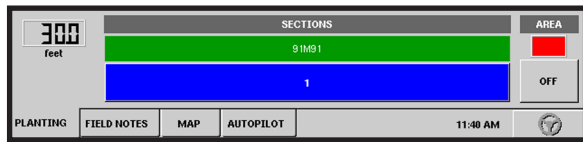

Single Product Logging

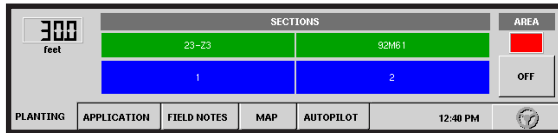

Split Planter Logging

## Planting Flow Meter (Shaft Speed Sensor)

The Planting Tab is where area is controlled for planting with a Shaft Speed Sensor. The planter sections will have buttons with section numbers on them. When the section is on and logging data, it displays a blue bar above it. If it is turned off and not logging data it will have a grey bar above it. To turn individual sections on or off, press the Section button. The full swath width of the sections that are turned on is displayed in the upper left hand corner of the tab. The master switch on the right side of the tab controls area logging. If it is set to **Off**, no area will be logged.

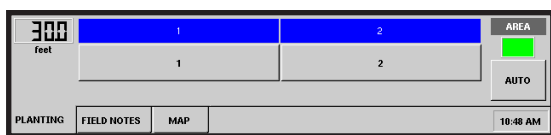

Planting Tab (With Flow Meter)

## Serial Controlled Planting

The Planting Tab is where the rate control of a serial controller takes place. When the section is active and is logging data, it will have a blue bar above it.

To load a map-based prescription file, press the **Load Rx** button. This will allow you to choose a prescription file off of the external card. Once selected the button will change to **Clear Rx**. This will allow you to clear out the selected prescription.

To manually change the Target Rate, press the arrow button in the target rate box. In the Target Rate dialog, you are allowed to set two preset rates. Press the **Preset Rate 1** or **Preset Rate 2** button and use the up and down arrow buttons to change the rate. Press **OK** when finished.

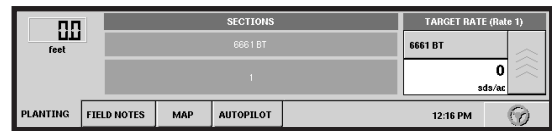

Rate-Controlled Planting Via Serial Cable

## Multiple Implement Configurations

If you are using a configuration with multiple implements, each implement is displayed on its own tab.

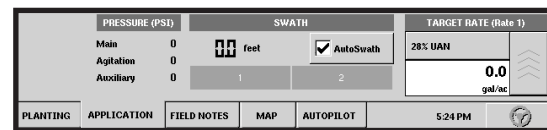
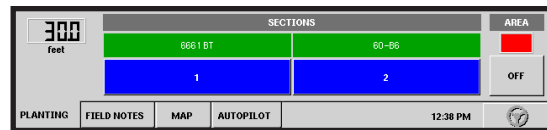

Planting Simultaneously With Starter Fertilizer

## Target Rate

Certain planting configurations use the **Target Rate** button, as shown in the right-hand side of the tab immediately shown above. These planting configurations include:

- A serial control configuration with a hydraulic drive, such as a Rawson® AccuRate™.
- A Liquid DirectCommand™ module.

The start of planting or seeding in a field is accomplished by setting up a Field Operation at the Run Screen. This process is similar regardless of the type of field operation currently taking place. To begin, press the **Field** button on the Run screen, and the Field Operation Wizard appears, as shown below.

## STEP 1 Select Grower, Farm, Field

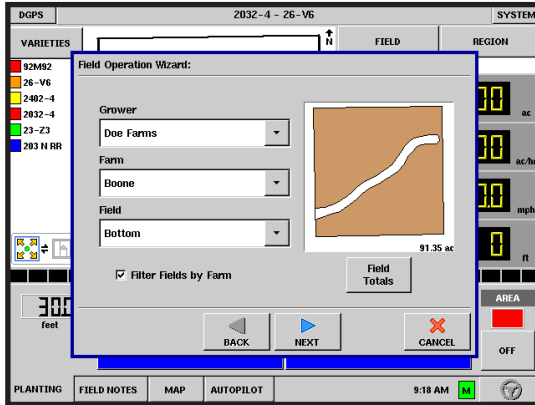

Choose the field for planting or seeding by making the proper selections from the **Grower**, **Farm**, and **Field** list boxes.

If the **Filter Fields by Farm** check is cleared, the system will display all fields in the **Field** list box regardless of what farm the fields are associated with.

Press **NEXT** to continue.

**NOTE:** You may view Field Totals by pressing the **Field Totals** button on the **Field Operation Wizard**. For more information on field totals, see *“Field Button While Logging”* on page 6-7.

## STEP 2 Choose Configuration

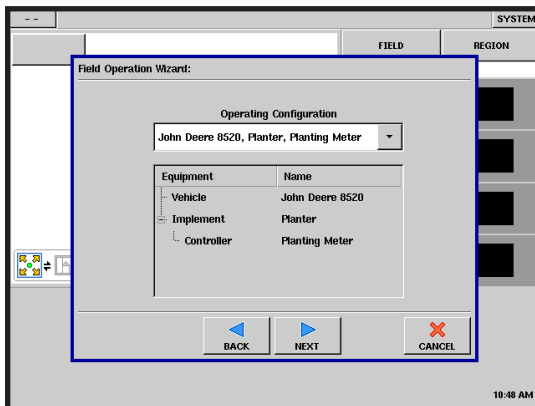

Select the Operating Configuration that relates to the equipment in use.

Press **NEXT** to continue.

## STEP 3 Select Product

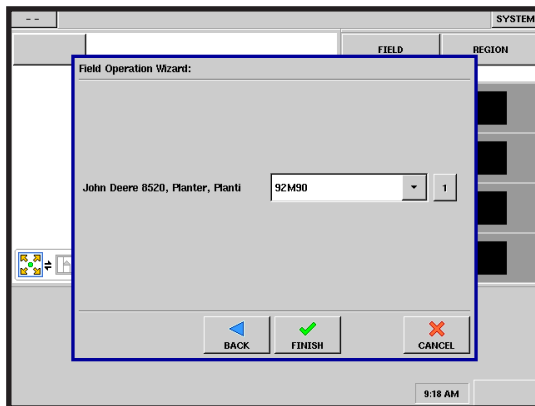

Select the correct product from the list box. In cases of multiple product application, make the appropriate selection for each channel of product control.

Press **FINISH** to complete the Field Operation portion of the setup wizard.

The Region Selection window should appear next. To learn more about the Region Selection window, see *“Region Button”* on page 6-6.

To access the Region Selection window, either complete the wizard under the **Field** button or press the **Region** button.

## Region Button

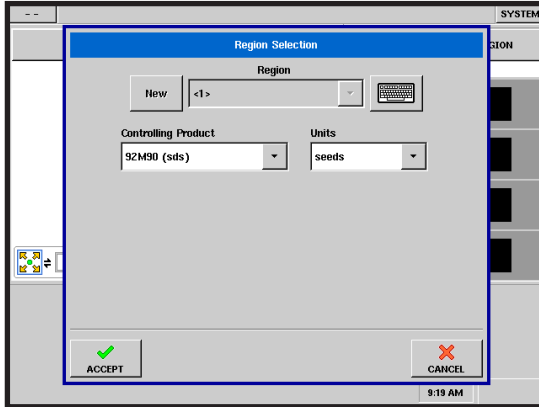

As explained in *“Run Screen Command Buttons”* on page 4-7, a region is an area within a field. A field is a collection of one or more regions.

Use the on-screen keyboard to change the region name from the system default if desired.

The system will control application based upon the product and units as defined in product setup.

## Field Button Shown While Run Screen Is Logging Data

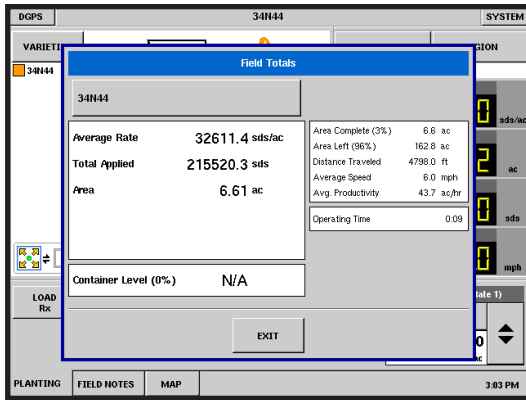

If the **Field** button is pressed while logging data, the Field Totals window will show your field totals.

# OPERATION

# SITE VERIFICATION DISPLAY ITEMS

The display items selection dialog box can be accessed by pressing on any one of the four display items that are active on the Run screen.

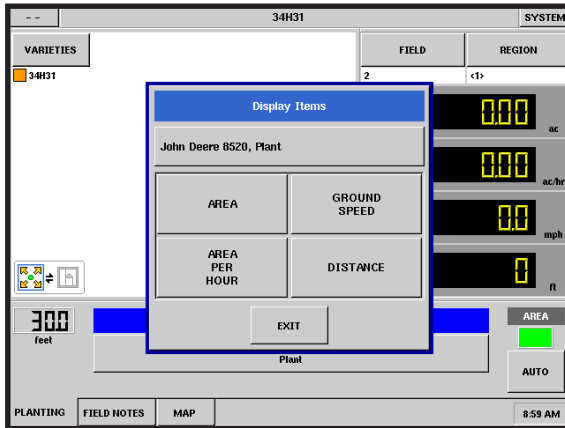

Once the Display Items window is visible press on the display item you would like to display. It will then be available on the Run screen.

Button	Description
<div style="border: 1px solid black; padding: 10px; text-align: center; width: 100px; margin: 0 auto;">AREA</div>	Displays the area that has been planted or seeded in the region.
<div style="border: 1px solid black; padding: 10px; text-align: center; width: 100px; margin: 0 auto;">AREA PER HOUR</div>	Shows the instantaneous productivity.
<div style="border: 1px solid black; padding: 10px; text-align: center; width: 100px; margin: 0 auto;">GROUND SPEED</div>	Shows the instantaneous ground speed.
<div style="border: 1px solid black; padding: 10px; text-align: center; width: 100px; margin: 0 auto;">DISTANCE</div>	Shows the total distance driven in the region.

# OPERATION RATE CONTROL/LOGGING DISPLAY ITEMS

The Display Items selection dialog box can be accessed by pressing on any one of the four display items that are active on the Run screen.

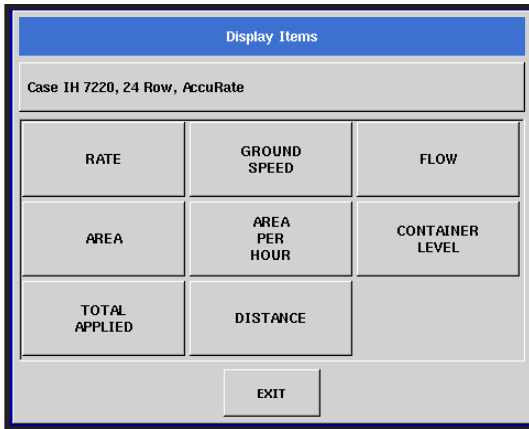

Once the Display Items window is visible, press the display item you would like to appear on the Run screen.

Button	Description
<b>RATE</b>	Displays the theoretical rate per acre being applied with hydraulic drive.
<b>AREA</b>	Displays the area that has been planted or seeded in the region.
<b>TOTAL APPLIED</b>	Shows the total amount of seed applied for the region.
<b>GROUND SPEED</b>	Shows the instantaneous ground speed.
<b>AREA PER HOUR</b>	Shows the instantaneous productivity.
<b>DISTANCE</b>	Shows the total distance driven in the region.
<b>FLOW</b>	Shows the instantaneous flow rate of seed per minute.
<b>CONTAINER LEVEL</b>	This is not currently being used in a Planting or Seeding operation.

There are four different types of viewable maps in planting depending on the type of configuration being used. A site verification configuration will only have coverage and varieties available, a rate control/logging configuration will have all four. The maps are accessed by pressing the button in the legend that is either labeled **COVERAGE**, **VARIETIES**, **RATE**, or **Rx**.

## Coverage Map

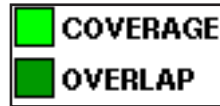

The coverage map shows the area of the field that has been planted or seeded. Overlaps are also indicated here. This legend is not editable.

## Rate Map

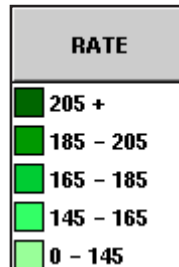

The rate map displays the actual rate being applied if a rate control/logging configuration is being used. This legend is editable.

## Varieties Map

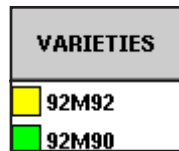

The varieties map shows the areas of the field where the varieties are planted. This legend is not editable.

## Rx Map

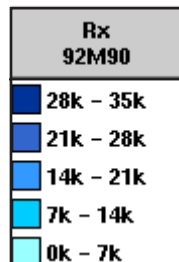

The Rx map displays the prescription rate from the target file. This legend is not editable.

The rate legend is the only planting legend that can be edited. To edit this legend, press on the range portion of the Run screen legend. (the boxes underneath the **Rate** button).

The average, spacing, colors, and ranges can be edited for this map. Use the drop down boxes and arrows to adjust these values.

If the automatic legend option is selected the average will automatically set itself to the field average and update as the field average changes.

If you choose to set the current legend as the default legend for all regions of the same product, select the Save As Product legend option. This will also reset the legend settings discussed in *"Product Tab Settings"* on page 5-55. To reset to the default values go to **Setup, Planting, Product** and press the **Edit Legend** button.

If you wish to reset this legend to the values saved under the Product tab, press the **Reset to Product Legend** button.

## Rate Legend Settings

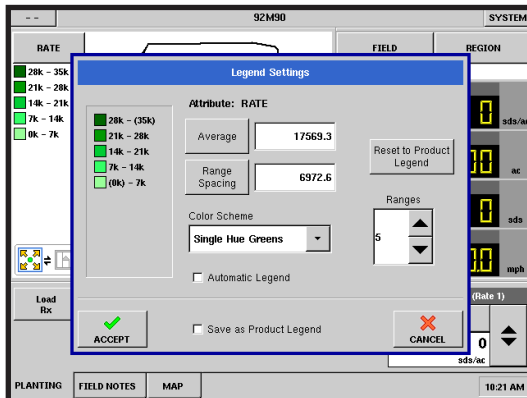

To view the Rate Legend Settings window, press the range portion of the legend (in this instance, the green boxes underneath the Run screen's rate button).

## CLUTCH CONTROL - RUN SCREEN OPERATION

To create a Clutch Control configuration, see “SeedCommand™ Clutch Control Configuration” on page 5-66.

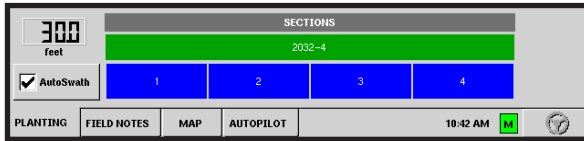

Select the AutoSwath™ checkbox to enable automatic section control.

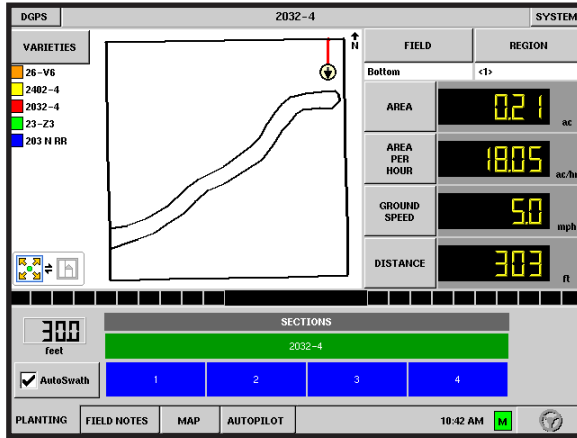

The AutoSwath™ feature for Clutch Control configurations will automatically turn individual planting unit sections on and off based upon the following mapped features in a field operation.

- Entering and exiting outer field boundaries
- Entering and exiting internal field boundaries
- Entering and exiting mapped product recommendation areas
- Entering and exiting previously applied areas within a field

At left is an example of AutoSwath™ control used with a Clutch Control configuration.

The KINZE Planter Monitor Module allows a KINZE Vision user to manage compatible KINZE electronic seed monitoring and variable rate drive systems.

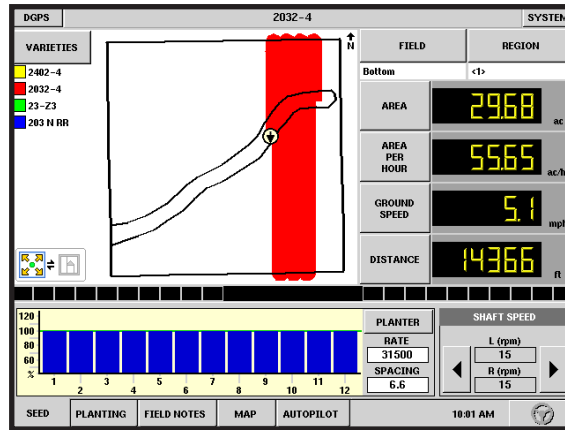

Run Screen With KINZE Population Monitor

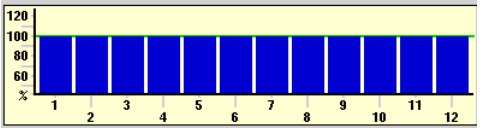
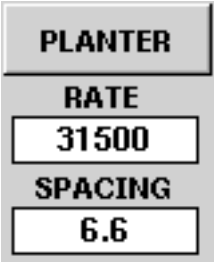
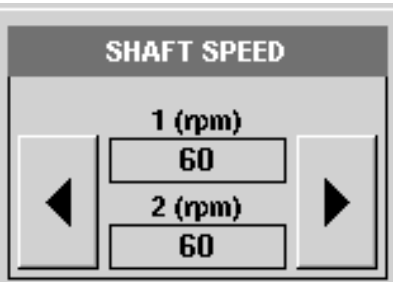
Run Screen Item	Description
	<p>The <b>KINZE Planter Monitor Bargraph</b> consists of a number of bars representing row units. Each bars row height represents that rows population in comparison with the planter average.</p> <p>If a row unit drops below a user-defined threshold, the bar turns red, an audible alarm sounds and an error message appears on the window.</p>
	<p>The <b>Planter</b> button brings up the Planter Monitor Options window, which is discussed further on “<i>KINZE® Planter Monitor Options</i>” on page 6-15.</p> <p>The <b>Rate Display and Spacing Display</b> are where Instantaneous Average Rate and Spacing are displayed either for the entire planter, or for each row, depending upon settings in Planter Monitor Options.</p>
	<p>The <b>Shaft Speed</b> displays the speed of the planter drive shafts, in RPM.</p>

KINZE® PLANTER MONITOR (Continued)

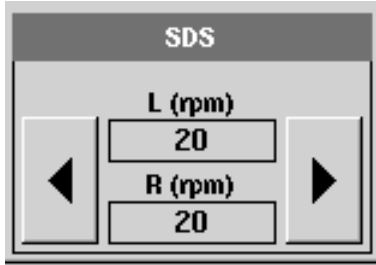
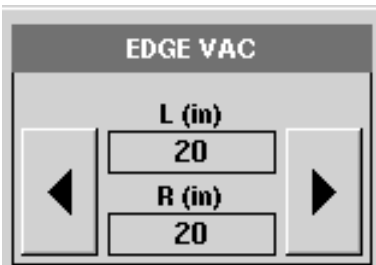
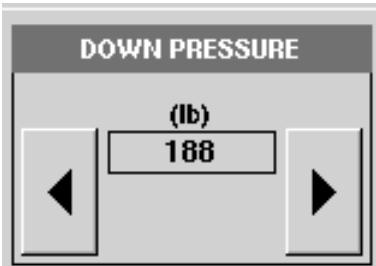

Run Screen Item	Description
	<p>The <b>SDS</b> (Seed Distribution System) displays the speed of the metering auger found in the bulk containers, in RPM.</p>
	<p>The <b>EdgeVac</b>® level is a measurement of seed meter vacuum. This measurement, shown in inches of water, is displayed for each vacuum fan.</p>
	<p>The <b>Pneumatic Down Pressure</b> is a measurement of down force, shown in pounds (kilograms), that the air bag places on the row unit.</p>

## KINZE® PLANTER MONITOR OPTIONS

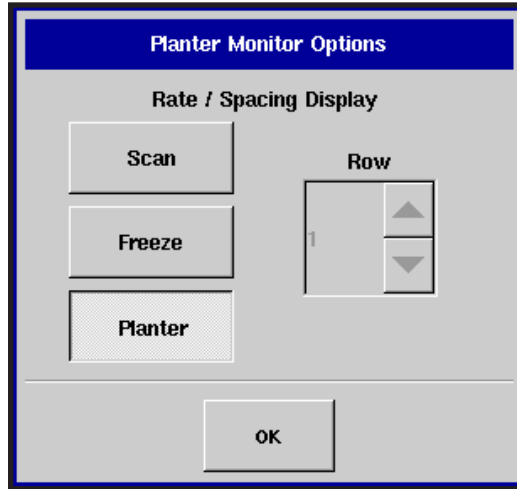
The Planter Monitor Options window, which appears when the operator presses the **Planter** Button on the Run Screen, is where the operator can change settings displayed on the Rate/Spacing Display. Options include Planter Mode, Scan Mode and Freeze Mode, explained below.

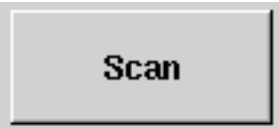

**Planter Monitor Options**



Button	Description
	<p><b>Planter Mode</b> is the default setting for the Rate/Spacing Display. This mode specifies the instantaneous average population and seed spacing for the entire planter.</p>
	<p><b>Scan Mode</b> specifies the Rate/Spacing on a row-by-row scan on all the planter's row units, displayed in sequence from left to right.</p>
	<p><b>Freeze Mode</b> specifies that the Rate/Spacing Display continuously shows only one specified row chosen by the operator.</p>

## KINZE® PLANTER CONTROL

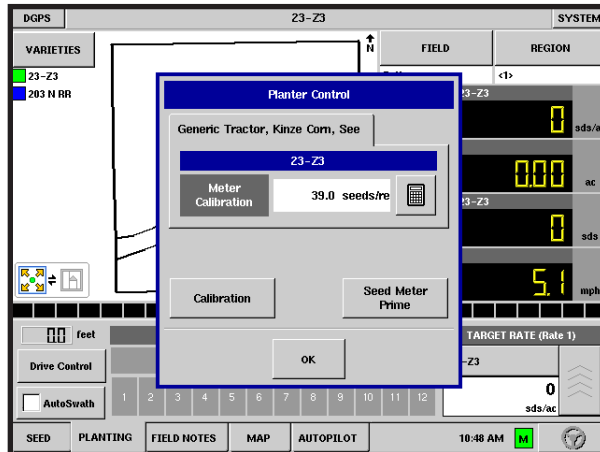
The Planter Control window is where KINZE hydraulic drive users can view or change the seed meter calibration number. To check the Planter Control window, press the **Drive Control** button on the Run screen.



**Planter Control Window**

Item	Description
	<p>The meter calibration setting displays the seed meter calibration number, in seeds per revolution. You may wish to adjust this setting according to the number of seed cells on the seed meter. If so, use the numeric keypad to edit this setting.</p>
	<p>The <b>Calibration</b> button starts the hydraulic drive seed meter calibration procedure. For more information, see “KINZE® Hydraulic Drive Seed Meter Calibration” on page 6-17.</p>
	<p>The <b>Seed Meter Prime</b> button rotates the disk so that the seed meter is properly filled with seed to begin planting. For more information, see “KINZE® Seed Meter Prime (Hydraulic Drive feature)” on page 6-20.</p>

## KINZE® HYDRAULIC DRIVE SEED METER CALIBRATION

**NOTE:** Before calibrating the hydraulic drive, first make any necessary adjustments to the Controller Settings. For more information, see “Controller Settings for KINZE® Hydraulic Drive” on page 5-52 and “Controller Settings - Auxiliary Tab” on page 5-53.

**IMPORTANT:** When the planter is equipped with EdgeVac seed meters, make sure the singulators and vacuum are correctly set before calibrating the hydraulic drive.

KINZE Hydraulic Drive users should calibrate the seed meter at least once a year. To begin, press the **Drive Control** button on the Run screen.

### Press Calibration Button On Planter Control Window

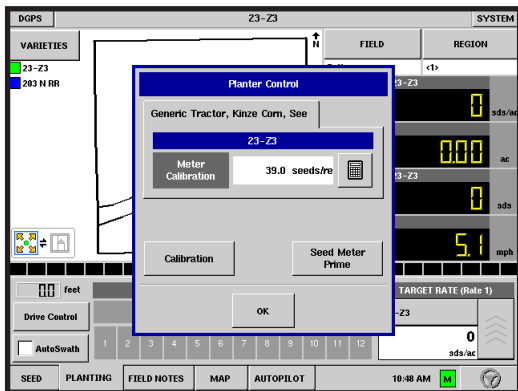

On the Planter Control window, press the Calibration button, and the Meter Calibration Wizard appears.

**NOTE:** Make sure a Meter Calibration Number greater than '0' is entered before starting the calibration procedure.

### STEP 1 Select Drive to Calibrate

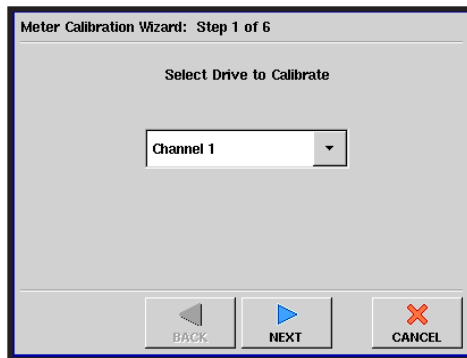

Select the drive you wish to calibrate.

Press **Next** to continue.

### Acknowledge the Warning

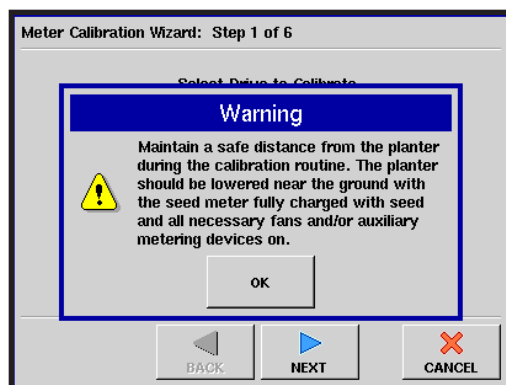

The following warning message will appear. Read it and acknowledge your understanding of it by pressing OK.



**WARNING:** Maintain a safe distance from the planter during the calibration routine. The planter should be lowered near the ground with the seed meter fully charged with seed and all necessary fans and/or auxiliary metering devices on.

Press **Next** to continue.

## KINZE® HYDRAULIC DRIVE SEED METER CALIBRATION (Continued)

### STEP 2 Enter Simulated Ground Speed

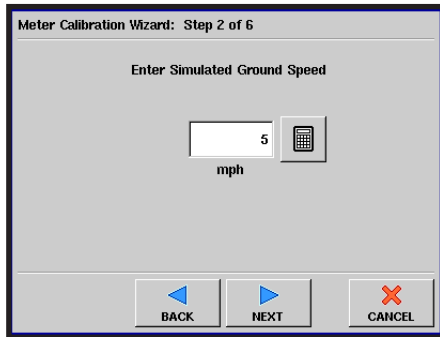

Enter the expected ground speed of your vehicle during the planting operation.

Press **Next** to continue.

### STEP 3 Enter Simulated Target Rate

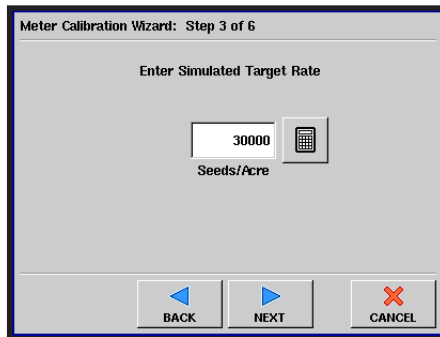

Enter the average target rate of seed distribution during the planting operation.

Press **Next** to continue.

### STEP 4 Press The Start Button



Press **Start**, and the calibration procedure begins.

**NOTE:** Before starting the calibration procedure, make sure that you have seed loaded in the planting box, the vacuum turned on (if appropriate) and a container in place to catch the seed.

## KINZE® HYDRAULIC DRIVE SEED METER CALIBRATION (Continued)

### Wait While Dispensing Seed



Text flashes at the top of the Meter Calibration Wizard window, stating that the seed is dispensing. The drive will stop automatically when calibration is finished.

Also the green button changes to red, indicating that you may stop the calibration procedure if necessary.

### Seed Dispensing Complete

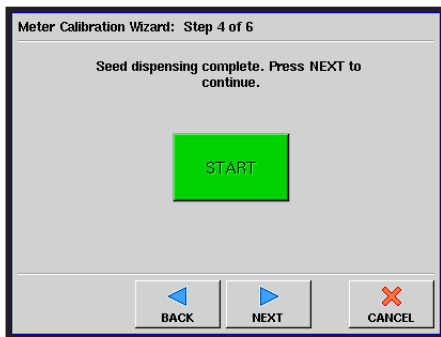

New text appears, informing you that seed dispensing is complete.

Press **Next** to continue.

## STEP 5 Enter Number Of Dispensed Seeds

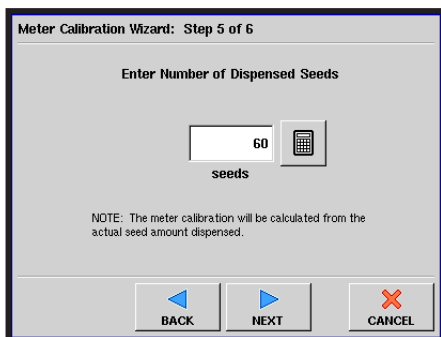

Count the number of seeds that were distributed from one tube, then use the numeric keypad to enter this number.

**NOTE: For more accurate results, you may wish to count the number of seeds distributed by more than one tube, and then enter the average in this window.**

Press **Next** to continue.

## KINZE® HYDRAULIC SEED METER CALIBRATION (Continued)

### STEP 6 Calibration Complete

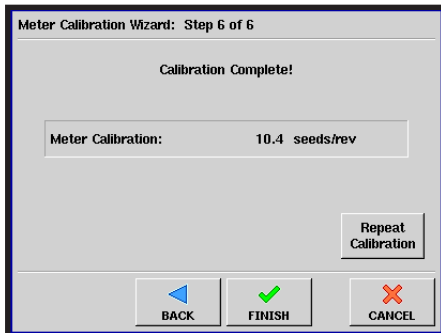

The calibration is complete, and the new meter calibration number appears. From here you may:

- Repeat the calibration, or
- Press **Finish**.

**IMPORTANT:** When the planter is equipped with EdgeVac seed meters, and the number of seeds collected does not match the seeds/rev display, check the singulators and vacuum settings and then recalibrate.

## KINZE® SEED METER PRIME (HYDRAULIC DRIVE FEATURE)

You can use the Seed Meter Prime to populate the seed meter anytime that there are no seeds in it. To begin, press the **Drive Control** button on the Run screen. The Planter Control window appears, as shown below.

### STEP 1 Press Calibration Button On Planter Control Window

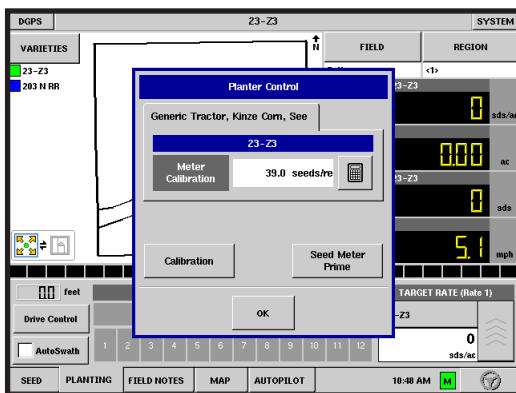

On the Planter Control window, press the **Seed Meter Prime** button.

### STEP 2 Seed Meter Prime In Progress

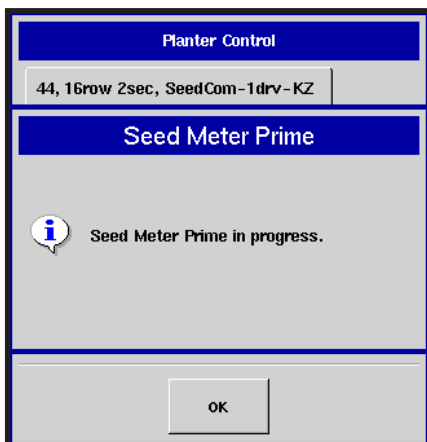

A window appears, informing you that the seed meter prime is in progress. During this time, the seed meter disks will turn one revolution.

Press **OK** to close the Planter Control window and begin planting.

Specific diagnostics information, which pertains to planting functions, can be viewed when you press the Run Screen's **System** button. This diagnostic information includes Clutch Diagnostics (for Clutch Control), Seed Diagnostics (for KINZE Population Monitor), and Input Diagnostics. Technical support may request that you look at this window to help in diagnosing a problem. For generalized diagnostic information, such as memory, display, CAN device and firmware version information, see the General section under “*System Diagnostic Button*” on page 4-61. Information on LED diagnostic states can be found in the Index at “*Module LED Diagnostic States*” on page 7-6.

## Clutch Diagnostics (For Clutch Control)

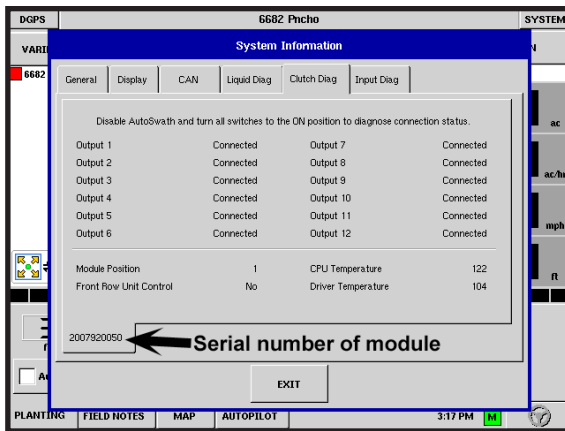

The Clutch Diagnostics Tab shows the voltage flowing from each of the 12 pins in the clutch control module.

For more information about the clutch control module, refer to “*SeedCommand™ Clutch Control Configuration*” on page 5-66.

The bottom left-hand part of this tab shows the serial number of the module.

## Seed Diagnostics (For KINZE® Planter Monitor)

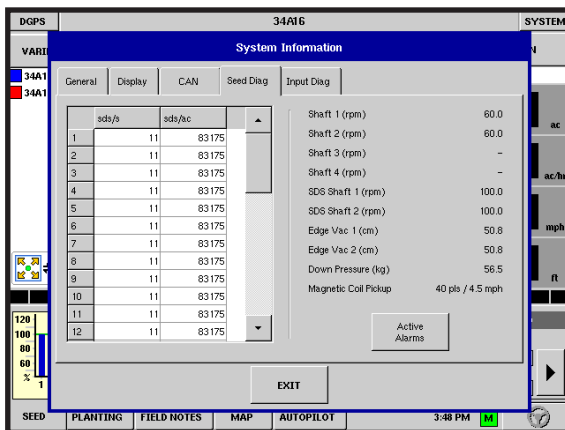

The Seed Diagnostics Tab shows row data from the PMM (Planter Monitor Module), including the following:

- Row unit seeds per second
- Row unit seeds per acre
- **Shaft 1-4** - The speed, in revolutions per minute, sent by the transmission shaft's drive seed meter on the planter.
- **SDS Shaft 1 and 2** - The SDS displays the speed of the metering auger found in the bulk containers, in RPM.
- **EdgeVac 1 and 2** - The EdgeVac® level is a measurement of seed meter vacuum. This measurement, shown in centimeters of water, is displayed for each vacuum fan.
- **Down Pressure** - The pneumatic down pressure is a measurement of down force (shown in kilograms) that the air bag places on the row unit.
- **Magnetic Coil Pickup** - The diagnostic for ground drive transmission of the planter, this signal of which is sent from the Planter Monitor Module (PMM) on the planting unit. Shown in pulses per second and speed of the planter.
- **Active Alarms** - The **Active Alarms** button displays the Active Alarms window, which is described further in “*Alarms on KINZE® Planter Monitor*” on page 6-23.

## SYSTEM DIAGNOSTIC BUTTON (Continued)

### Input Diagnostics

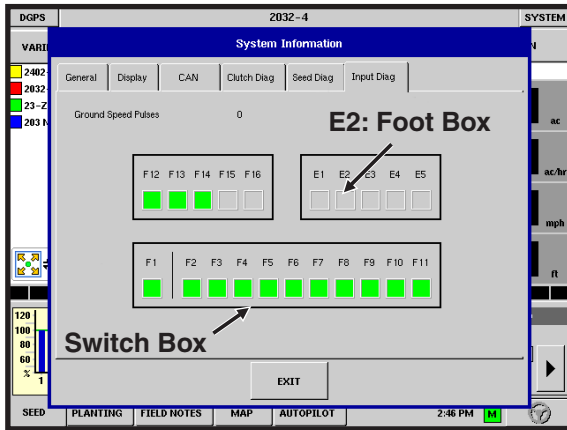

The Input Diagnostic Tab lists the number of Ground Speed Pulses coming in from the radar to the Auxiliary Module.

Additionally, the bottom row of boxes lists the active switches on the switch box. These color-coded boxes display the following diagnostics:

- **Green:** The switch box is connected to the Auxiliary Module in the **On** position.
- **Black:** The switch box is connected to the Auxiliary Module, but is in the **Off** position.
- **Grey:** The switch box is not connected to the Auxiliary Module.

**IMPORTANT:** The E2 position is the indicator for the foot box.

## ALARMS ON KINZE® PLANTER MONITOR

KINZE Planter Monitor users who see the Active Alarms window (as shown below) can use the scroll bar on the right hand side to locate the row units where the alarm is occurring. Acknowledge the alarm by pressing the **Exit** button. After you have dismissed the alarm, you may continue planting, however, the alarm will continue showing in the title bar. You may also review the alarm information underneath the Seed tab of the System Information window, which can be accessed by pressing the **System** button.

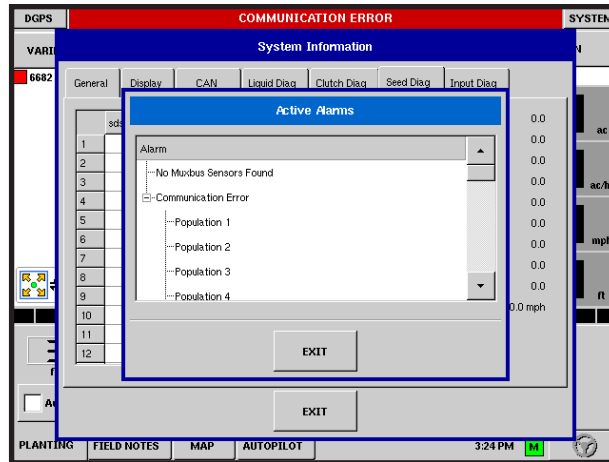

The table below describes various alarms that may occur at system startup. The following pages describe errors that could occur during field operations.

Startup Error Message	Possible Cause	Solution
“Sensors calibrating wait for calibration”	PMM startup	Wait for Planter Monitor Module (PMM) to finish before beginning operation.
“(Row #) sensor not detected”.	Population sensor did not begin communicating with the PMM.	Acknowledge the error by pressing <b>OK</b> . Check the LED on the sensor to see if it is working properly. If it has failed, then replace the sensor. Refer to the KINZE Planter Operator’s manual for further instructions.
“Clean or replace sensor (Row #) as necessary”.	Population sensor dirty.	Press <b>OK</b> to dismiss the error. Then clean the sensor and restart the system.
“(Row #) mux bus data line short to mux bus ground”.	Population sensor’s mux bus signal wire is shorted to ground.	Press <b>OK</b> to dismiss the error. The display then replaces the message window with an alarm text on the header bar at the top of the Run screen. This alarm text continues until the wire is fixed or the sensor is disabled. Inspect the wire at the first opportunity.
“(Row #) mux bus data line short to mux bus power”.	Population sensor’s mux bus signal wire is shorted to power wire.	Press <b>OK</b> to dismiss the error. The display then replaces the message window with an alarm text on the header bar at the top of the Run screen. This alarm text continues until the wire is fixed or the sensor is disabled. Inspect the wire at the first opportunity.

## ALARMS ON KINZE® PLANTER MONITOR (Continued)

Startup Error Message	Possible Cause	Solution
“(Row #) communication lost”.	Seed tube sensor stops communicating with the PMM.	Press <b>OK</b> to dismiss the error. The display then replaces the message window with an alarm text on the header bar at the top of the Run screen. This alarm text continues until the wire is fixed or the sensor is disabled. Inspect the sensor at the first opportunity.
“(Inner or Outer; Right, or Left) Shaft Communication Lost”	Transmission sensor stops communicating with the PMM.	Press <b>OK</b> to dismiss the error. The display then replaces the message window with an alarm text on the header bar at the top of the Run screen. This alarm text continues until the wire is fixed or the sensor is disabled. Inspect the sensor at the first opportunity.
“(Left or Right) EdgeVac sensor communication lost”.	EdgeVac sensor stops communication with the PMM.	Press <b>OK</b> to dismiss the error. The display then replaces the message window with an alarm text on the header bar at the top of the Run screen. This alarm text continues until the wire is fixed or the sensor is disabled. Inspect the sensor at the first opportunity.
“(Left or Right) SDS shaft sensor communication lost”.	SDS shaft sensor stops communicating with the PMM.	Press <b>OK</b> to dismiss the error. The display then replaces the message window with an alarm text on the header bar at the top of the Run screen. This alarm text continues until the wire is fixed or the sensor is disabled. Inspect the sensor at the first opportunity.
“Low hydraulic oil level”.	Hydraulic oil level drops.	Check oil level on the planter, add as necessary.
“High hydraulic oil temperature”	Hydraulic oil temperature level rises.	Stop planter in order to cool down oil temperature. Inspect for cause of overheating.
“Voltage Error Alarm”.	Occurs if the battery voltage drops below 10 volts, or rises above 15 volts.	Check tractor’s electrical system.
“(Row #) Seed Rate Alarm”.	The seed rate of one or more rows is less than the alarm threshold setting and the corresponding transmission shaft sensor detects rotation.	<p>Press <b>OK</b> to dismiss the error. If the alarm state is still present, the graph will state the rows where the errors are occurring, and the Title Bar will flash the type of alarm. Inspect row units to confirm that each has seed, and that all mechanical drive shaft parts are working properly.</p> <p><b>NOTE: If desired, the alarm threshold for the row unit may be set to 0%, which will silence the seed rate alarm. However, the bargraph will continue to operate and the row will still be calculated in the planter average population. For instructions on changing the alarm threshold, see “KINZE® Seed Monitor Alarms” on page 5-47.</b></p>

## KINZE VISION® DISPLAY GENERAL MENU TREE

For more information on these System Navigation buttons, see “System Navigation Buttons” on page 4-6.

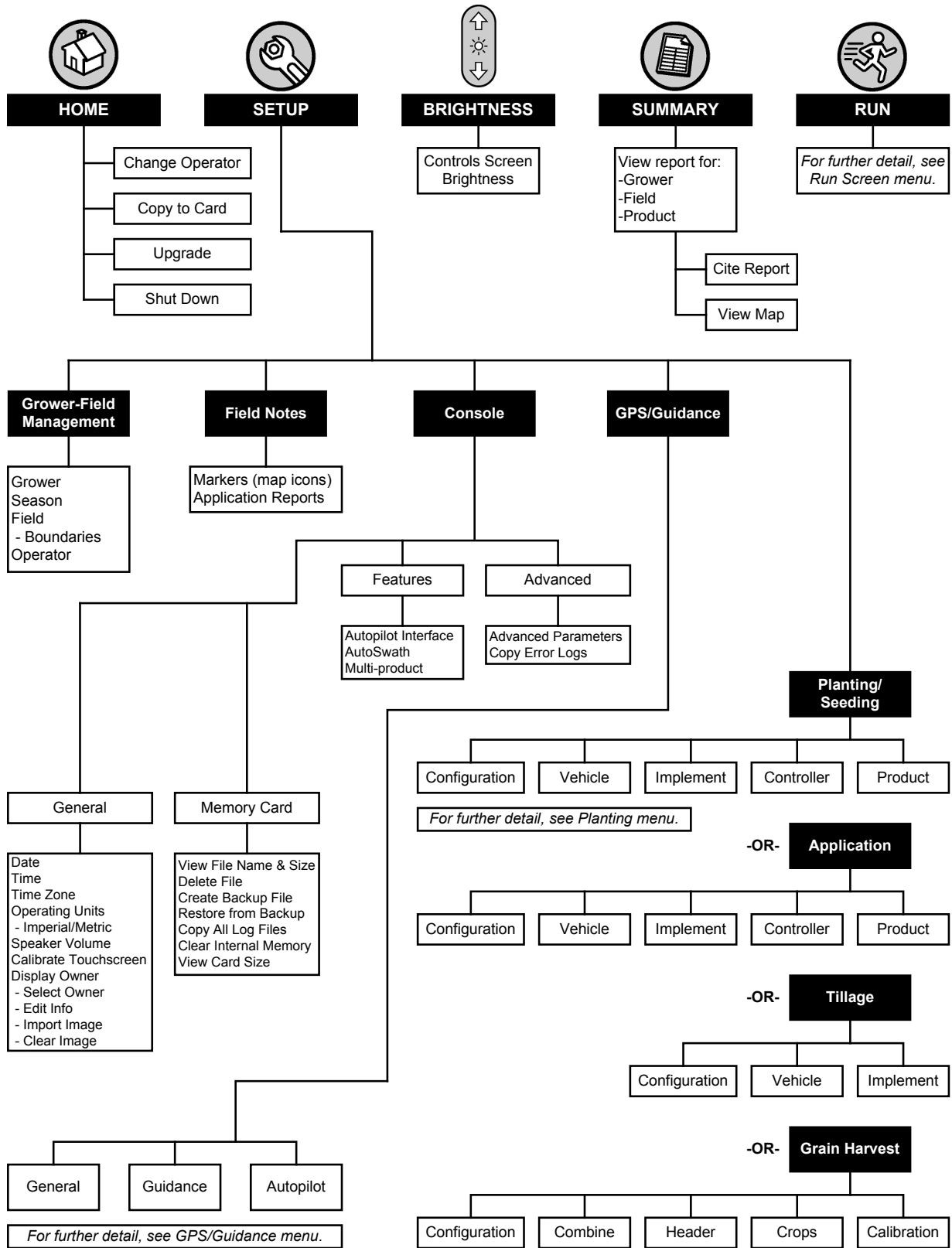

## KINZE® PLANTER MONITOR RUN SCREEN

For more information on the Run Screen command buttons, see “Run Screen Command Buttons” on page 4-7.

For more information on the KINZE Planter Monitor, see “KINZE® Planter Monitor Setup” on page 5-37; for more information on how to configure the KINZE Planter Monitor, see “SeedCommand™ KINZE® Planter Monitor Configuration” on page 5-60.

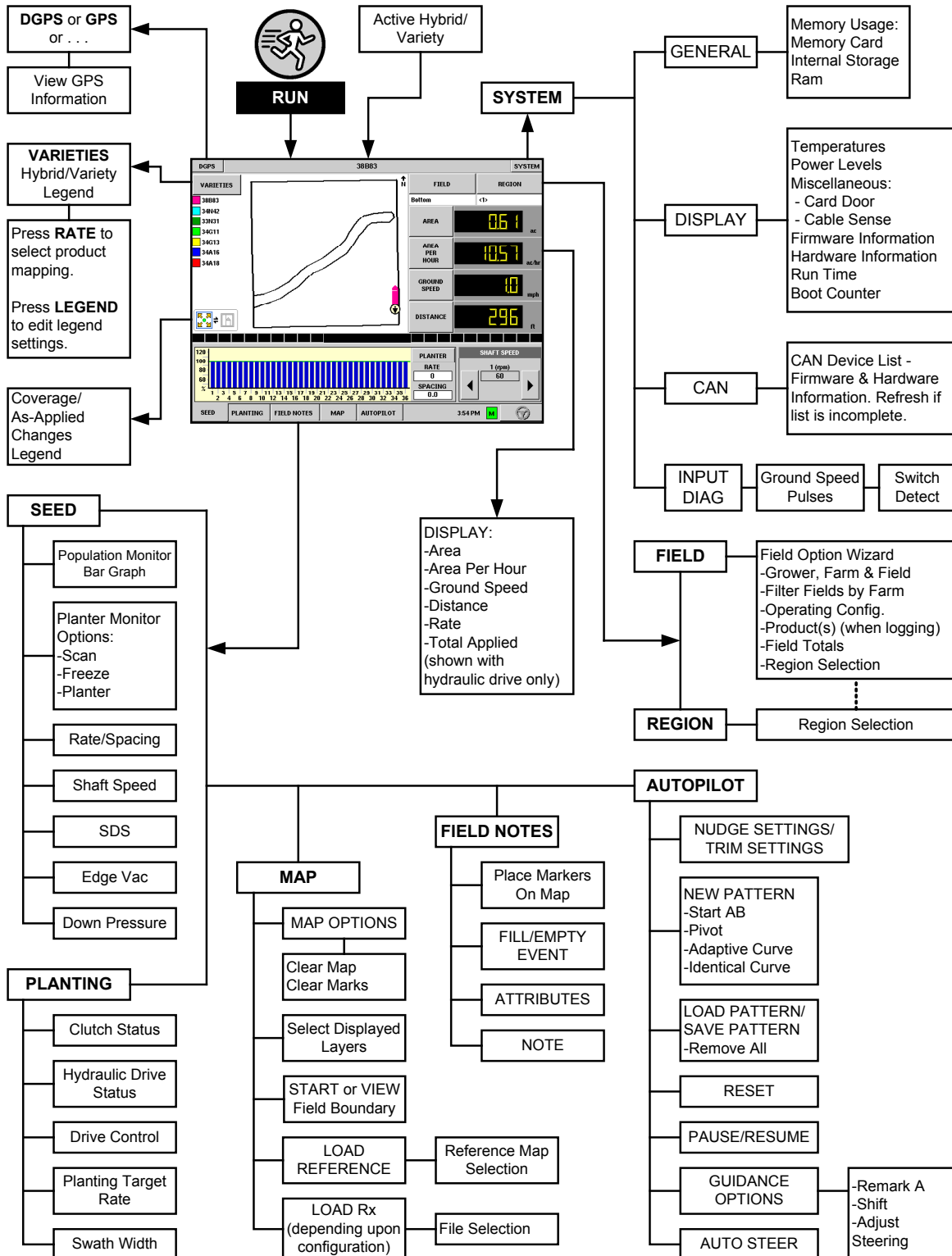

SEEDCOMMAND™ MENU TREE

For more information on SeedCommand configurations, see “SeedCommand™ KINZE® Planter Monitor Configuration” on page 5-60 and also “SeedCommand™ Clutch Control Configuration” on page 5-66.

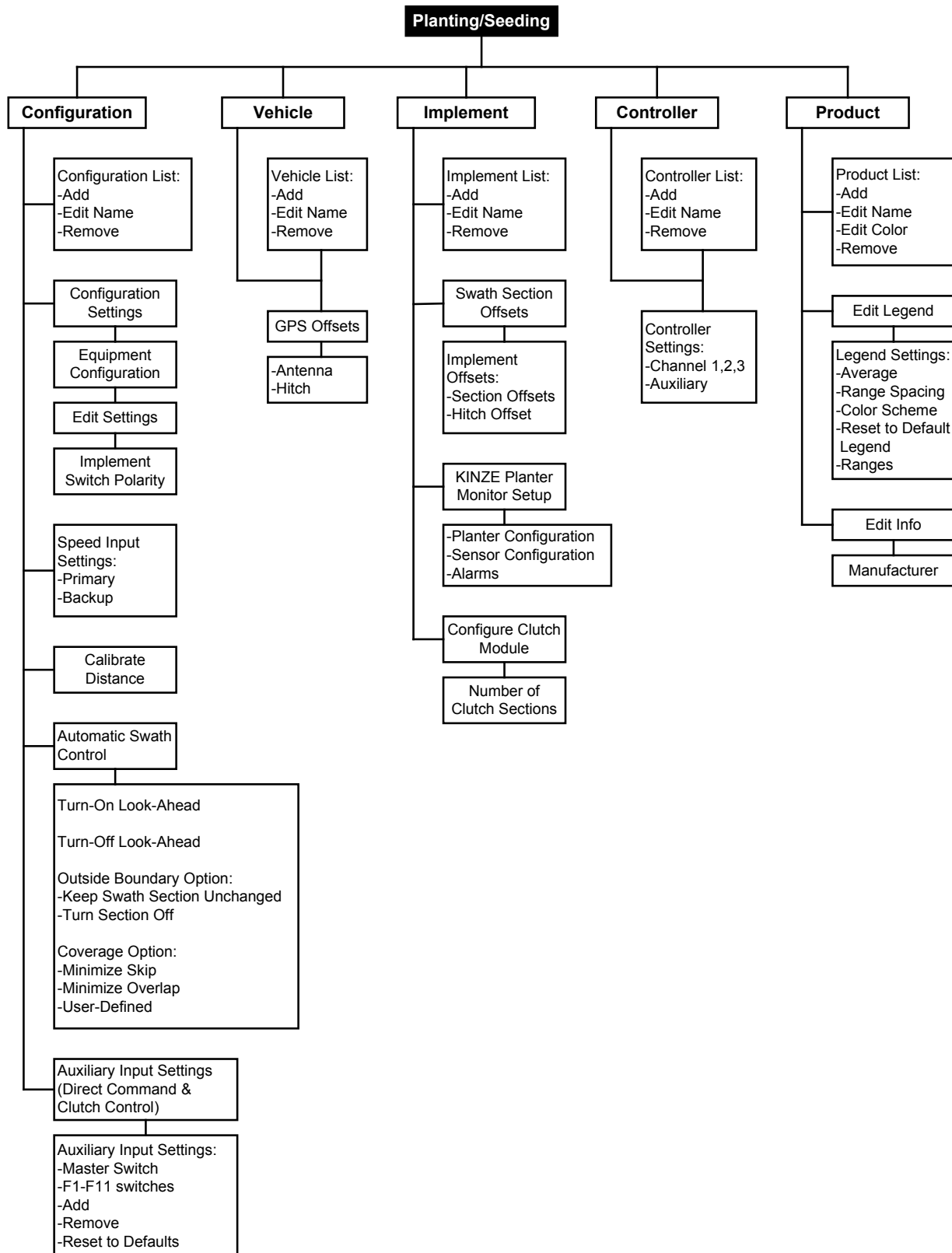

## GPS/GUIDANCE MENU TREE

For more information on GPS/Guidance Setup procedures, see "GPS Setup" on page 4-41.

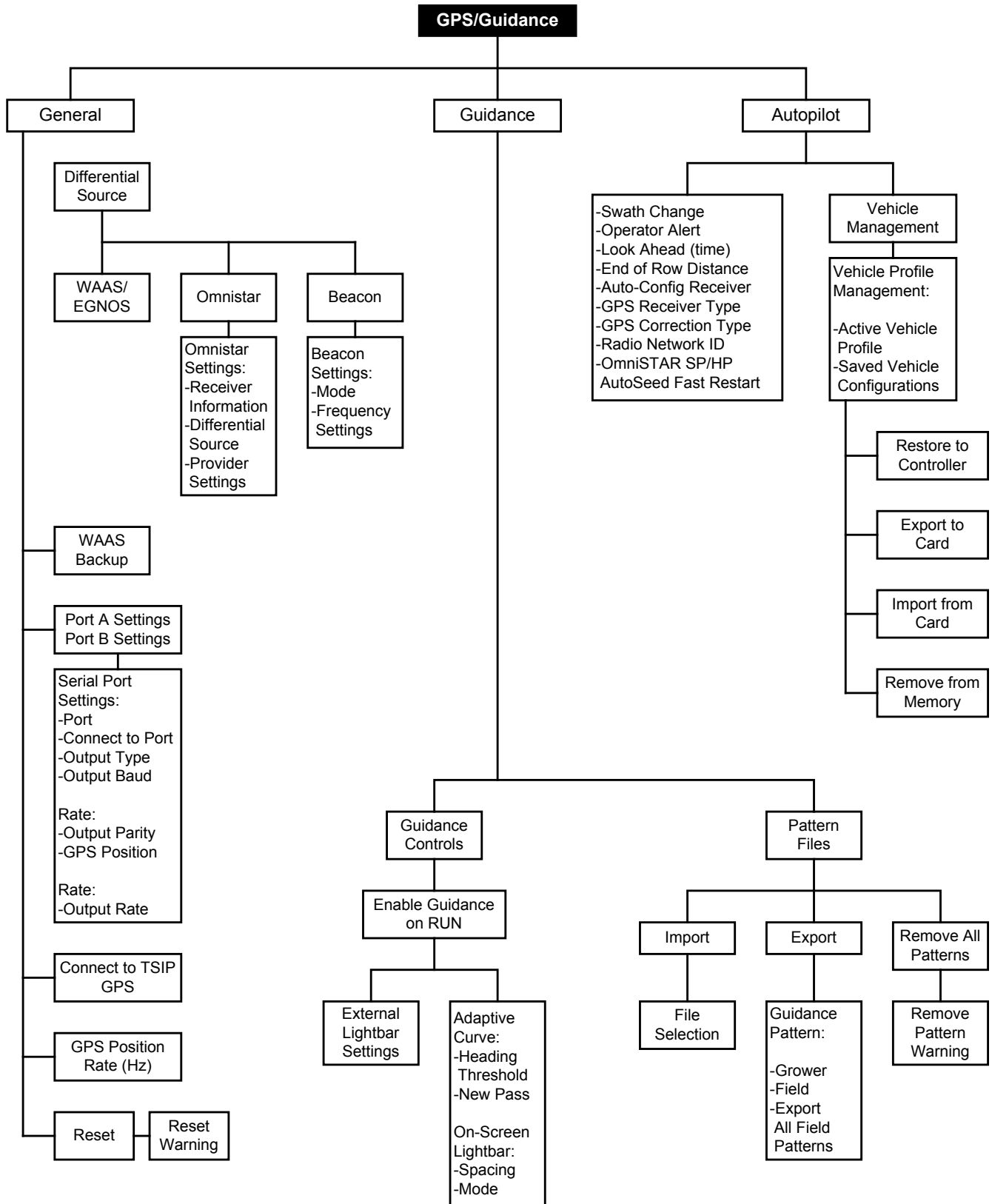

## PRESCRIPTION MAP FILE TYPES

File Extension	Description
.irx	The *.irx file is a new file format designed specifically for use in the KINZE Vision system.
.tgt	This file format is limited to one product recommendation per file. The KINZE Vision system is restricted to single product variable rate application when using this file type.
.shp .shx .dbf	What is commonly called a <b>shape file</b> is actually a collection of three different files. All three of the files are required and must be present on the external storage card for the system to use shape file groups for variable rate product application. A single “shape file” can contain recommendation rates for multiple products.

## BOUNDARY AND GUIDELINE FILE TYPE

File Extension	Description
.iby	KINZE Vision boundary file format. Boundary files are created at the Run Screen or imported to the system from the Setup/Grower-Field Management/Field setup screen.

## IMAGE FILE TYPES

File Extension	Description
.png .bmp	Supported file formats for the Display Owner Image. File size is limited to a maximum of 200 pixels wide by 100 pixels tall. Import the file from the Setup/Console/General setup screen.

## SYSTEM FILE TYPES

File Extension	Description
.ibk	KINZE Vision system backup file. Backup files are written to the external storage card by pressing the <b>Create Backup File</b> button at the Setup/Console/Memory setup screen.
.ilf	KINZE Vision system log file. Created with the <b>Copy to Card</b> button from the Home Screen or pressing the <b>Copy All Log Files</b> button at the Setup/Console/Memory setup screen.
.fw2	Firmware upgrade file for the KINZE Vision display and control modules. Install firmware updates from the external storage card by pressing the <b>Upgrade</b> button on the Home Screen.
.msf	The .msf (Management Setup File) file format allows the KINZE Vision display to import Grower and Field information from SMS software via a Compact Flash Card.

## VEHICLE FILE TYPES

File Extension	Description
.cfg	The .cfg (Configuration) format allows you to import and export Autopilot vehicle profiles. These .cfg files are used by the Autopilot Nav Controller for vehicle parameters and calibration information.

# APPENDIX

# MODULE LED DIAGNOSTIC STATES

LED Display	Condition Represented
Off	No Power
Flashing Green	Normal Operation
Flashing 1 Hz Yellow	CAN Bus Errors Detected (Error Active/Passive State)
Steady Yellow	CAN Bus Off
Steady Red	Hardware Or Initialization Failure
Flashing 1 Hz Red	Firmware Download In Progress
Flashing Fast Red	Firmware Download Error

# KINZIE VISION® PLANTER CONTROL SYSTEM

## QUICK REFERENCE GUIDE

### GENERAL SETUP

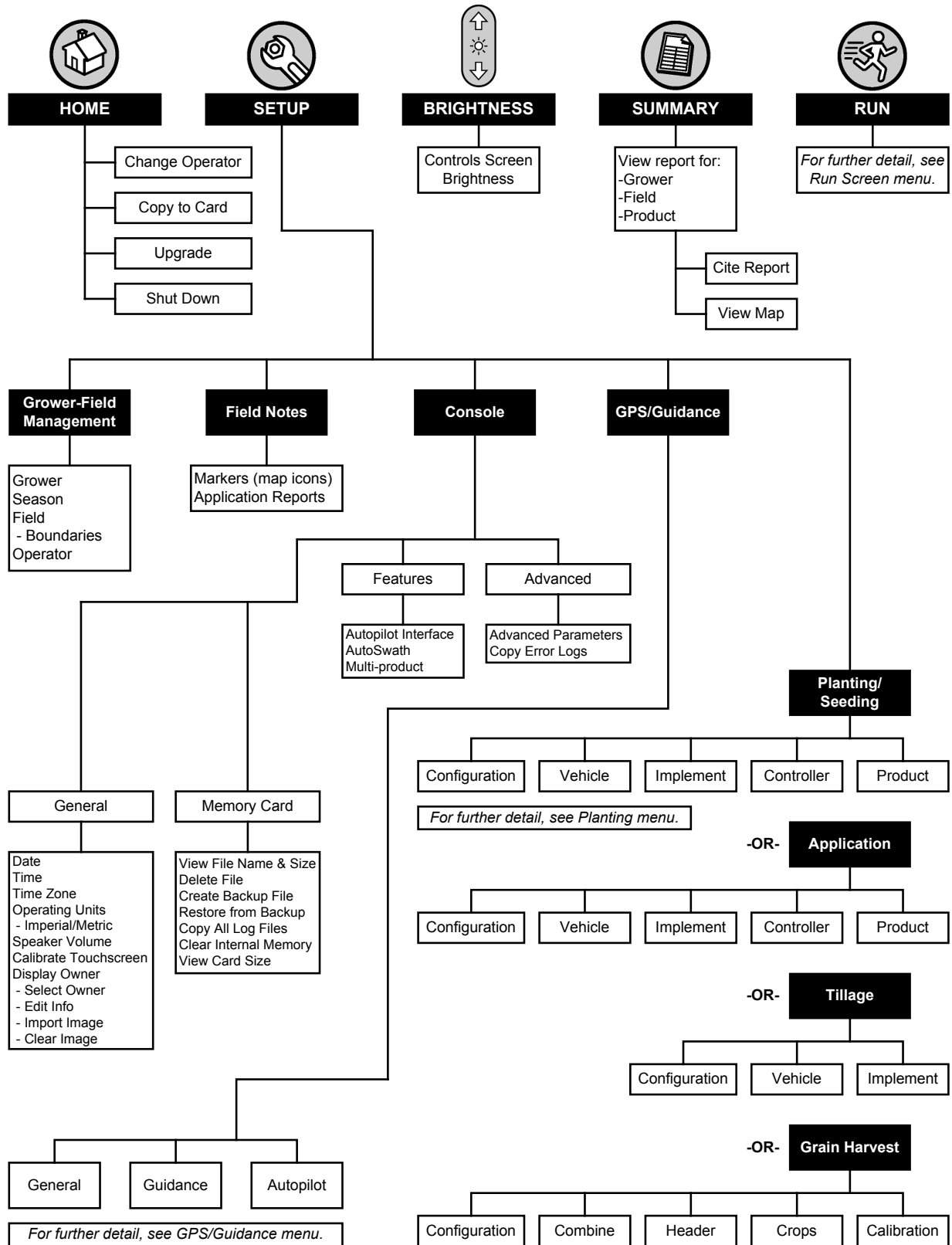

# KINZIE VISION® PLANTER CONTROL SYSTEM

## QUICK REFERENCE GUIDE

### PLANTING CONFIGURATION PROCEDURE

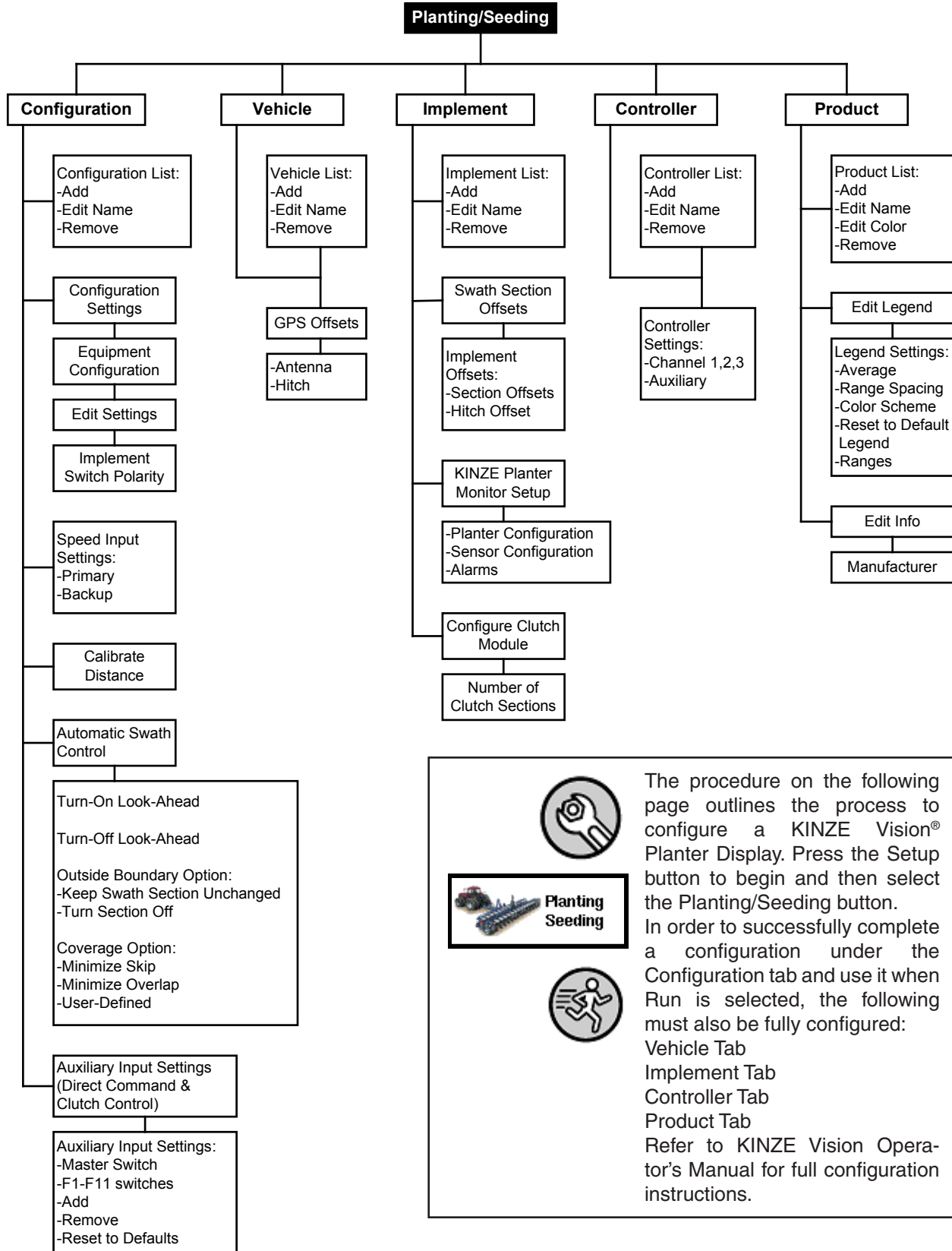

# KINZIE VISION® PLANTER CONTROL SYSTEM

## QUICK REFERENCE GUIDE

---

### STEP 1 Select Vehicle

At the Configuration Tab, press the **Add** button and the Operating Configuration Wizard will appear. Select an existing Implement from the drop down menu, or press the **Add** button and create a new vehicle with the Vehicle Setup Wizard. Press **Next** to continue.

### STEP 2 Select Implement

Select an existing Implement from the drop down menu, or press the **Add** button and create a new implement with the Implement Setup Wizard. Press **Next** to continue.

### STEP 3 Select Planter/Seeder Type

From the top drop down menu, select Planter. Then use the bottom drop-down menu to select either Rear Drawbar or Rear 3-Point Hitch. Press **Next** to continue.

### STEP 4 Select Implement Options

Select the following options, depending upon your desired configuration. (For Interplant planters, you will need to create separate configurations for Interplant and non-Interplant operations).

**NOTE: KINZE® Planter Monitor Module (PMM) - Check this box to enable the KINZE Vision planter monitor functions.**

- **Interplant® Rows Enabled** - Check this box to enable monitoring and logging data from the planter's push row units.
- **Planter Section Clutch Control** - Check this box to enable the planter clutch control.

Press **Next** to continue.

### STEP 5 Enter the Number of Rows and Spacing

Use the up and down arrows to enter the number of rows and spacing, then press **Next**.

### STEP 6 Enter the Number of Implement Sections

Use the up and down arrow to enter the number of implement sections, and press **Next**.

**NOTE: Do not enter the number of individual rows. Enter the number of swath sections that can be independently turned on and off.**

**NOTE: Number of rows on each section should correspond to how the planter is plumbed.**

### STEP 7 Enter Distance from Hitch to Application Point (Front to Back)

Use the numeric keypad to enter the distance from the implement hitch to the application point (from front to back). When finished, press **Next**. Exact dimension is critical.

### STEP 8 Enter Implement Name

Use the keyboard button to enter an Implement Name, then press **Finish**.

### STEP 9 Select Operation Type

Select Rate Logging/Control.

### STEP 10 Select Controller (for Rate Logging and Control)

Select an existing Controller from the drop down menu, or press the **New** button and use the Controller Setup Wizard to create a controller. Use the top drop down menu to select **Seed Command**. Use the bottom drop down menu to select **Hydraulic Seed Control**. Press **Next** to continue.

### STEP 11 Enter Number of Drives

Use the up and down arrows to enter in the number of hydraulic drives on your planter.

### STEP 12 Enter Suggested Controller Name

A suggested controller name appears. If necessary, use the on-screen keyboard to edit the name of the controller.

### STEP 13 Add Additional Application Equipment (optional)

If you plan to use additional application equipment, press the **Add** button and use the Equipment Configuration Wizard to add equipment. Press **Next** to continue.

### STEP 14 Select Ground Speed Source

Select a Primary and Backup Ground Speed Source, (such as GPS, Wheels, Track or Radar). Press **Next** to continue.

### STEP 15 Enter Suggested Name for Configuration

Use the keyboard button to enter a name for the configuration. Press **Finish** when complete

# KINZIE VISION® PLANTER CONTROL SYSTEM QUICK REFERENCE GUIDE

## IMPLEMENT OPTIONS

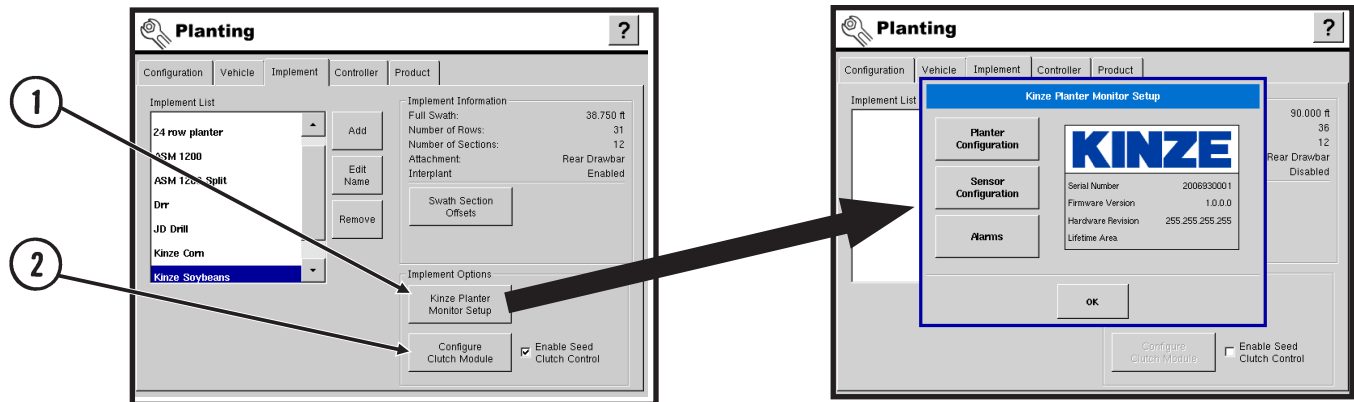

### 1 KINZE® PLANTER MONITOR SETUP



Includes Settings For The Following:

- Number Of Front And Rear Row Units
- Number Of Shaft RPM Sensors
- Minimum Row Spacing (in inches)

Also Includes The Following Setup Tools:

- Magnetic Coil Speed Sensor Calibration Wizard
- Speed Detection Selection (GPS, Auxiliary Or PMM)
- EdgeVac® Calibration (in inches)
- Down Pressure Sensor Selection
- Oil Pressure Sensor Selection
- SDS Sensor Selection

**NOTE: Changing the sensor configuration will open the Sensor Configuration window and initiate the Sensor Learning process. For more information, refer to the KINZE Vision Operator's Manual.**

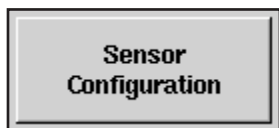

Shows The Status Information For Following:

- Row Unit Sensors
- Shaft RPM Sensors
- Magnetic Pickup Sensors
- SDS Sensors
- Vacuum Sensor
- Down Pressure Sensor
- Oil Pressure Sensor



Opens up the **Seed Monitor Alarms** window, where 10%, 50%, 70%, or a user-defined percentage threshold population alarm is set. The alarm can also be entirely disabled.

### 2 CONFIGURE CLUTCH MODULE

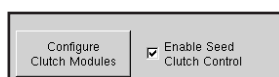

The **Configure Clutch Module** button (which appears when the Enable Seed Clutch Control checkbox is checked) is where the number of clutch sections on the planter is confirmed.

# KINZIE VISION® PLANTER CONTROL SYSTEM

## QUICK REFERENCE GUIDE

### CONTROLLER SETTINGS

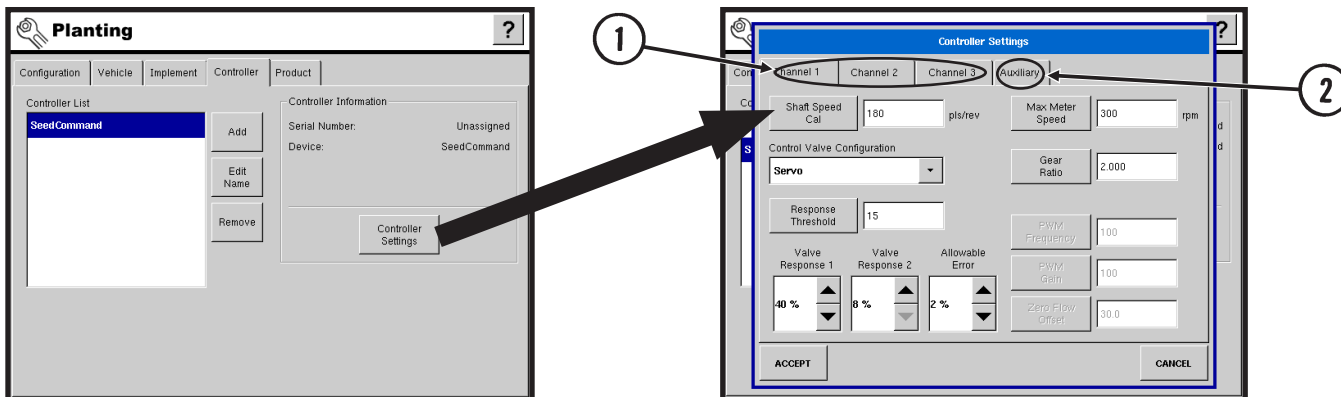

### ① CHANNEL TABS

- Shaft Speed Cal** Calibration number representing the pulses that equal one revolution of the hydraulic motor.
- Control Valve Configuration** Setting determines the type of control valve being used for the hydraulic motor. Choices include Servo or RPM.
- Response Threshold** Determines the system responsiveness to rate change.
- Valve Response 1** Determines the speed of the servo valve when product control error exceeds the Response Threshold setting.
- Valve Response 2** Determines the speed of the servo valve when product control error is less than the Response Threshold setting.
- Allowable Error** Determines the percent of error that is allowed prior to the product control system making any flow rate changes.
- Max Meter Speed** Setting determines the maximum RPM of the seed meter.
- Gear Ratio** Ratio of the revolutions of the hydraulic drive as compared to the revolutions of the seed meter.
- PWM Frequency** The frequency that the PWM control valve is pulsed at. Settings can be found from the manufacturer of the valve. Typical settings range from 180–220 Hz.
- PWM Gain** Determines how aggressively the control valve responds when making rate change adjustments. The higher the value the more aggressive the system response is.
- Zero Flow Offset** Represents the maximum duty cycle that is sent to the control valve without producing any hydraulic flow from the PWM valve. Using too high of a Zero Flow Offset value can cause the product control system to not properly control low rates. See the PWM valve manufacturer’s information for recommended settings.

### ② AUXILIARY TAB

- Min Ground Speed** The Minimum Ground Speed performs two functions: It determines the speed at which the motion detection sensor disengages; and also determines the minimum seed mete RPM when the motion detection sensor is active.
- Rate Threshold** The percentage of seed rate error that triggers the alarms.
- Rate Not Responding Time** The amount of time that the error occurs before the alarm sounds.

# KINZIE VISION® PLANTER CONTROL SYSTEM

## QUICK REFERENCE GUIDE

### RUN SCREEN

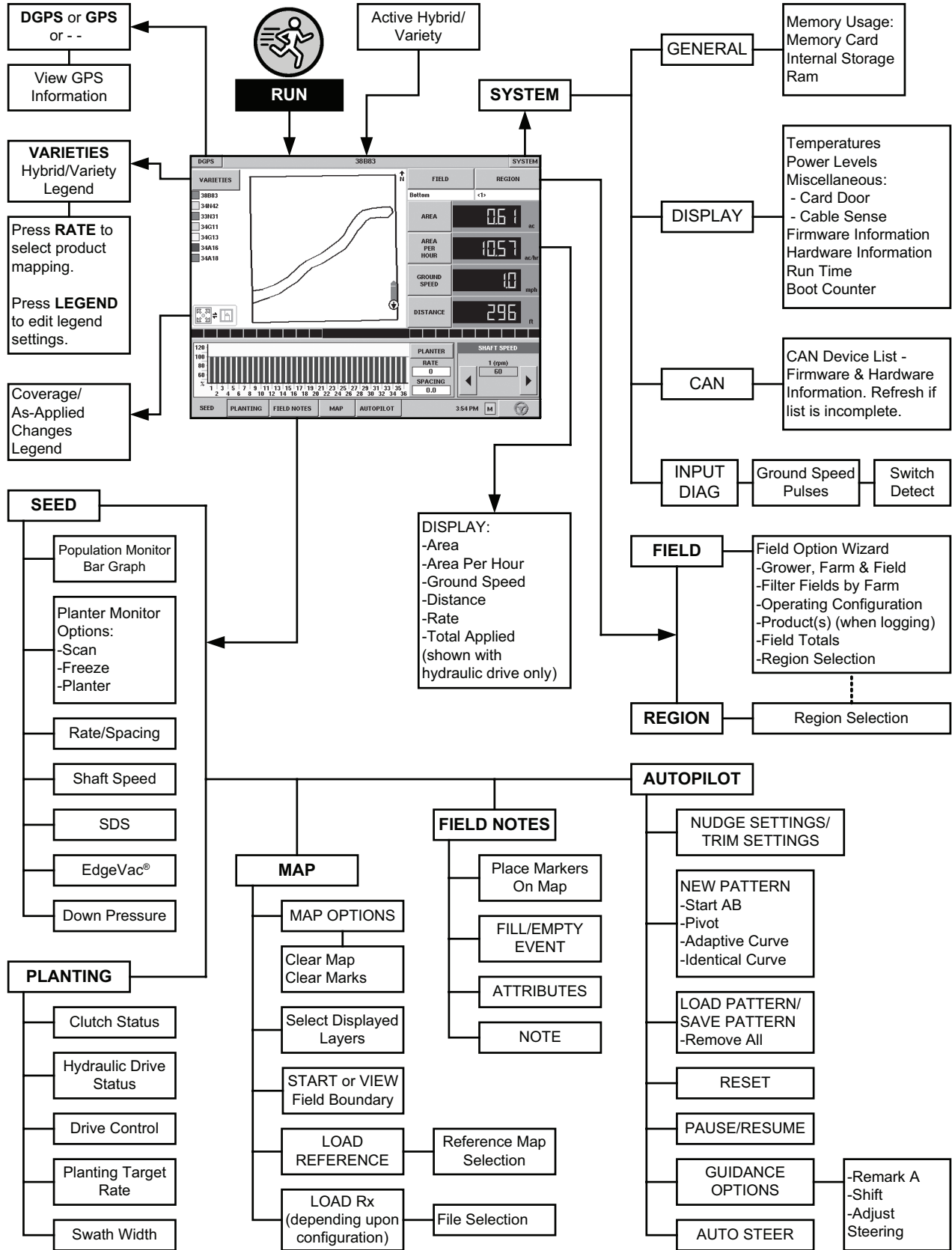

# KINZIE VISION® PLANTER CONTROL SYSTEM

## QUICK REFERENCE GUIDE

### FUNCTIONALITY AND DISPLAY ITEMS

#### KINZE® Population Monitor Bargraph

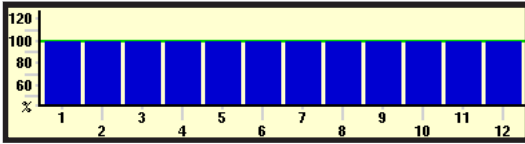

The KINZE Population Monitor Bargraph consists of a number of bars representing row units. Each bar's row height represents that row's population in comparison with the planter average.

If a row drops below a user-defined threshold, the bar turns red, an audible alarm sounds and an error message appears on the window.

#### Planter Button And Displays

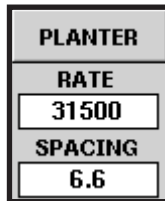

The Planter Button brings up the Planter Monitor Options window.

The Rate Display and Spacing Display are where Instantaneous Average Rate and Spacing are displayed either for the entire planter, or for each row, depending upon settings in Planter Monitor Options.

#### Shaft Speed Display

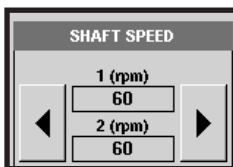

The Shaft Speed displays the speed of the planter drive shafts, in RPM.

#### SDS Display

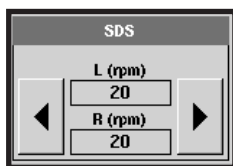

The SDS displays the speed of the metering auger found in the bulk containers, in RPM.

#### EdgeVac® Display

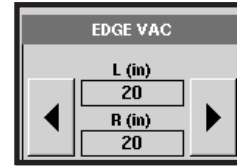

The EdgeVac level is a measurement of seed meter vacuum. This measurement, shown in inches of water, is displayed for each vacuum fan.

#### Pneumatic Down Pressure Display

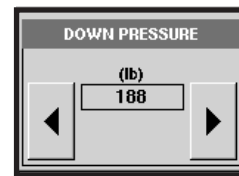

The Pneumatic Down Pressure is a measurement of down force the air bag places on the row unit.

#### Clutch Status Display

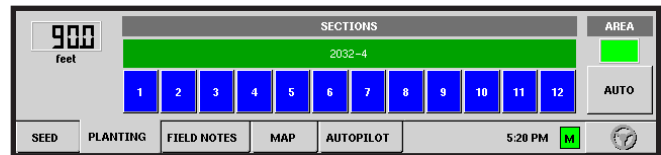

The Clutch Status is displayed for all clutch sections on the Run Screen's Planting Tab.

#### Hydraulic Drive Display

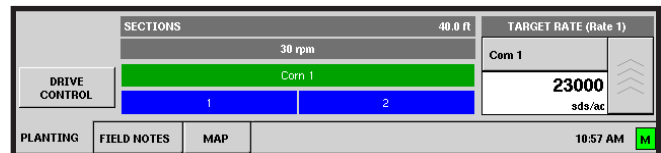

The Hydraulic Drive status is displayed on the bottom left-hand side of the Run Screen's Planting tab population.

The Drive Control button summons the Planter Control window, where you can enter a meter calibration number, perform a seed meter calibration, or use the Seed Meter Prime.

On configurations where the Hydraulic Drive is active, the Planting Target Rate population is displayed at the bottom right-hand side of the Run Screen's Planting Tab. This rate display is similar in appearance to the Application Target Rate display shown for some Application functions.

# KINZIE VISION® PLANTER CONTROL SYSTEM QUICK REFERENCE GUIDE

## WIRING DIAGRAM

